



March 18, 2013  
Via Web Filing

Ms. Patricia Van Gerpen, Executive Director  
South Dakota Public Utilities Commission  
500 East Capitol Avenue  
Capitol Building, 1st Floor  
Pierre, SD 57501

RE: Budget PrePay, Inc. d/b/a Budget Phone  
**Docket TC12-117**

Dear Mr. Van Gerpen:

Enclosed for filing please find the original of the above referenced filing submitted on behalf of Budget PrePay, Inc. d/b/a Budget Phone. The purpose of this filing is to respond to a data request and is based upon the above mentioned docket number and discussions with David Jacobson.

1. Please define "CTP per minute" as found on page 64 of Budget PrePay's FCC tariff and confirm that this is the same service as "Tandem Switching" on page 59 of the South Dakota Intrastate access tariff.

Response: CTP is not the same as Tandem Switching. CTP stands for Common Trunk Port and is part of the circuit between the End Office and the Access Tandem.

2. Why has Budget PrePay not also changed its South Dakota intrastate access mileage based "Tandem Switched per Minute" and "Tandem Switched per Minute per Mile" rates to mirror its FCC rates?

Response: Budget PrePay does not bill any access service therefore they have chosen not to bear the expense of filing the interstate access tariff revisions. If the company decides start to bill switched access services they will file a revised interstate access tariff to mirror the rates.

Please acknowledge receipt of this filing by date-stamping the extra copy of this cover letter and returning it to me in the self-addressed, stamped envelope provided for that purpose.

Any questions you may have regarding this filing should be directed to my attention at 407-740-3001 or via email to [tforte@tminc.com](mailto:tforte@tminc.com). Thank you for your assistance in this matter.

Sincerely,

Thomas M. Forte  
Consultant to Budget PrePay, Inc.

cc: Robin Enkey (Via E-Mail) - Budget  
file: Budget - South Dakota - Access  
tms: SDb1201b

Enclosures  
TF/tf

**(B) TANDEM-SWITCHED TRUNK SERVICES**

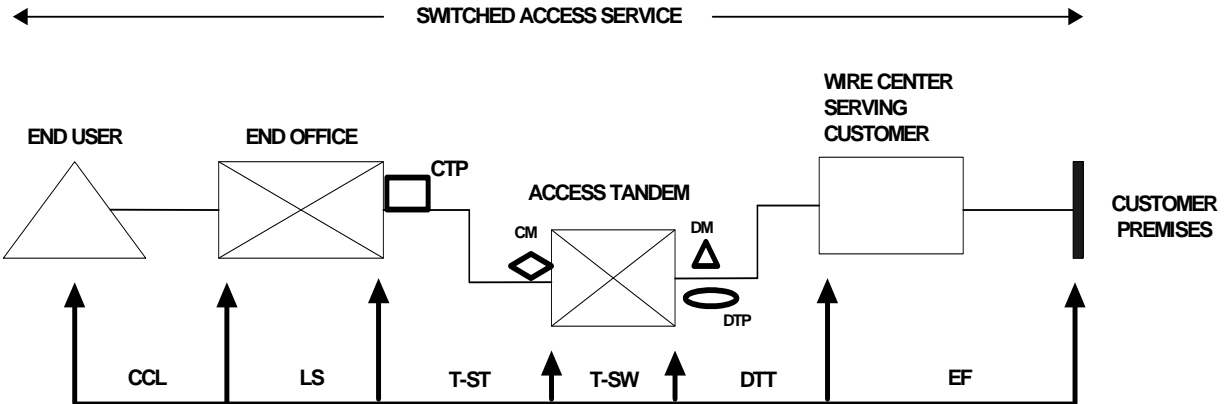

- CCL: CARRIER COMMON LINE
- LS: LOCAL SWITCHING
- T-ST: TANDEM-SWITCHED TRANSMISSION (FIXED & PER MILE)
- T-SW: TANDEM SWITCHING
- DTT: DIRECT-TRUNKED TRANSPORT
- EF: ENTRANCE FACILITY
- CTP: COMMON TRUNK PORT
- CM: COMMON TRANSPORT MULTIPLEXING
- DTP: DEDICATED TRUNK PORT
- DM: DEDICATED MULTIPLEXING

**(C) TERMINATING LINE SIDE SERVICES**

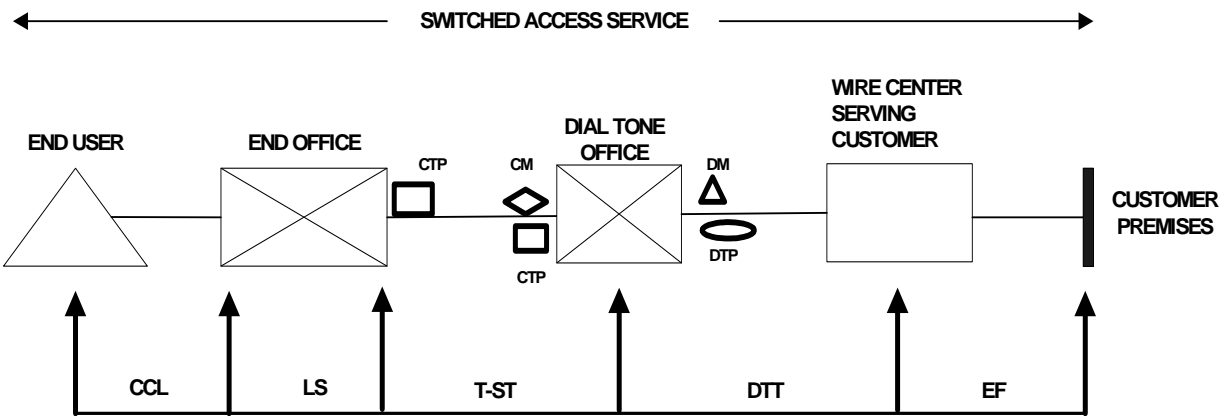

- CCL: CARRIER COMMON LINE
- LS: LOCAL SWITCHING
- T-ST: TANDEM-SWITCHED TRANSMISSION (FIXED & PER MILE)
- DTT: DIRECT-TRUNKED TRANSPORT
- EF: ENTRANCE FACILITY
- CTP: COMMON TRUNK PORT
- CM: COMMON TRANSPORT MULTIPLEXING
- DTP: DEDICATED TRUNK PORT
- DM: DEDICATED MULTIPLEXING