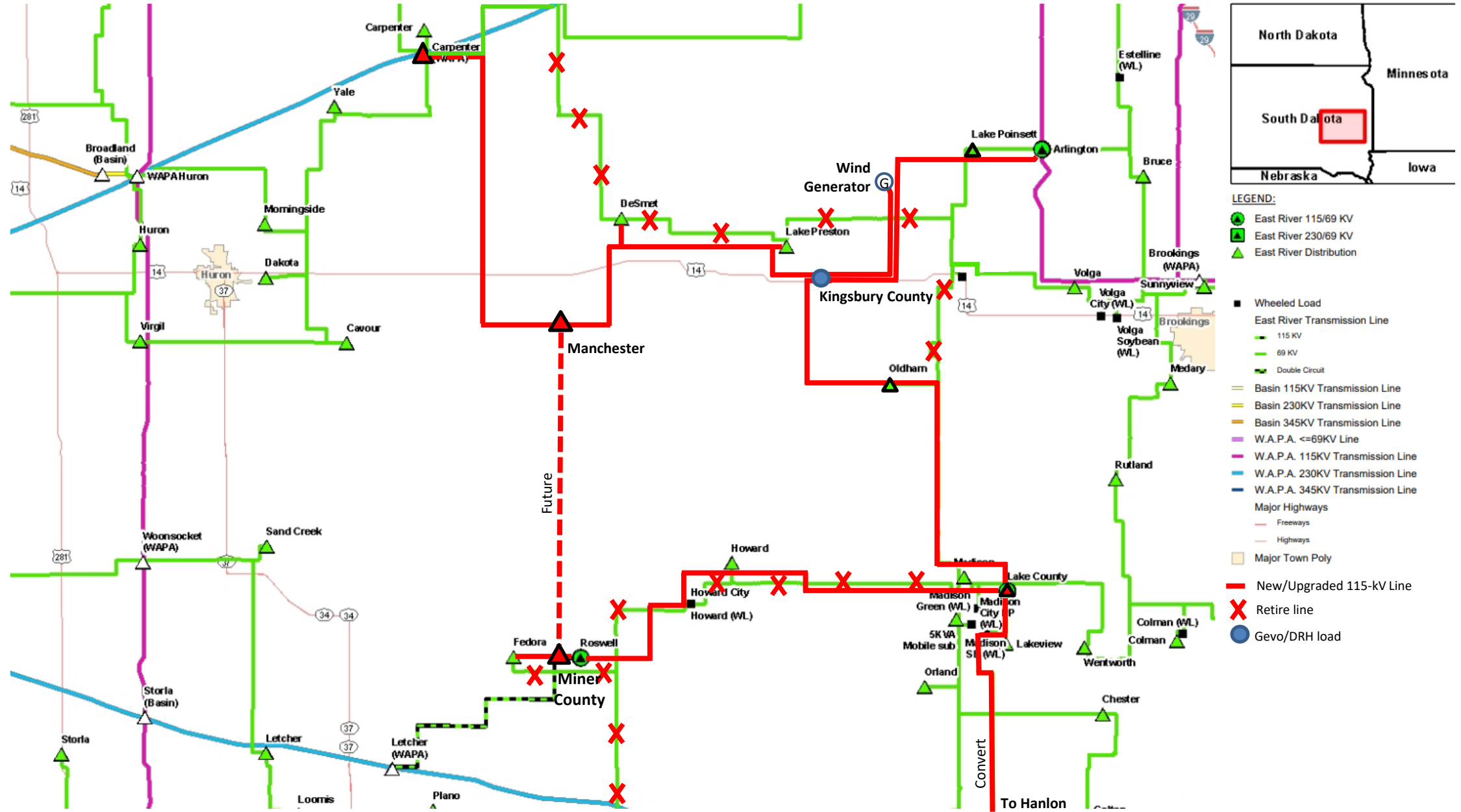
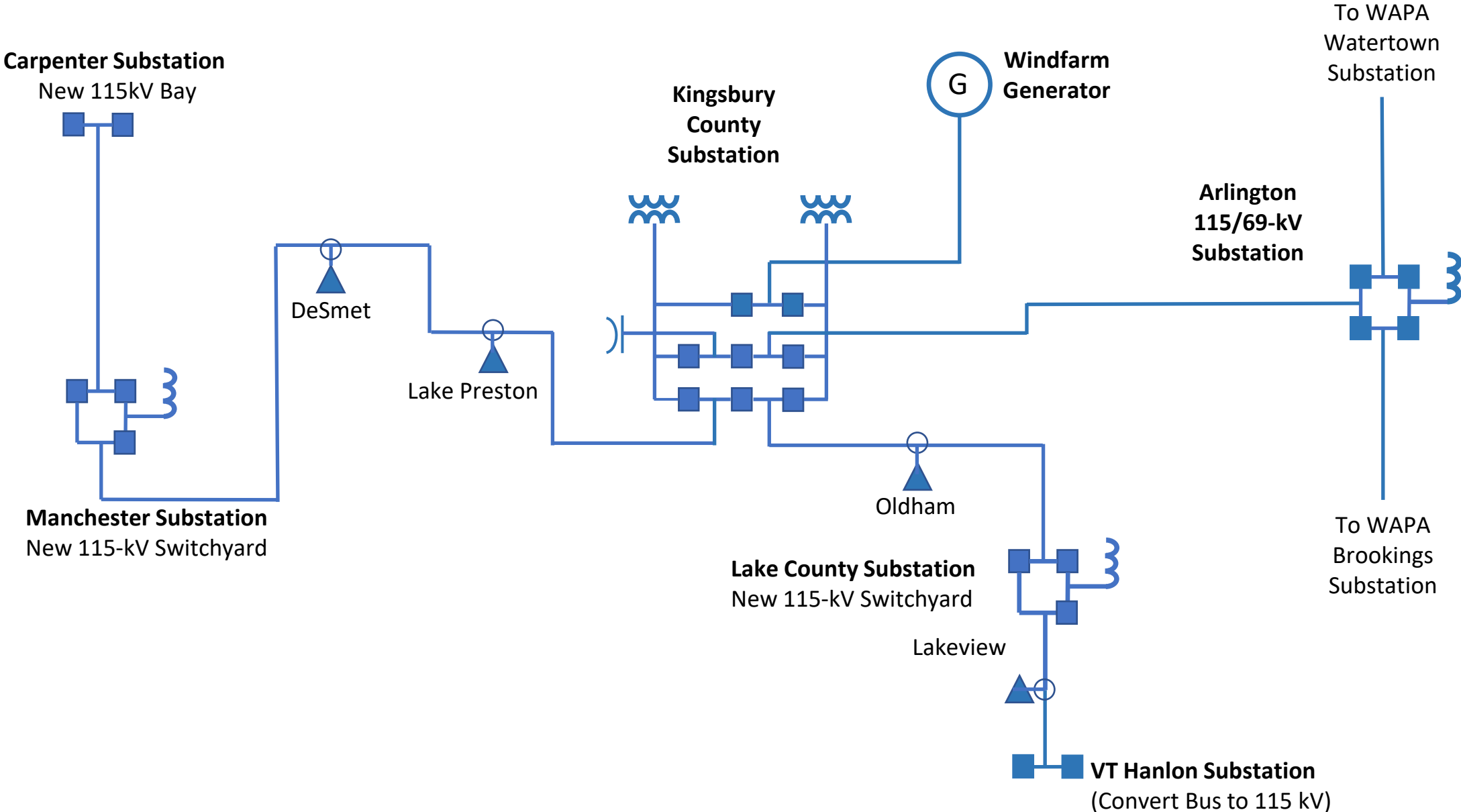

Exhibit 5

East River Transmission Upgrade Plan - Map



East River Transmission Upgrade Plan - Oneline



East River Transmission Upgrade Plan - Proximity to Facilities

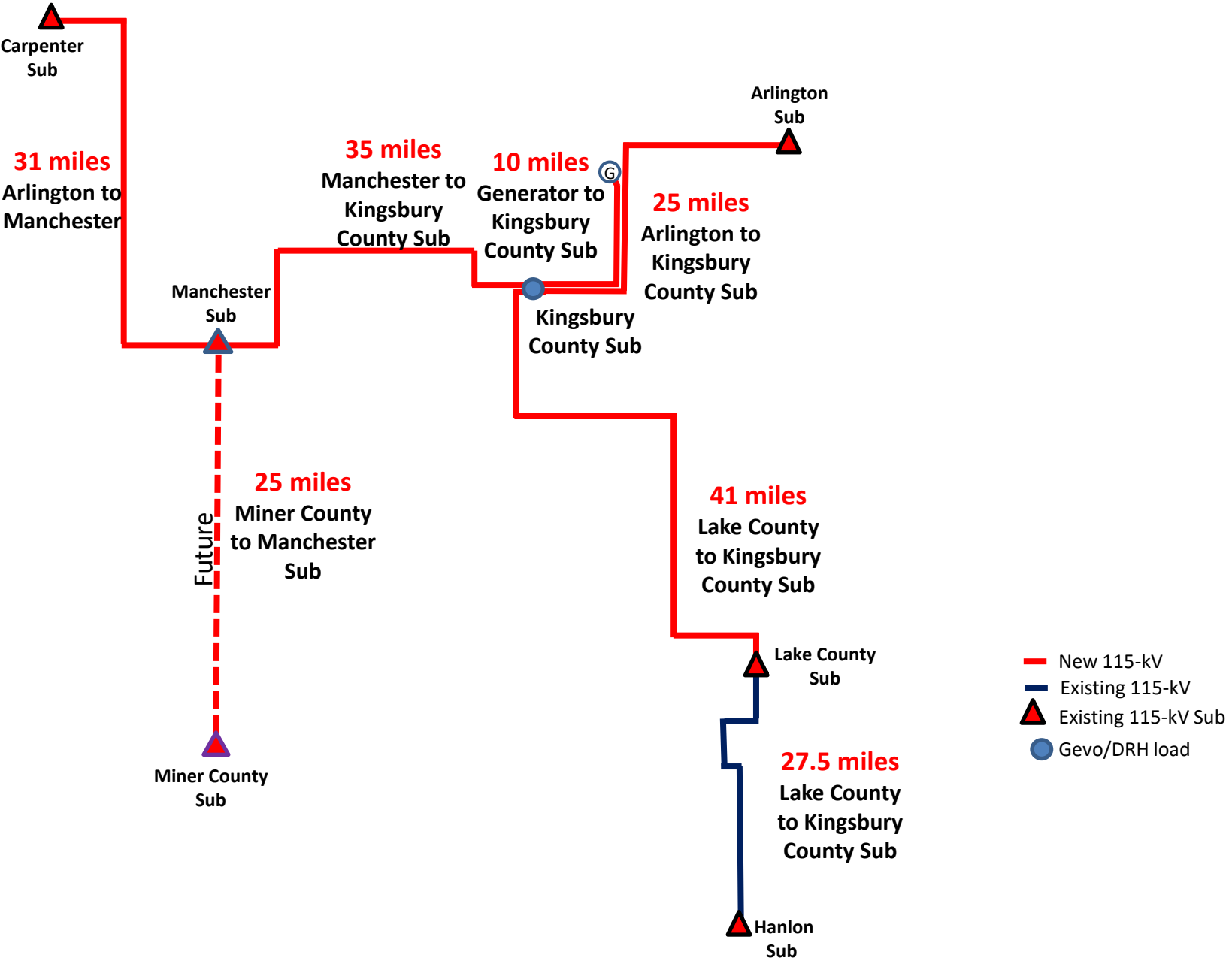

[Trade Secret Begins]

Exhibit

[Trade Secret Ends]