

Esplanade®
Utility Tear Drop LED 2

DECORATIVE
OUTDOOR

HOLOPHANE®
LEADER IN LIGHTING SOLUTIONS
An Acuity Brands Company

2009 ACUITY BRANDS LIGHTING INC., All Rights Reserved

EXAMPLE: ESL2 P10S 40K AS BK TG 3 S

ESL2

ORDERING INFORMATION:

LUMEN / WATTAGE PACKAGE
(SEE PERFORMANCE TABLE FOR DETAILS, Page 2)
P10S = DOWN LIGHT
P10U = DOWN LIGHT AND UP LIGHT
P20S = DOWN LIGHT
P20U = DOWN LIGHT AND UP LIGHT¹
P30S = DOWN LIGHT
P35S = DOWN LIGHT
P40S = DOWN LIGHT
P50S = DOWN LIGHT
P60S = DOWN LIGHT

VOLTAGE
AS = AUTO-SENSING 120 - 277 V
AH = AUTO-SENSING 347 - 480 V

COLOR TEMPERATURE
27K = 2700 CCT
30K = 3000 CCT
40K = 4000 CCT
50K = 5000 CCT

COLOR
BK = BLACK
DB = DARK BLUE
GR = GRAY
GH = GRAPHITE
GN = GREEN
PP = PRIME PAINT
WH = WHITE
BZ = BRONZE
TDC = RAL COLOR (RAL****)
CMC = CUSTOM MATCH COLOR
XX = STD FINISH, TBD

DOOR AND GLASS
TG = TEARDROP² GLASS & DOOR
BG = BOWL GLASS & DOOR
SG = SAG GLASS & DOOR

OPTIC
3 = TYPE 3 ASYMMETRIC
4 = TYPE 4 ASYMMETRIC (ONLY ON TG DOOR AND GLASS)
5 = TYPE 5 SYMMETRIC

TOP ENTRY
P = 1.5 NPT PENDANT MOUNT
S = QUICK LOCK STEM MOUNT

OPTIONS

- AO = ADJUSTABLE OUTPUT DIMMING (NOT AVAILABLE WITH OPTIONS "P5", "P7", OR ANY OTHER DIMMING OPTION)³
- R = NEMA TWISTLOCK PHOTOCONTROL RECEPTACLE (3 PIN)
- P5 = NEMA TWISTLOCK PHOTOCONTROL RECEPTACLE (5 PIN)
- P7 = NEMA TWISTLOCK PHOTOCONTROL RECEPTACLE (7 PIN)
- P3E = PREPARED FOR EXTERNAL 3PIN PHOTOCONTROL RECEPTACLE
- P5E = PREPARED FOR EXTERNAL 5PIN PHOTOCONTROL RECEPTACLE
- P7E = PREPARED FOR EXTERNAL 7PIN PHOTOCONTROL RECEPTACLE
- PSC = SHORTING CAP (MUST BE USED WITH OPTION "R", "P5", OR "P7")
- PCS = DTL TWISTLOCK PHOTOCONTROL FOR SOLID-STATE LIGHTING 120-277V (MUST BE USED WITH OPTION "R", "P5", OR "P7")
- PCLL = DTL LONG LIFE TWISTLOCK PHOTOCONTROL FOR SOLID-STATE LIGHTING 120-277V (MUST BE USED WITH OPTION "R", "P5", OR "P7")
- P34 = DTL TWISTLOCK PHOTOCONTROL 347V (MUST BE USED WITH OPTION "R", "P5" OR "P7")
- P48 = DTL TWISTLOCK PHOTOCONTROL 480V (MUST BE USED WITH OPTION "R", "P5" OR "P7")
- FPDXX = FACTORY PROGRAMMED DRIVER (XX = PERCENTAGE OF LUMENS OR WATTS. SEE PAGE 3)
- DE = ROAM CONCIERGE DIMMING CONTROL (NOT AVAILABLE WITH VOLTAGE CODE AH, OR ANY OTHER PHOTOCONTROL OR DIMMING OPTION)
- PND = 0-10V PART NIGHT DIMMING (AS VOLTAGE ONLY, MUST BE USED WITH OPTION "R")
- DS = 30 INCH DIAMETER DEEP SKIRT FOR CUTOFF REQUIREMENT
- SS = 30 INCH DIAMETER SHALLOW SKIRT FOR CUTOFF REQUIREMENT

OPTIONS (Cont.)

- L1H = 3FT PREWIRED LEADS
- L10 = 10FT PREWIRED LEADS
- L20 = 20FT PREWIRED LEADS
- L25 = 25FT PREWIRED LEADS
- L30 = 30FT PREWIRED LEADS
- NL2X2 = 2"x2" ANSI WATTAGE LABEL
- NL3X3 = 3"x3" ANSI WATTAGE LABEL

ACCESSORIES

- LT3HSS90 = HOUSE SIDE SHIELD, 90 DEGREE (AVAILABLE ON P10S, P10U, P20S, P20U, P30S, AND P35S)
- LT3HSS120 = HOUSE SIDE SHIELD, 120 DEGREE (AVAILABLE ON P10S, P10U, P20S, P20U, P30S, AND P35S)
- LT3HSS180 = HOUSE SIDE SHIELD, 180 DEGREE (AVAILABLE ON P10S, P10U, P20S, P20U, P30S, AND P35S)
- LT5HSS90 = HOUSE SIDE SHIELD, 90 DEGREE (AVAILABLE ON P40S, P50S, AND P60S)
- LT5HSS120 = HOUSE SIDE SHIELD, 120 DEGREE (AVAILABLE ON P40S, P50S, AND P60S)
- LT5HSS180 = HOUSE SIDE SHIELD, 180 DEGREE (AVAILABLE ON P40S, P50S, AND P60S)

NOTES:

1. ONLY AVAILABLE WITH "AS" VOLTAGE
2. ONLY AVAILABLE IN TYPE 3 AND 4
3. FOR AO DATA, REFER TO PAGE 7 OF INSTRUCTION SHEET ON WEBSITE (IM-396)

THIS DRAWING, WHEN APPROVED, SHALL BECOME THE COMPLETE SPECIFICATION FOR THE PRODUCT DESCRIBED. ANY CHANGES TO THE ORDER NOTED ABOVE, A PART OF SIMILAR DESIGN MAY BE SUPPLIED, BUT ONLY AFTER APPROVAL BY THE CUSTOMER IN WRITING. ON POLE ORDERS AN ANCHOR BOLT TEMPLATE PRINT WILL BE SUPPLIED. THIS PRINT IS THE PROPERTY OF HOLOPHANE AND IS LOANED SUBJECT TO RETURN UPON DEMAND AND UPON EXPRESS CONDITION THAT IT WILL NOT BE USED DIRECTLY OR INDIRECTLY IN CONNECTION WITH MATERIAL FURNISHED BY HOLOPHANE.

ORDER #:	RAF
TYPE:	10/11/2018
DRAWN:	LUM_ESL2
DATE:	
DWG NO.:	

**Mark Appropriate
Box for Trim Option**

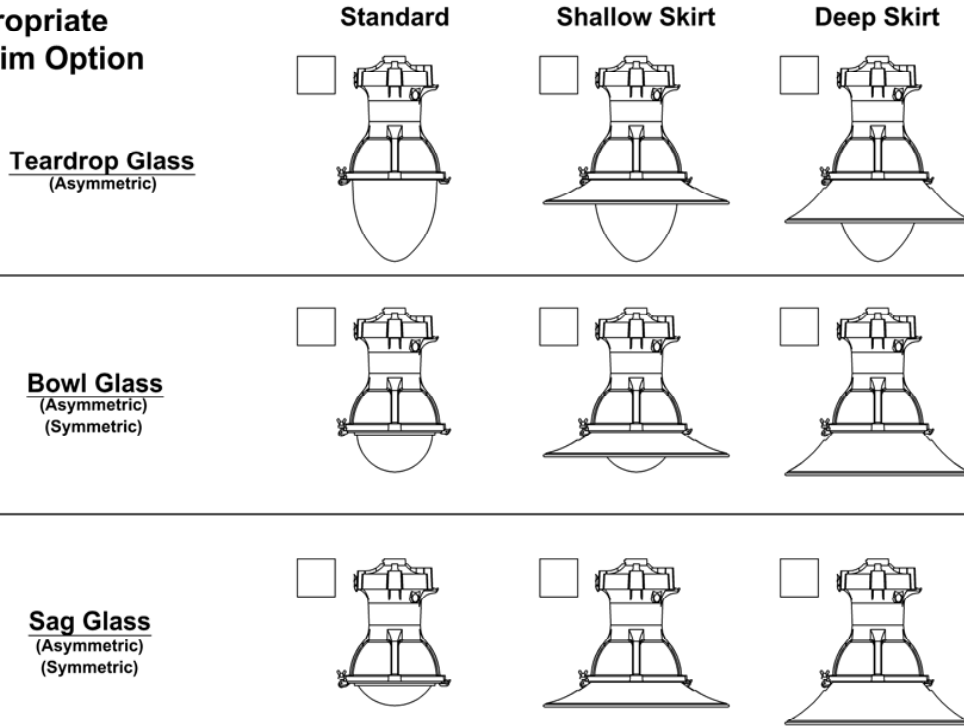

Skirt Dimensions
(For Teardrop, Bowl, and Sag glass)

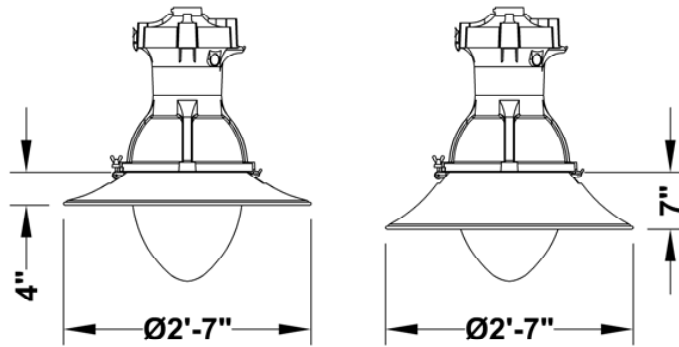

Specifications

DESCRIPTION

The Esplanade luminaire is styled to replicate the “teardrop” luminaires that lighted boulevards in the first half of the 1900s. Designed for light control and ease of installation and maintenance, the Esplanade has a precision optical system for true street lighting performance.

WIRING CHAMBER

The wiring chamber has either a 1.50 inch NPT with a stainless steel set screw or a welded stem. The stem (Quick Lock Stem Mounting option) aids installation speed. A (3) station terminal block that accepts #14 through #2 wires and has a quick disconnect harness with removable electrical module is provided.

ELECTRICAL / REFLECTOR ASSEMBLY

The electrical / reflector assembly hinges down from the wiring chamber for ease in wiring and to facilitate the removal of the electrical module. The assembly is secured in place by a stainless steel latch. The unitized electrical module consists of the electronic driver and components mounted to an aluminum plate that is easily removed by loosening two screws in the base of the housing. The disconnect plug connects the ballast to the terminal block in the wiring chamber.

REFRACTOR / DOOR ASSEMBLY

The cast aluminum door supports a teardrop, bowl or sag shaped, thermal resistant borosilicate glass refractor that controls the light to provide an I.E.S. asymmetric (teardrop, bowl and sag glass) and symmetric (bowl and sag glass) distribution. I.E.S. asymmetric cut off distribution is available on the bowl glass with the decorative deep skirt option and the sag glass with either the decorative shallow or deep skirt option. The refractor assembly and decorative skirt (when applicable) assembly hinges from the electrical / reflector assembly and is latched by a tamper-resistant, color matched bracket and with nut assembly.

DRIVER

LED programmable dimmable driver located in the upper electrical housing.

FINISH / MATERIAL

The luminaire is finished with polyester powder paint to insure maximum durability. All castings utilize low copper aluminum for maximum corrosion resistance and all exposed hardware is stainless steel.

CERTIFICATION

CSA listing suitable for wet location up to 40°C. Consult factory for details.

Esplanade®
Utility Tear Drop LED 2

DECORATIVE
OUTDOOR

HOLOPHANE®
LEADER IN LIGHTING SOLUTIONS
An Acuity Brands Company

THIS DRAWING, WHEN APPROVED, SHALL BECOME THE COMPLETE AND FINAL DESIGN. ANY CHANGES TO THE DESIGN MUST BE NOTED ON THE ORDER NOTED ABOVE. A UNIT OF SIMILAR DESIGN MAY BE SUPPLIED, BUT ONLY AFTER APPROVAL BY THE CUSTOMER IN WRITING. ON POLE ORDERS AN ANCHOR BOLT TEMPLATE PRINT WILL BE PROVIDED. THIS PRINT IS THE PROPERTY OF HOLOPHANE AND IS LOANED SUBJECT TO RETURN UPON DEMAND AND UPON EXPRESS CONDITION THAT IT WILL NOT BE USED DIRECTLY OR INDIRECTLY IN CONNECTION WITH MATERIAL FURNISHED BY HOLOPHANE.

ORDER #:	
TYPE:	RAF
DRAWN:	10/11/2018
DATE:	LUM_ESL2
DWG NO:	

Boston Harbour Series

Cast Aluminum Decorative Arm

Specifications

GENERAL DESCRIPTION

The Boston Harbour decorative crossarm(s) shall be all aluminum construction with a decorative support strap and clamping bracket.

MATERIALS

The crossarm fitter and arm holder(s) shall be heavy wall cast aluminum alloy. The arm(s) shall be of extruded aluminum pipe. The arm(s) shall be circumferentially welded to the arm holder(s). All mounting hardware shall be tamper resistant stainless steel.

DIMENSIONS

The cast fitter is designed to slipfit a 3 inch O.D. by 5 inch tall tenon. The arm gracefully rises approximately 22 inches above the bottom of the fitter and has a span of xx inches from center line of fitter to the end of the arm. Stainless steel set screws are located in the cast fitter for fastening the crossarm to the pole tenon. A clamping bracket is provided to attach the decorative support strap to the pole shaft. For twin crossarms, all symmetrical dimension are the same as on the single.

FINISH

The crossarm shall be furnished with a powder coat finish.

Note: If arm is ordered without a pole, pole shaft details must be supplied before order can be released.

CATALOG #'S:

BHC48/1-CA/XX
BHC72/1-CA/XX
BHC96/1-CA/XX
BHC96/2-CA/XX
BHC144/2-CA/XX
BHC192/2-CA/XX

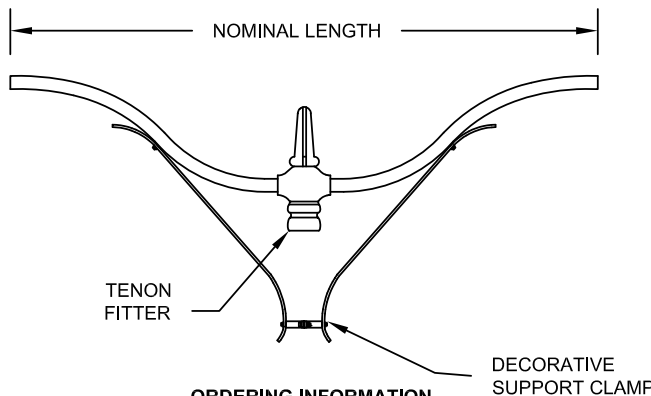
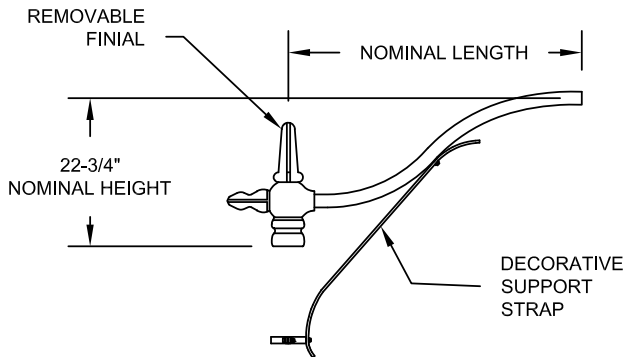

ORDERING INFORMATION

EXAMPLE: BHC 48/1 - CA / BK

BHC

/

-

CA

/

BK

BOSTON HARBOUR STYLE ARM

ARM LENGTH (SINGLE ARM, FROM CENTER TO END OF ARM)
(DOUBLE ARM, FROM END TO END OF ARMS)
48 = 48 INCHES (SINGLE ARM ONLY)
72 = 72 INCHES (SINGLE ARM ONLY)
96 = 96 INCHES (SINGLE & DOUBLE)
144 = 144 INCHES (DOUBLE ARM ONLY)
192 = 192 INCHES (DOUBLE ARM ONLY)

NO. OF ARMS
1 = SINGLE ARM
2 = DOUBLE ARM

MATERIAL
CA = ALUMINUM

FINISH
BK = BLACK
DB = BRONZE
DG = DARK GREEN
CS = CUSTOM SELECT (RAL COLOR)
CM = CUSTOM MATCH (FROM CUSTOMER COLOR SAMPLE)

NOTE:
WHEN USED WITH TOP MOUNT LUMINAIRES, A FITTER NEEDS TO BE ORDERED FOR THE END OF EACH ARM.

ARCHITECTURAL OUTDOOR ORDER #:

TYPE:

DRAWING NO: US-1469

THIS DRAWING, WHEN APPROVED, SHALL BECOME THE COMPLETE SPECIFICATION FOR THE MATERIAL TO BE FURNISHED BY HOLOPHANE ON THE ORDER NOTED ABOVE. A UNIT OF SIMILAR DESIGN MAY BE SUPPLIED, BUT ONLY AFTER APPROVAL BY THE CUSTOMER IN WRITING. ON POLE ORDERS AN ANCHOR BOLT TEMPLATE PRINT WILL BE SUPPLIED WITH EACH ANCHOR BOLT ORDER TO MATCH THE POLE PROVIDED.

THIS PRINT IS THE PROPERTY OF HOLOPHANE AND IS LOANED SUBJECT TO RETURN UPON DEMAND AND UPON EXPRESS CONDITION THAT IT WILL NOT BE USED DIRECTLY OR INDIRECTLY IN ANY WAY DETRIMENTAL TO OUR INTERESTS, AND ONLY IN CONNECTION WITH MATERIAL FURNISHED BY HOLOPHANE.



SCALE: N/A
DRAWN: RAF
APP'D:
DATE: 12/28/09

NOTES:

- 1) Pole Designed To Meet AASHTO 2013 Edition (Excluding Breakaway) For A 90 mph Wind Velocity For The Following Design Conditions:
 - Maximum Luminaire Size: 1.72 ft² EPA & 47 lbs.
 - Maximum Banner Size: 24" x 36"
 - Maximum Decoration Size: 2.0 ft² EPA & 25 lbs
- 2) All Loose Hardware Bagged Individually Per Pole Assembly.
- 3) Pole Shall Be Powder Coated Textured Black per HAPCO Specification 73737-T01.

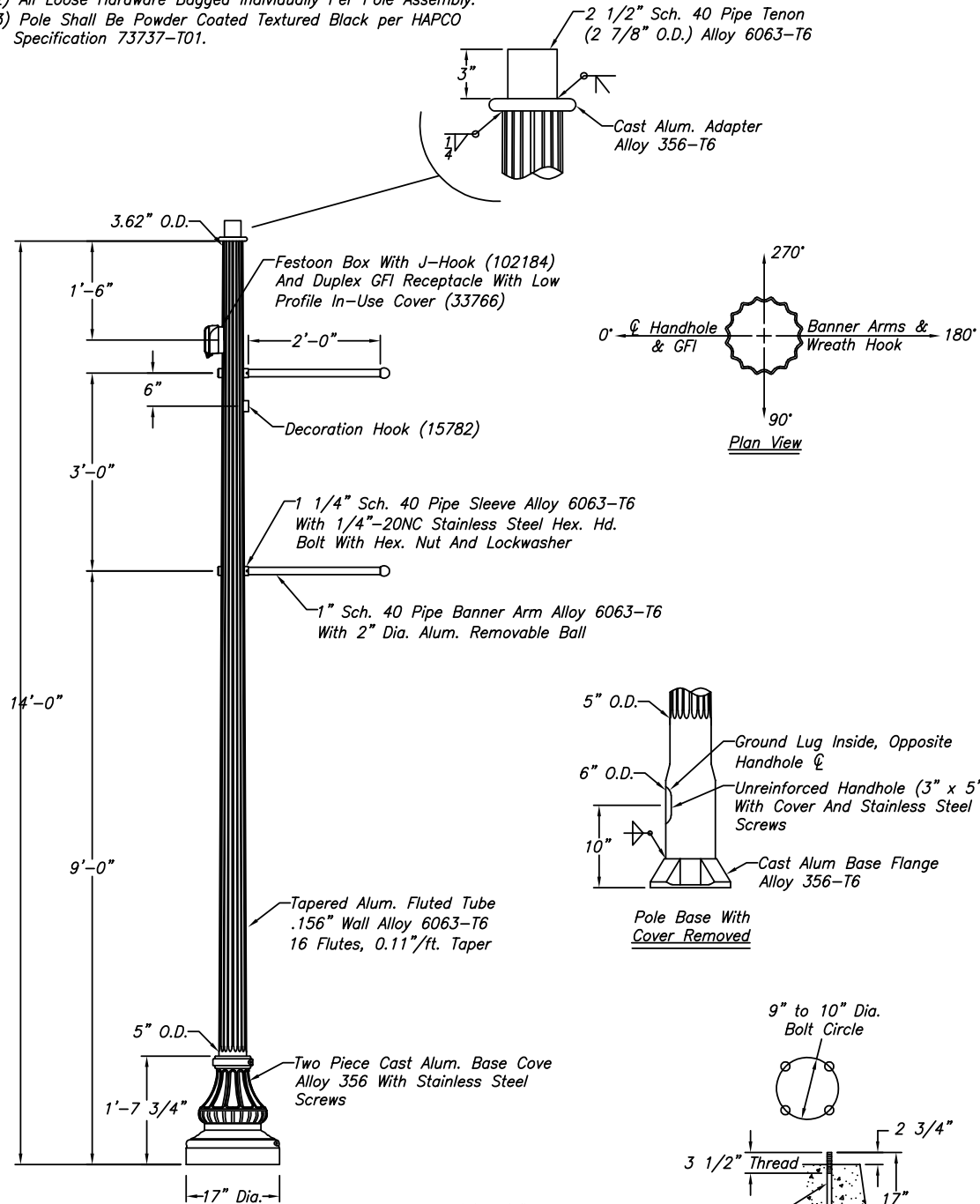

- (4) 3/4"-10NC Galv. Stl. Anchor Bolts, AASHTO M314-90 Grade 55, 10" Of Threaded End Galv. Per ASTM A153.
- (4) 3/4"-10NC Galv. Stl. Hex. Nuts
- (4) 3/4" Galv. Stl. Lockwashers
- (4) 3/4" Galv. Stl. Flatwashers

B104011

WARNING: DO NOT INSTALL LIGHTING POLES WITHOUT LUMINAIRES

NO.	REVISIONS	DATE

hapco
Abingdon, Va.

TITLE ARLEN SERIES LIGHTING POLE
CUSTOMER Otter Tail
SCALE 16 DATE 03/31/2020
BY TNB DWG. NO.
CHK'D B104011

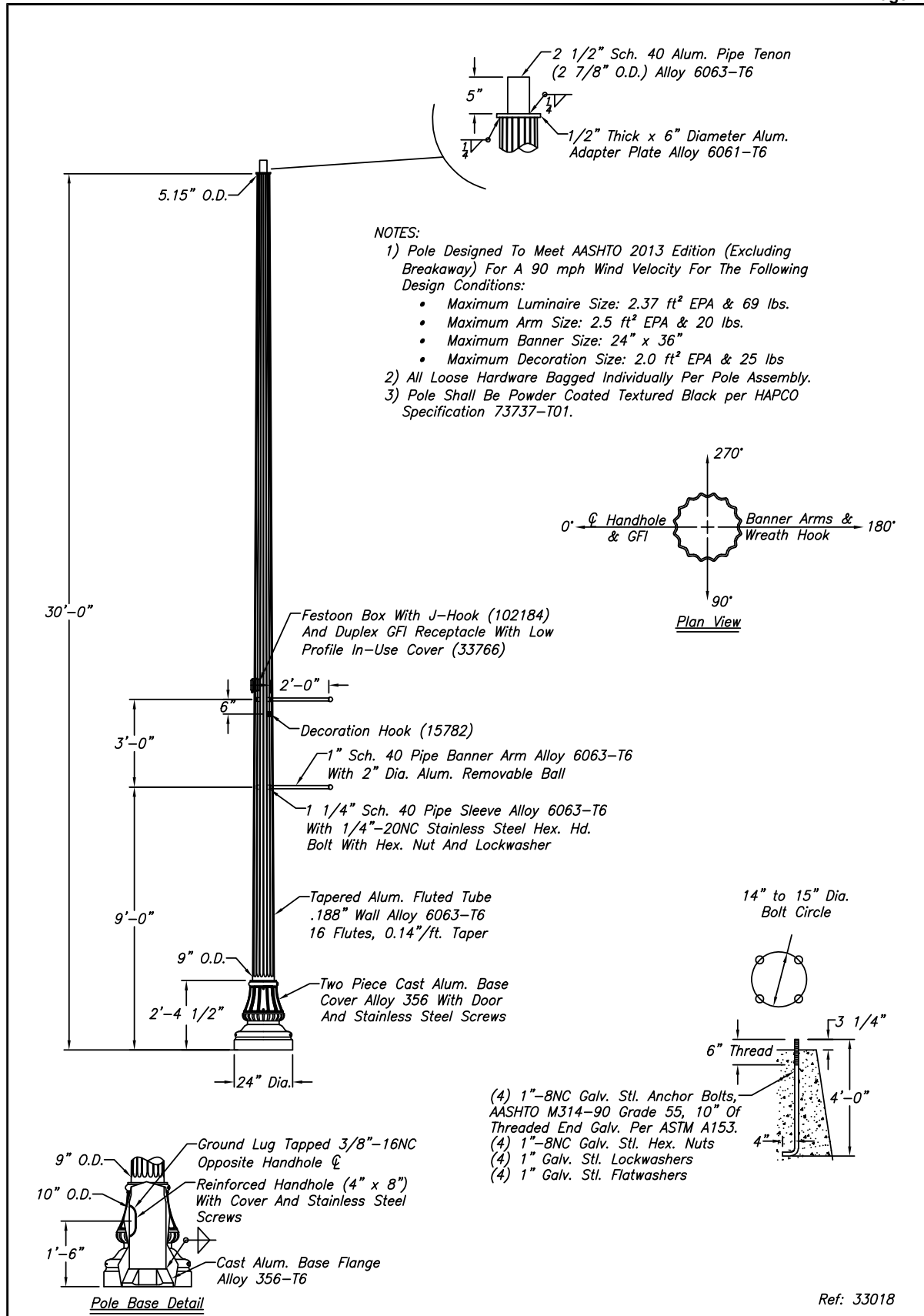

B104012

WARNING: DO NOT INSTALL LIGHTING POLES WITHOUT LUMINAIRES		
NO.	REVISIONS	DATE
Abingdon, Va.		
TITLE ARLEN SERIES LIGHTING POLE		CUSTOMER Otter Tail
SCALE 3/2	DATE 03/31/2020	
BY TNB	DWG. NO.	
CHK'D	B104012	

Granville II LED

Prismatic Style: Glass Classic
Housing Size: Utility

DECORATIVE OUTDOOR



THIS DRAWING, WHEN APPROVED, SHALL BECOME THE COMPLETE SPECIFICATION FOR THE MANUFACTURE OF THE PRODUCT DESCRIBED HEREIN. THE INFORMATION CONTAINED ON THE ORDER NOTED ABOVE A UNIT OF SIMILAR DESIGN MAY BE SUPPLIED, BUT ONLY AFTER APPROVAL BY THE CUSTOMER IN WRITING. ON POLE ORDERS AN ANCHOR-BOLT TEMPLATE PRINT WILL BE PROVIDED. THIS PRINT IS THE PROPERTY OF HOLOPHANE AND IS LOANED SUBJECT TO RETURN UPON DEMAND AND UPON EXPRESS CONDITION THAT IT WILL NOT BE USED DIRECTLY OR INDIRECTLY IN CONNECTION WITH MATERIAL FURNISHED BY HOLOPHANE.

ORDER #:
TYPE:
DRAWN: RAF
DATE: 6-29-2016
DWG #: LUM_GVD2U
1 of 4

Maximum weight - 47 lbs
Maximum effective projected area - 1.38 sq. ft.

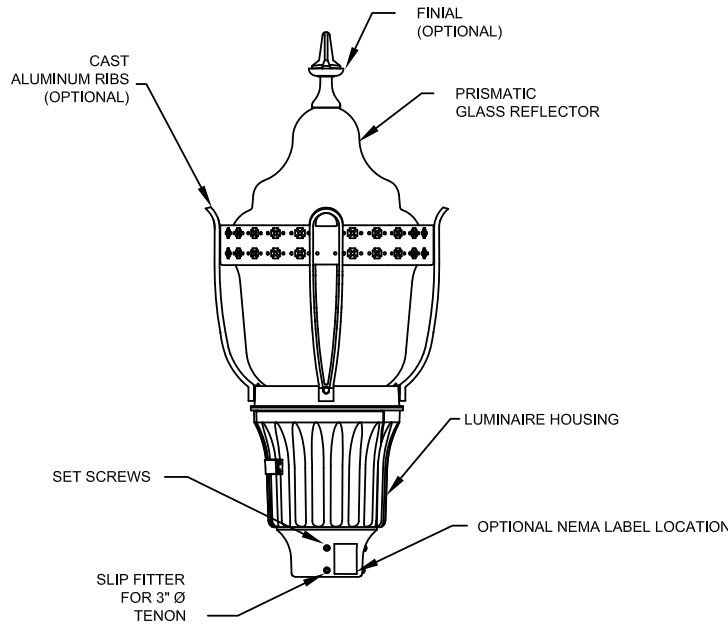
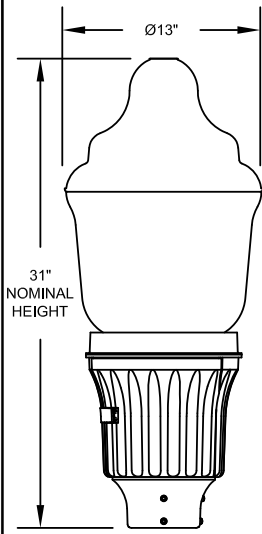

*drawing depicting base model no final.

ORDERING INFORMATION:

GVD2 P20 40K

HOUSING
GVD2 = GRANVILLE CLASSIC UTILITY

LED PERFORMANCE PACKAGE
(SEE PRODUCT COMPATIBILITY TABLE FOR OPTIONS)
P10 = AS=26W / AH=33W
P20 = AS=39W / AH=49W
P30 = AS=60W / AH=68W
P40 = AS=81W / AH=90W
P50 = AS=100W / AH=100W

COLOR TEMPERATURE
30K = 3000 K CCT
40K = 4000 K CCT
50K = 5000 K CCT

HOUSING
M = MODERN STYLE SWING OPEN DESIGN
T = LEAF STYLE SWING OPEN DESIGN

VOLTAGE
AS = AUTO-SENSING VOLTAGE (120 THRU 277 V)
AH¹ = AUTO-SENSING VOLTAGE (347 THRU 480 V)

HOUSING COLORS
BK = BLACK
BZ = BRONZE
GH = GRAPHITE
GN = GREEN
GR = GREY
PP = PRIME PAINT
WH = WHITE
CMC = CUSTOM MATCH COLOR
TDC = TIGER DRYLAC COLOR (RAL:xxx)
XX = STD FINISH, TBD

OPTICS
(SEE PRODUCT COMPATIBILITY TABLE FOR OPTIONS)
3 = IES TYPE III DISTRIBUTION
5 = IES TYPE V DISTRIBUTION
6 = IES TYPE III LUNAR OPTIC
8 = IES TYPE V LUNAR OPTIC

FINIAL
B = BALL
C = CLEAR
E = EAGLE
F = FLOWER
N² = NONE
P = PAWN
R = CROSS
S = STANDARD
T = ROM CROSS

TRIM/FINIAL COLORS
BK = BLACK
BZ = BRONZE
GL = GOLD
GH = GRAPHITE
GN = GREEN
GR = GREY
PP = PRIME PAINT
WH = WHITE
CMC = CUSTOM MATCH COLOR
TDC = TIGER DRYLAC COLOR (RAL:xxx)
XX = STD FINISH, TBD
U³ = NO TRIM & CLEAR OR NO FINIAL

TRIM
R = RIBS & BAND
N = NO TRIM
S = SYRACUSE STYLE WITH COVER (M HOUSING ONLY)

OPTIONS

CONTROL OPTIONS
AO⁴ = FIELD ADJUSTABLE OUTPUT
DE⁵ = ROAM 0 - 10V DIMMING CONTROL, INCLUDES NEMA TWISTLOCK PHOTOCONTROL RECEPTACLE
FPDxx⁶ = FACTORY PROGRAMMED DRIVER (xx = % OF LUMENS OR WATTS)
H⁷ = NEMA TWISTLOCK PHOTOCONTROL (PC) RECEPTACLE - 3 PIN
P5⁸ = DIMMING PC RECEPTACLE - 5 PIN
P7⁹ = DIMMING PC RECEPTACLE - 7 PIN
PCLL¹⁰ = LONG LIFE DTL TWISTLOCK PHOTOCONTROL FOR SOLID STATE
PCS¹¹ = DTL TWISTLOCK PHOTOCONTROL FOR SOLID STATE
PND¹² = 0-10V PART-NIGHT DIMMING, INCLUDES BLC2 & NEMA TWISTLOCK PHOTOCONTROL RECEPTACLE
PSC¹³ = SHORTING CAP

COVER OPTIONS
F¹⁴ = FULL COVER
M¹⁵ = MAYFIELD 1/2 COVER

NEMA WATTAGE LABEL OPTIONS
NL1X1 = 1 X 1 NEMA LABEL
NL2X2 = 2 X 2 NEMA LABEL

PREWIRE LEAD OPTIONS
L1H = 1.5 FEET OF PREWIRED LEADS
L03 = 3 FEET OF PREWIRED LEADS
L10 = 10 FEET OF PREWIRED LEADS
L20 = 20 FEET OF PREWIRED LEADS
L25 = 25 FEET OF PREWIRED LEADS
L30 = 30 FEET OF PREWIRED LEADS

ACCESSORIES

DECORATIVE BAND OPTIONS
GVBANDX¹⁶ = DECORATIVE BAND (INSERT TRIM FINISH FOR X), FOR EXAMPLE: GVBANDBK (BLACK)

HOUSE SIDE SHIELD OPTIONS
GVDHSS90¹⁷ = HOUSE SIDE SHIELD SOLID 90 DEGREE
GVDHSS120¹⁷ = HOUSE SIDE SHIELD SOLID 120 DEGREE
GVDHSS180¹⁷ = HOUSE SIDE SHIELD SOLID 180 DEGREE
GVDHSL90¹⁸ = HOUSE SIDE SHIELD SOLID 90 DEGREE (LUNAR)
GVDHSL120¹⁸ = HOUSE SIDE SHIELD SOLID 120 DEGREE (LUNAR)
GVDHSL180¹⁸ = HOUSE SIDE SHIELD SOLID 180 DEGREE (LUNAR)

NOTES ARE LOCATED ON PAGE 3

Performance Data

AS Voltage Option Data

LED Package	Distribution	System Watts	30K (3000K, 70 CRI)					40K (4000K, 70 CRI)					50K (5000K, 70 CRI)				
			Lumens	LPW	B	U	G	Lumens	LPW	B	U	G	Lumens	LPW	B	U	G
P10	3	26	3,024	116	1	3	3	3,180	122	1	3	3	3,180	122	1	3	3
	5	26	3,023	116	2	3	2	3,179	122	2	3	2	3,179	122	2	3	2
P20	3	39	4,990	128	2	4	4	5,247	135	2	4	4	5,247	135	2	4	4
	5	39	4,988	128	3	4	3	5,245	134	3	4	3	5,245	134	3	4	3
P30	3	60	7,076	118	2	5	4	7,440	124	2	5	4	7,440	124	2	5	4
	5	60	7,074	118	3	4	3	7,438	124	3	5	3	7,438	124	3	5	3
P40	3	81	8,847	109	3	5	5	9,303	115	3	5	5	9,303	115	3	5	5
	5	81	8,845	109	3	5	4	9,300	115	4	5	4	9,300	115	4	5	4
P50	3	100	10,359	104	3	5	5	10,892	109	3	5	5	10,892	109	3	5	5
	5	100	10,356	104	4	5	4	10,889	109	4	5	4	10,889	109	4	5	4

AH Voltage Option Data

LED Package	Distribution	System Watts	30K (3000K, 70 CRI)					40K (4000K, 70 CRI)					50K (5000K, 70 CRI)				
			Lumens	LPW	B	U	G	Lumens	LPW	B	U	G	Lumens	LPW	B	U	G
P10	3	33	3,024	92	1	3	3	3,180	96	1	3	3	3,180	96	1	3	3
	5	33	3,023	92	2	3	2	3,179	96	2	3	2	3,179	96	2	3	2
P20	3	49	4,990	102	2	4	4	5,247	107	2	4	4	5,247	107	2	4	4
	5	49	4,988	102	3	4	3	5,245	107	3	4	3	5,245	107	3	4	3
P30	3	68	7,076	104	2	5	4	7,440	109	2	5	4	7,440	109	2	5	4
	5	68	7,074	104	3	4	3	7,438	109	3	5	3	7,438	109	3	5	3
P40	3	90	8,847	98	3	5	5	9,303	103	3	5	5	9,303	103	3	5	5
	5	90	8,845	98	3	5	4	9,300	103	4	5	4	9,300	103	4	5	4
P50	3	100	10,359	104	3	5	5	10,892	109	3	5	5	10,892	109	3	5	5
	5	100	10,356	104	4	5	4	10,889	109	4	5	4	10,889	109	4	5	4

FPDxx Data Table (Only Available With AS Option)

FPDxx setting		P10 30K		P10 40K		P10 50K	
		Not Available		Not Available		Not Available	
FPDxx setting	AS Wattage	P20 30K		P20 40K		P20 50K	
Standard	39	4,990	4,988	5,247	5,245	5,247	5,245
FPD95	38	4,770	4,768	5,016	5,014	5,016	5,014
FPD90	36	4,546	4,545	4,781	4,779	4,781	4,779
FPD85	34	4,320	4,318	4,543	4,541	4,543	4,541
FPD80	32	4,091	4,089	4,301	4,300	4,301	4,300
FPD75	30	3,858	3,856	4,057	4,055	4,057	4,055
FPDxx setting	AS Wattage	P30 30K		P30 40K		P30 50K	
Standard	60	7,076	7,074	7,440	7,438	7,440	7,438
FPD95	57	6,897	6,895	7,252	7,250	7,252	7,250
FPD90	54	6,696	6,694	7,040	7,038	7,040	7,038
FPD85	51	6,473	6,471	6,806	6,804	6,806	6,804
FPD80	48	6,229	6,227	6,549	6,547	6,549	6,547
FPD75	45	5,964	5,963	6,271	6,269	6,271	6,269
FPDxx setting	AS Wattage	P40 30K		P40 40K		P40 50K	
Standard	81	8,847	8,845	9,303	9,300	9,303	9,300
FPD95	76	8,549	8,547	8,989	8,986	8,989	8,986
FPD90	72	8,233	8,231	8,657	8,654	8,657	8,654
FPD85	68	7,900	7,898	8,307	8,304	8,307	8,304
FPD80	64	7,549	7,547	7,938	7,936	7,938	7,936
FPDxx setting	AS Wattage	P50 30K		P50 40K		P50 50K	
Standard	100	10,359	10,356	10,892	10,889	10,892	10,889
FPD95	95	10,097	10,094	10,616	10,613	10,616	10,613
FPD90	90	9,802	9,799	10,306	10,304	10,306	10,304
FPD85	85	9,476	9,473	9,963	9,960	9,963	9,960

Granville II LED
Prismatic Style: Glass Classic
Housing Size: Utility

DECORATIVE
OUTDOOR



THIS DRAWING, WHEN APPROVED, SHALL BECOME THE COMPLETE SPECIFICATION FOR THE MANUFACTURE OF THE PRODUCT DESCRIBED HEREON. THE ORDER NOTED ABOVE A UNIT OF SIMILAR DESIGN MAY BE SUPPLIED, BUT ONLY AFTER APPROVAL BY THE CUSTOMER IN WRITING. ON POLE ORDERS AN ANCHOR BOLT TEMPLATE PRINT WILL BE PROVIDED. THIS PRINT IS THE PROPERTY OF HOLOPHANE AND IS LOANED SUBJECT TO RETURN UPON DEMAND AND UPON EXPRESS CONDITION THAT IT WILL NOT BE USED DIRECTLY OR INDIRECTLY IN CONNECTION WITH MATERIAL FURNISHED BY HOLOPHANE.

ORDER #: _____
TYPE: _____
DRAWN: RAF
DATE: 6-29-2016
DWG #: LUM_GVD2U

GranVille II LED
Prismatic Style: Glass Classic
Housing Size: Utility

DECORATIVE
OUTDOOR



THIS DRAWING, WHEN APPROVED, SHALL BECOME THE COMPLETE SPECIFICATION FOR THE MATERIAL TO BE FURNISHED BY HOLOPHANE ON THE ORDER NOTED ABOVE. A UNIT OF SIMILAR DESIGN MAY BE SUPPLIED, BUT ONLY AFTER APPROVAL BY THE CUSTOMER IN WRITING. ON POLE ORDERS AN ANCHOR BOLT TEMPLATE PRINT WILL BE PROVIDED. THIS PRINT IS THE PROPERTY OF HOLOPHANE AND IS LOANED SUBJECT TO RETURN UPON DEMAND AND UPON EXPRESS CONDITION THAT IT WILL NOT BE USED DIRECTLY OR INDIRECTLY IN CONNECTION WITH MATERIAL FURNISHED BY HOLOPHANE.

ORDER #: _____
TYPE: _____
DRAWN: RAF
DATE: 6-29-2016
DWG #: LUM_GVD2U

NOTES

1. Not available with "AO", "DE", "FPDXX", "PCLL", "PCS" or "PND".
2. Not available with cover options "F" or "M".
3. Only use if "N" for Trim and either "C" or "N" for Finial is selected.
4. Not available with "AH", "DE", "P5", "P7" or "PND". Refer to instructions on website for details.
5. Not available with "AO", "AH", "H", "PCLL", "PCS", "PSC" or "PND".
6. Refer to the FPDxx Data Table for lumens and wattages options.
7. Photocontrol not included. Not available with option "DE", "PND", "P5" or "P7".
8. Photocontrol not included. Not available with options "DE", "H", "PND" and "P7".
9. Photocontrol not included. Not available with options "DE", "H", "PND" and "P5".
10. Requires "H", "P5", "P7" or "PND". Not available with "AO", "PCS" or "PSC" options.
11. Available with "AS" voltage only. Requires "H", "P5", "P7" or "PND". Not available with "AO", "PCLL" or "PSC" options.
12. Available with "AS" voltage only. Not available with options "AO", "DE", "H", "P5" and "P7".
13. Requires "H", "P5" or "P7" option photocontrol receptacle or "PND" (includes photocontrol receptacle). Not available with "PCLL" or "PCS".
14. Not available with "N" finial option or "M" option.
15. Not available with "N" finial option or "F" option.
16. Field installed. For use with units without factory installed ribs and band. X = Trim/Finial Color.
17. Field installed, for use with Optic "3" or "5" only.
18. Field installed, for use with Optic "6" or "8" only.

Product Compatibility Table

LUMINAIRE, HOUSING & LED PACKAGE CONFIGURATIONS			
LUMINAIRE	HOUSING		LED PACKAGE
GVD2	M	Modern style - Swing open design	P10, P20, P30,
	T	Leaf Style - Swing open design	P40, P50

WATTAGE TABLE		
LED PACKAGE	AS	AH
P10	26W	33W
P20	39W	49W
P30	60W	68W
P40	81W	90W
P50	100W	100W

OPTICS/HOUSING/LED CONFIGURATION		
OPTICS	HOUSING	LED PACKAGE
3	A, C, F, L, S, M, T	P10, P20, P30,
5		P40, P50
6	A, C, F, L, S, M, T	P10, P20, P30, P40
8		

Lumen Ambient Temperature (LAT) Multipliers

Use these factors to determine relative lumen output for average ambient temperatures from 0-40°C (32-104°F).

Average Lumen Ambient Temperature (LAT) Multipliers			
°C	°F	Lumen Multiplier	LED Packages
0	32	1.06	P10, P20, P30, P40, P50
5	41	1.05	
10	50	1.04	
15	59	1.03	
20	68	1.01	
25	77	1.00	
30	86	0.99	
35	95	0.97	
40	104	0.96	

Projected LED Lumen Maintenance

Data references the extrapolated performance projections for the platforms noted in a 25°C ambient, based on 10,000 hours of LED testing (tested per IESNA LM-80-08 and projected per IESNA TM-21-11).

To calculate LLF, use the lumen maintenance factor that corresponds to the desired number of operating hours below. For other lumen maintenance values, contact factory.

Lumen Maintenance - LLD (same for all LED packages)							
Hours	0	25,000	36,000	50,000	60,000	75,000	100,000
Factor	1	0.93	0.93	0.92	0.91	0.9	0.89

The italicized data is extrapolated beyond the TM-21 standard.

$E = (LM) \times (CU) \times (LAT) \times (LLD)$
LM and CU are obtained from published photometry.

GranVille II LED
Prismatic Style: Glass Classic
Housing Size: Utility

**DECORATIVE
OUTDOOR**

HOLOPHANE
LEADER IN LIGHTING SOLUTIONS
An Acuity Brands Company
© 2009 Acuity Brands Lighting, Inc. All Rights Reserved

THIS DRAWING, WHEN APPROVED, SHALL BECOME THE COMPLETE SPECIFICATION FOR THE MANUFACTURE OF THE COMPLETE LUMINAIRE. THE ORDER NOTED ABOVE A UNIT OF SIMILAR DESIGN MAY BE SUPPLIED, BUT ONLY AFTER APPROVAL BY THE CUSTOMER IN WRITING. ON POLE ORDERS AN ANCHOR BOLT TEMPLATE PRINT WILL BE PROVIDED. THIS PRINT IS THE PROPERTY OF HOLOPHANE AND IS LOANED SUBJECT TO RETURN UPON DEMAND AND UPON EXPRESS CONDITION THAT IT WILL NOT BE USED DIRECTLY OR INDIRECTLY IN CONNECTION WITH MATERIAL FURNISHED BY HOLOPHANE.

ORDER #: _____
TYPE: _____
DRAWN: RAF
DATE: 6-29-2016
DWG #: LUM_GVD2U

Mark Appropriate Box for Trim Option

Housing

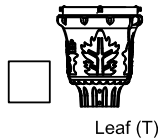
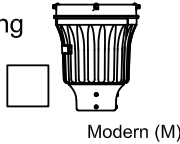

Cover

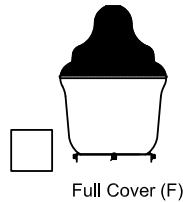
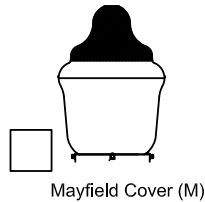
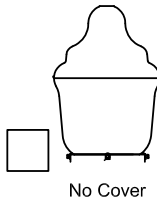

Ribs & Bands

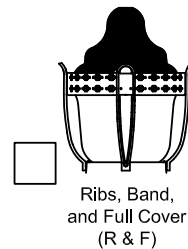
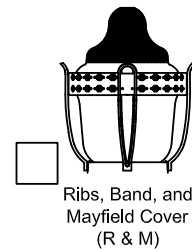
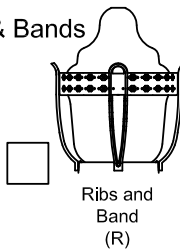

Finial

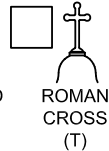
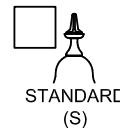
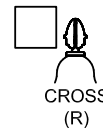
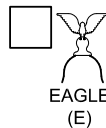
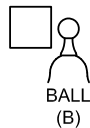
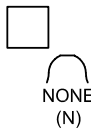

Specifications

GENERAL DESCRIPTION

The GranVille II LED Utility is designed for ease of maintenance with the plug-in electrical module common to each of the luminaires in Holophane's Utility Luminaire Series. The traditional acorn shaped luminaire, while reminiscent of the 1920's, contains a precision optical system that maximizes post spacings while maintaining uniform illumination.

OPTICAL SYSTEM

The optical system consists of a precisely molded thermal resistant borosilicate glass refractor and top reflector mounted within the decorative aluminum housing. The glass top reflector redirects over 50% of the upward light into the controlling refractor while allowing a soft uplight component to define the traditional acorn shape of the luminaire. Two decorative aluminum covers are available. The lower refractor uses precisely molded prisms to maximize pole spacings while maintaining uniform illuminance. Two refractors are available, designed for I.E.S. type III and V distributions. Lunar optics shielding is available for asymmetric and symmetric distribution.

LUMINAIRE HOUSING

The luminaire housing, cast of aluminum, provides an enclosure for the plug-in electrical module. Four uniquely designed stainless steel spring clips enclosed in a clear polyvinyl chloride sleeve and adjusted by hex head 1/4-20 bolts securely cradle the prismatic glass refractor. The same 1/4-20 bolts support the decorative rib and banding assembly. The slipfitter will accept a 3" by 2-7/8" to 3-1/8" O.D. tenon.

LUMINAIRE HOUSING / DOOR

Cast of aluminum, the housing opens with minimum use of tools and is retained on a hinge. For units with an E.E.I.-N.E.M.A. twist lock photocell receptacle, the housing contains a "window" to allow light to reach the cell.

ELECTRICAL MODULE

The electrical components are mounted on a aluminum plate that is removable with minimum use of tools. A matching five conductor plug connects to the receptacle in the luminaire housing to complete the wiring. For photoelectric operation, the electrical module is provided with an E.E.I.-N.E.M.A. twist lock photocell receptacle.

DRIVER

AS drivers are programmable dimmable drivers, with 0-10V control leads and AH drivers are dimmable (0-10V) drivers.

FINISH

The luminaire is finished with polyester powder paint to insure maximum durability.

WARRANTY

Limited warranty located at <http://www.acuitybrands.com/resources/terms-and-conditions>.

NOTE

Luminaire is CSA listed for Wet Locations.

Luminaire housing is IP55 rated. Optical chamber is IP66 rated.

Specification subject to change without notice.



Catalog Number	
Notes	Type

AUCL2

Utility Arlington Series Luminaire Full Cutoff LED2



Mechanical

- Heavy grade A360 cast aluminum (<1% copper)
- Tool-less access with a spring-loaded latch
- Hidden hinge door allowing the door to swing open and remain open
- Optional internal or external NEMA twist lock photocontrol receptacle. Housing contains a tempered glass window to allow light to reach the cell for internal versions.
- Mount to slip-fitter that will accept 3" high by 2-7/8" to 3-1/8" O.D. pole tenon
- Decorative top cover contains stainless steel hinge which secures entry the LED optical chamber
- Polyester power coat paint to ensure maximum durability
- Finish meets 5,000-hour salt spray testing
- Holophane and RAL Classic finishes.

Electrical

- All surge protection meets ANSI/IEEE C62.41.2 10kV/10kA.
- Standard SPD meets 10kV/5kA per ANSI C136.2-2015.
- 20KV Option meets 20kV/10kA per ANSI C136.2-2015.
- Quick disconnect connectors for ease of installation and maintenance.
- Three pole terminal block is standard, with optional prewired leads for ease of installation
- LED drivers meet maximum total harmonic distortion (THD) of 20%, >0.90 Power Factor and are ROHS compliant. Minimum operating temperature is -40C. Electronic driver has an estimated minimum life of 100,000 hours at 25°C.

Optical

- IP65 rated optical compartment
- LED circuit board located in the top cover
- Asymmetric or Symmetric full cutoff distributions
- 2700K, 3000K, 4000K, and 5000K CCT
- 70CRI Standard

Control Options

- Field Adjustable Output (AO) module - Onboard device that adjusts the light output and input wattage to meet site specific requirements. The AO module is preset at the factory to position number 8 (see chart).
- Wireless remote control for monitoring performance and/or maintenance of the system – ROAM
- Factory Programmed Driver (FPDxx) - Customize lumen output prior to manufacturing and still enables control leads so other options can also be used
- Long Life Photocontrols (PCLL) - 20 Year Life
- 3 and 7 pin photocontrol receptacles internally (P3, P7) or externally (P3E, P7E) mounted
- Part-night dimming (PND) enables luminaire to monitor and adjust 50% lumens based on season and geographic location, 8-day rolling average

Testing/Compliance

- UL 1598 - Wet Locations Safety Listing
- Suitable for ambient temperatures -40°C to 40°C
- DesignLights Consortium® (DLC) qualified product. Not all versions of this product may be DLC qualified. Please check with the DLC Qualified Products List at www.designlights.org/QPL for updated list

Manufacturing

- Manufactured in Crawfordsville, Indiana, ARRA compliant
- 100% electrical testing on all luminaires before shipment
- Ten (10) years minimum experience in manufacturing LED based products

Warranty

5-year limited warranty. Complete warranty terms located at: www.acuitybrands.com/CustomerResources/Terms_and_Conditions.aspx.

Note: Actual performance may differ as a result of end-user environment and application. All values are design or typical values, measured under laboratory conditions at 25°C. Specifications subject to change without notice.



DIMENSIONAL DATA

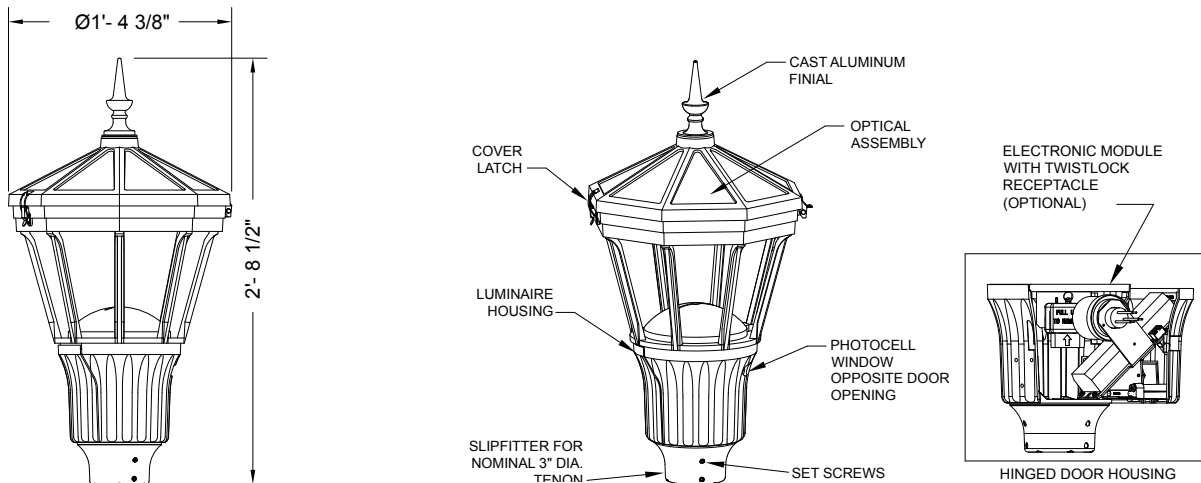

Maximum Weight - 40 lbs
Maximum Effective Projected Area - 1.38 sq. ft.



AUCL2

Utility Arlington Series Luminaire Full Cutoff LED2

ORDERING INFORMATION

Example: AUCL2 P20 30K AS GN L2 N P7E

Series	Led performance package	LED Color temperature	Voltage	Housing color	Optics	Finial
AUCL2 Utility Arlington LED FCO	P10 1,500 nominal lumens (amber only)	AM True amber 27K 2700K CCT	AS Auto-sensing voltage (120 thru 277) 50/60 HZ	BK Black	L2 Type 2 distribution full cutoff	N None
	P20 4,500 nominal lumens	27K 2700K CCT		GR Gray		B Ball
	P30 6,500 nominal lumens	30K 3000K CCT	AH Auto-sensing voltage (347 thru 480) 50/60 HZ	GH Graphite	L3 Type 3 distribution full cutoff	S Spike
	P40 8,500 nominal lumens	40K 4000K CCT		GN Green		
	P50 11,500 nominal lumens	50K 5000K CCT		PP Prime paint		
			WH White	L4 Type 4 distribution full cutoff		
			BZ Bronze	L5 Type 5 distribution full cutoff		
			TDC RAL Color color (RAL**)			
			CMC Custom color match			

Options: Option Compatibility Matrix on page 3 of 4

AO Field Adjustable Output	P3E NEMA Twist Lock Dimming Photocontrol Receptacle - 3 PIN. Externally mounted	L1H 1.5 ft prewired leads
DE ROAM Hardware DecoNode and DCM Factory Installed	P7E NEMA Twist Lock Dimming Photocontrol Receptacle - 7 PIN. Externally mounted	L03 3ft prewired leads
FPDxx Factory Programmed Driver	RME ROAM Node (External)	L10 10 ft prewired leads
P3 NEMA Twist Lock photocontrol receptacle - 3 PIN receptacle only.	RME3 347V ROAM NODE (External)	L20 20 ft prewired leads
P7 NEMA Twist Lock Dimming photocontrol receptacle - 7 PIN receptacle only.	RME4 480V ROAM NODE (External)	L25 25 ft prewired leads
PCS DTL twistoff photocontrol for solid-state lighting 120-277V	PSC Shorting cap	L30 30 ft prewired leads
PCLL DTL long life twistlock photocontrol for solid-state AS	HSS House side shield	NL1X1 NEMA Label 1" X 1"
P34 DTL long life twistlock photocontrol for solid-state 347V		NL2X2 NEMA Label 2" X 2"
P48 DTL long life twistlock photocontrol for solid-state 480V		20KV 20kV/10kA surge protection
PND Part night dimming - down to 50%		

Accessories: Order as separate catalog number.

XXCL2HSS1	Field Accessory - Louvered house side shield (Qty 1)
XXCL2HSSJ50	Field Accessory - Louvered house side shield (Bulk Qty 50)
XXCL2SPD10KAS	10kV/5kA Extreme surge 120-277V
XXCL2SPD10KAH	10kV/5kA Extreme surge 480V
XXCL2SPD20KAS	20kV/10kA Extreme surge 120-277V
XXCL2SPD20KAH	20kV/10kA Extreme surge 480V

FINIAL INFORMATION

Mark Appropriate Box for Finial Options

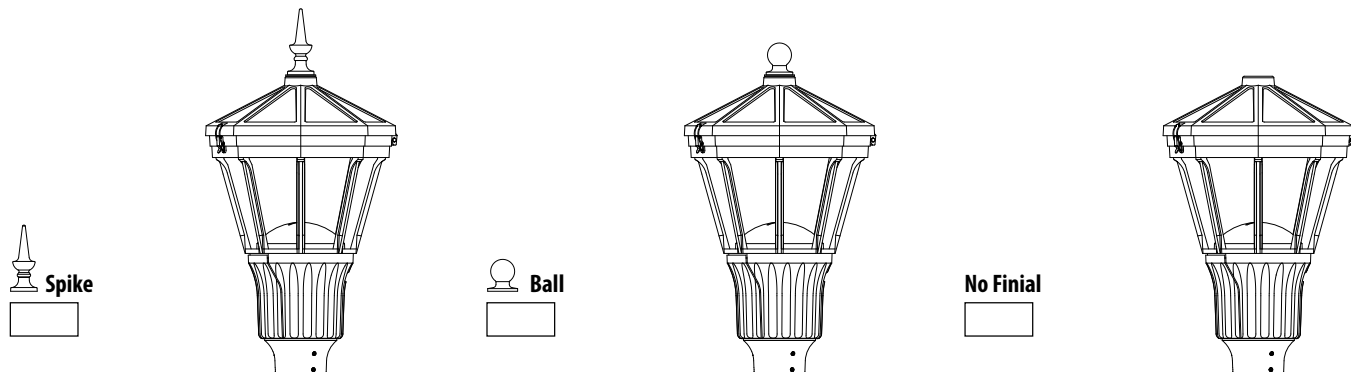



AUCL2

Utility Arlington Series Luminaire Full Cutoff LED2

OPTIONS MATRIX

Mounting	SELECTED OPTION (start here)																
	AO	DE	FPDxx	P3	P3E	P7	P7E	P34	P48	PCLL	PCS	PND	PSC	RME	RME3	RME4	20kV
LED Performance Package	P10	Y	Y	Y	Y	Y	Y	Y	Y	Y	Y	Y	Y	Y	Y	Y	Y
	P20	Y	Y	Y	Y	Y	Y	Y	Y	Y	Y	Y	Y	Y	Y	Y	Y
	P30	Y	Y	Y	Y	Y	Y	Y	Y	Y	Y	Y	Y	Y	Y	Y	Y
	P40	Y	Y	Y	Y	Y	Y	Y	Y	Y	Y	Y	Y	Y	Y	Y	Y
	P50	Y	N	Y	Y	Y	Y	Y	Y	Y	Y	N	Y	Y	Y	Y	N
Voltage	AS	Y	Y	Y	Y	Y	Y	N	N	Y	Y	Y	Y	Y	N	N	Y
	AH	Y	N	Y	Y	Y	Y	Y	Y	Y	N	N	Y	N	Y	Y	Y
Finial	B	Y	Y	Y	Y	N	Y	N	Y	Y	Y	Y	Y	N	N	N	Y
	S	Y	Y	Y	Y	N	Y	N	Y	Y	Y	Y	Y	N	N	N	Y
	N	Y	Y	Y	Y	M	Y	M	Y	Y	Y	Y	Y	M	M	M	Y
Compatible Options	AO	N	Y	Y	Y	F	F	Y	Y	Y	Y	N	Y	N	N	N	Y
	DE	N	Y	Y	N	N	N	N	N	N	N	N	Y	N	N	N	Y
	FPDxx	Y	Y	Y	Y	Y	Y	Y	Y	Y	Y	Y	Y	Y	Y	Y	Y
	P3	F	M	Y	N	N	N	Y	Y	Y	Y	M	Y	N	N	N	Y
	P3E	F	N	Y	N	N	N	Y	Y	Y	Y	N	Y	N	N	N	Y
	P7	F	N	Y	N	N	N	Y	Y	Y	Y	N	Y	N	N	N	Y
	P7E	F	N	Y	N	N	N	Y	Y	Y	Y	N	Y	I	I	I	Y
	P34	Y	N	Y	Y	Y	Y	Y	N	N	N	N	N	N	N	N	Y
	P48	Y	N	Y	Y	Y	Y	Y	N	N	N	N	N	N	N	N	Y
	PCLL	Y	N	Y	Y	Y	Y	Y	N	N	N	M	N	N	N	N	Y
	PCS	Y	N	Y	Y	Y	Y	Y	N	N	N	M	N	N	N	N	Y
	PND	N	N	Y	Y	N	N	N	N	N	M	M	Y	N	N	N	Y
	PSC	Y	N	Y	Y	Y	Y	Y	N	N	N	N	Y	N	N	N	Y
	RME	N	N	Y	N	N	N	Y	N	N	N	N	N	N	N	N	Y
	RME3	N	N	Y	N	N	N	Y	N	N	N	N	N	N	N	N	Y
	RME4	N	N	Y	N	N	N	Y	N	N	N	N	N	N	N	N	Y
	20kV	Y	Y	Y	Y	Y	Y	Y	Y	Y	Y	Y	Y	Y	Y	Y	Y

Y = Valid Option Combination

F = Future ready (wired with "AO", but could accept control device with tool-less field wiring)

M = Must have: one of these must be installed for the luminaire to operate

N = Combination Not available

ROAM OPTION DETAILS

DE = UL listed components without GPS capability, external antenna is black and includes ROAM capable node only, ROAM service package sold separately via Acuity Controls

RME = UL listed device without GPS capability, blue housing color, includes ROAM capable node only, ROAM service package sold separately via Acuity Controls and contact Acuity Controls for RME device with GPS capability or non-standard color

RME3 = UL listed device without GPS capability, green housing color, includes ROAM capable node only, ROAM service package sold separately via Acuity Controls and contact Acuity Controls for RME device with GPS capability or non-standard color

RME4 = UL listed device without GPS capability, yellow housing color, includes ROAM capable node only, ROAM service package sold separately via Acuity Controls and contact Acuity Controls for RME device with GPS capability or non-standard color

LUMEN AMBIENT TEMPERATURE (LAT) MULTIPLIERS

Use the factors to determine relative lumen output for average ambient temperatures from 0-40C (32-104F)

Ambient Temp (degrees C) Lumen Multiplier								
0	5	10	15	20	25	30	35	40
1.05	1.04	1.03	1.02	1.01	1.00	0.99	0.98	0.97

PROJECTED LED LUMEN MAINTENANCE

Data references the extrapolated performance projections for the platforms noted in 25C ambient, based on 6,000 hours of IED testing (tested per IESNA LM-80-08 and projected per IESNA TM-21-11). To calculate LLF, use the lumen maintenance factor that corresponds to the desired number of operating hours below. For other lumen maintenance values, contact factory.

Package	Lumen Maintenance						L70 Hrs
	25k hrs	36k hrs	50k hrs	60k hrs	75k hrs	100k hrs	
P20-P40	0.97	0.96	0.95	0.94	0.93	0.91	383,000
P50	0.96	0.94	0.93	0.91	0.90	0.87	267,667



AUCL2

Utility Arlington Series Luminaire Full Cutoff LED2

PERFORMANCE DATA

LED Package	Distribution	SystemWatts	2700K		3000K		4000K		5000K	
			Lumens	LPW	Lumens	LPW	Lumens	LPW	Lumens	LPW
P20	L2	45	3950	88	4037	90	4449	99	4583	102
	L3	45	3554	79	3631	81	4002	89	4123	92
	L4	45	3822	85	3906	87	4304	96	4434	99
	L5	45	3903	87	3988	89	4396	98	4528	101
P30	L2	66	5761	87	5887	89	6488	98	6684	101
	L3	66	5183	79	5296	80	5837	88	6013	91
	L4	66	5574	84	5696	86	6277	95	6467	98
	L5	66	5692	86	5816	88	6411	97	6604	100
P40	L2	89	7453	84	7616	86	8394	94	8647	97
	L3	89	6705	75	6851	77	7551	85	7779	87
	L4	89	7211	81	7368	83	8121	91	8366	94
	L5	89	7364	83	7525	85	8293	93	8544	96
P50	L2	139	10670	77	10903	78	12016	86	12379	89
	L3	139	9598	69	9808	71	10810	78	11136	80
	L4	139	10323	74	10548	76	11626	84	11977	86
	L5	139	10542	76	10772	77	11872	85	12231	88

FPDXX DATA OPTIONS

FPDxx Setting	Wattage	P20 27K				P20 30K				P20 40K				P20 50K			
		L2	L3	L4	L5	L2	L3	L4	L5	L2	L3	L4	L5	L2	L3	L4	L5
Standard	45	3950	3554	3822	3903	4037	3631	3906	3988	4449	4002	4304	4396	4583	4123	4434	4528
FPD95	43	3753	3376	3631	3708	3835	3450	3710	3789	4226	3802	4089	4176	4354	3917	4213	4302
FPD90	41	3755	3198	3440	3513	3633	3268	3515	3590	4004	3602	3874	3956	4125	3711	3991	4076
FPD85	38	3358	3021	3249	3318	3431	3087	3320	3390	3782	3402	3659	3736	3896	3505	3769	3849
FPD80	36	3160	2853	3058	3123	3229	2905	3124	3191	3559	3202	3444	3517	3667	3298	3547	3623
FPDxx Setting	Wattage	P30 27K				P30 30K				P30 40K				P30 50K			
		L2	L3	L4	L5	L2	L3	L4	L5	L2	L3	L4	L5	L2	L3	L4	L5
Standard	66	5761	5183	5574	5692	5887	5296	5696	5816	6488	5837	6277	6411	6684	6013	6467	6604
FPD95	63	5473	4924	5295	5408	5592	5031	5411	5526	6164	5545	5963	6090	6350	5712	6144	6274
FPD90	59	5185	4664	5017	5123	5298	4766	5126	5235	5839	5253	5650	5769	6016	5412	5820	5944
FPD85	56	4897	4405	4738	4838	5004	4501	4841	4944	5515	4961	5336	5449	5681	5411	5497	5613
FPD80	53	5369	4146	4459	4554	4709	4237	4557	4653	5190	4669	5022	5128	5347	4810	5173	5283
FPD75	50	4321	3887	4180	4269	4415	3972	4272	4362	4866	4378	4708	4808	5013	4510	4850	4953
FPD70	46	4033	3628	3902	3985	4121	3707	3987	4072	4542	4086	4394	4487	4679	4209	4527	4623
FPDxx Setting	Wattage	P40 27K				P40 30K				P40 40K				P40 50K			
		L2	L3	L4	L5	L2	L3	L4	L5	L2	L3	L4	L5	L2	L3	L4	L5
Standard	89	7453	6705	7211	7364	7616	6851	7368	7525	8394	7551	8121	8293	8647	7779	8366	8544
FPD95	85	7080	6370	6851	6996	7235	6509	7000	7149	7974	7173	7715	7879	8215	7390	7948	8116
FPD90	80	6708	6034	6490	6628	6854	6166	6632	6772	7544	6796	7309	7464	7782	7001	7530	7689
FPD85	76	6335	5699	6129	6259	6473	5824	6263	6396	7135	6418	6903	7049	7350	6612	7111	7262
FPD80	71	5962	5364	5769	5891	6093	5481	5895	6020	6715	6041	6497	6635	6918	6223	6693	6835
FPDxx Setting	Wattage	P50 27K				P50 30K				P50 40K				P50 50K			
		L2	L3	L4	L5	L2	L3	L4	L5	L2	L3	L4	L5	L2	L3	L4	L5
Standard	139	10670	9598	10323	10542	10903	9808	10548	10772	12016	10810	11626	11872	12379	11136	11977	12231
FPD95	132	10136	9119	9807	10015	11966	9318	10021	10234	11415	10269	11025	11279	11760	10579	11378	11619
FPD90	125	9603	8639	9291	9488	9812	8827	9494	9695	10814	9729	10463	10685	11141	10022	10779	11008
FPD85	118	9069	8159	8775	8961	9267	8337	8966	9156	10214	9188	9882	10092	10522	9466	10180	10396
FPD80	111	8536	7679	8259	8434	8722	7846	8439	8618	9613	8648	9301	9498	9903	8909	9581	9785

AUCL2

Utility Arlington Series Luminaire Full Cutoff LED2

COMPONENTS & OPTIONS DATA

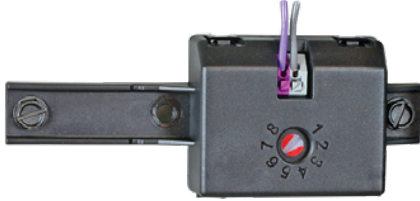

AO
Manual field adjustable output dimming device



RME (External)
Remote Asset Management Control Dimming Device
(specify with receptacle)

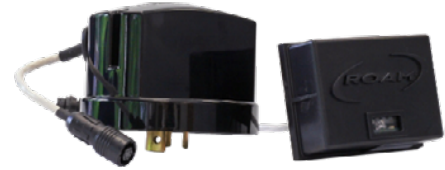

DE
Remote Asset Management Control Decorative Node
(specify with P3 receptacle)



20kV
Safeguard your investment from extreme voltage spikes with our new Extreme 20kV/10kA SPD



HSS
Minimize backlight with a louvered house-side-shield. Available as a factory option or field accessory