

CRANE PAD LOCATIONS TO BE DETERMINED BY CONTRACTOR BASED ON FIELD CONDITIONS
 TYPICAL WIND TURBINE SITE LAYOUT WITH COMPONENTS (LAYOUT 1)

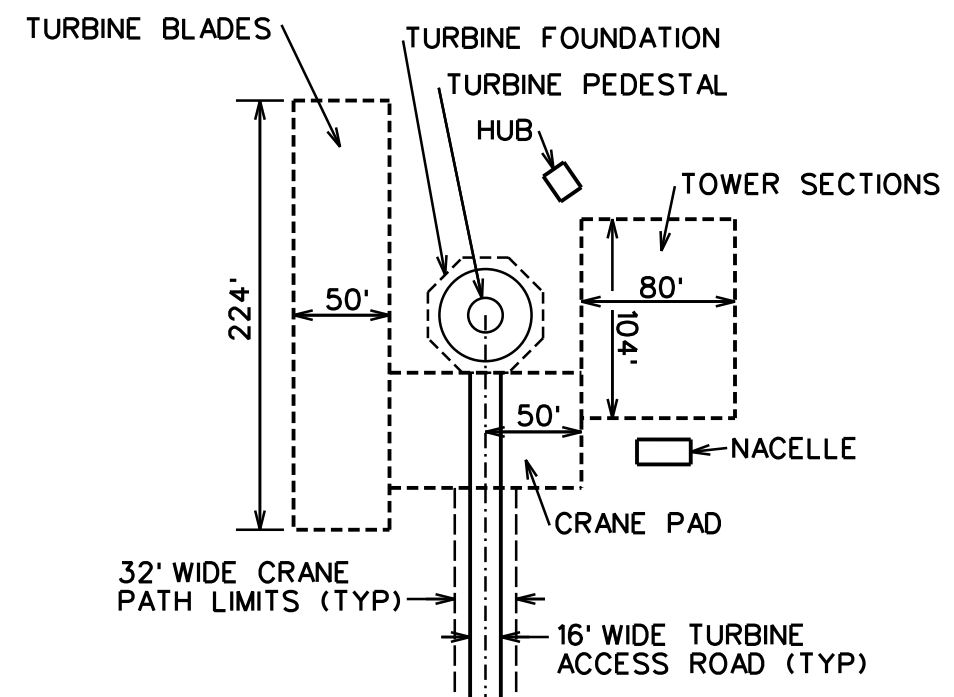

CRANE PAD LOCATIONS TO BE DETERMINED BY CONTRACTOR BASED ON FIELD CONDITIONS
 TYPICAL WIND TURBINE SITE LAYOUT WITH COMPONENTS (LAYOUT 2)

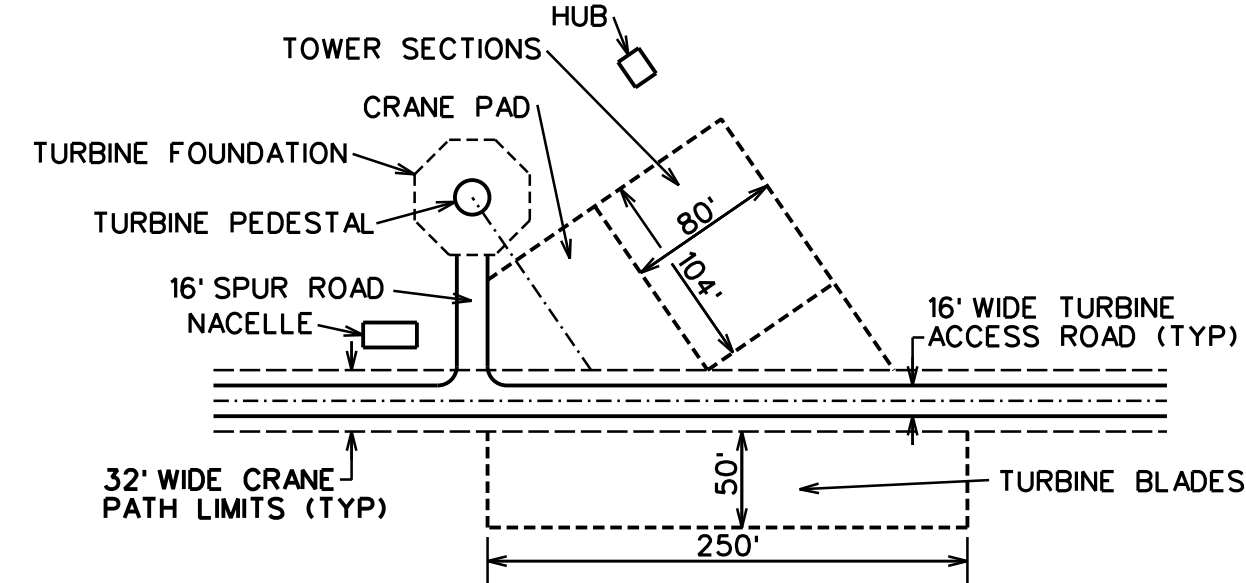

CRANE PAD LOCATIONS TO BE DETERMINED BY CONTRACTOR BASED ON FIELD CONDITIONS
 TYPICAL WIND TURBINE SITE LAYOUT WITH COMPONENTS (LAYOUT 3)

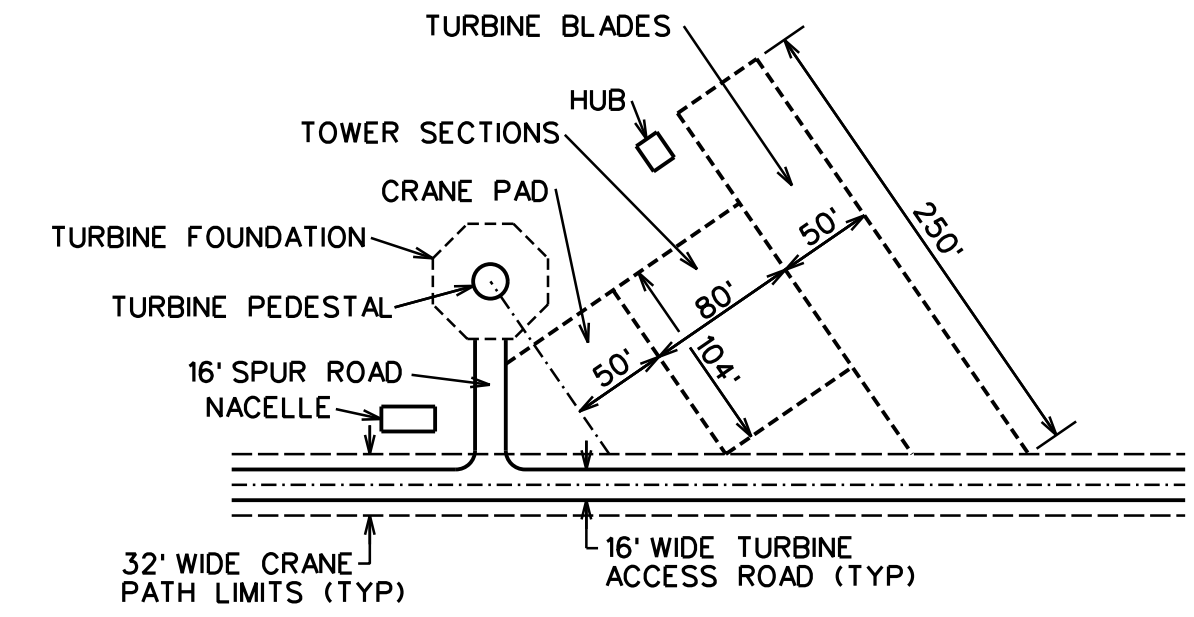

CRANE PAD LOCATIONS TO BE DETERMINED BY CONTRACTOR BASED ON FIELD CONDITIONS
 TYPICAL WIND TURBINE SITE LAYOUT WITH COMPONENTS (LAYOUT 4)

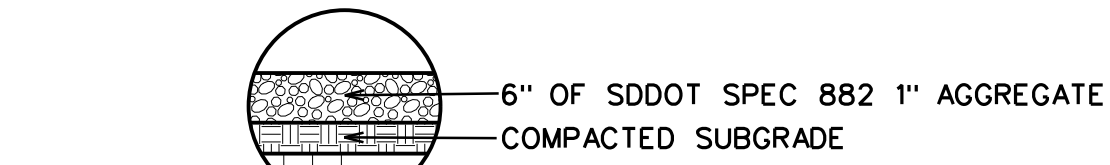

TURBINE ACCESS ROAD OPTION A

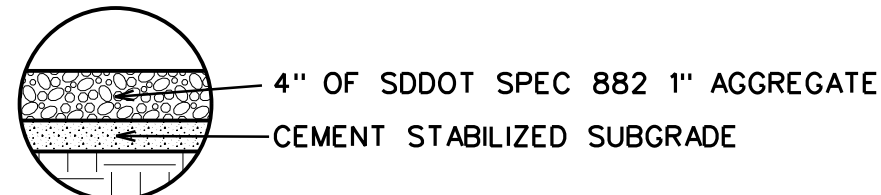

TURBINE ACCESS ROAD OPTION B

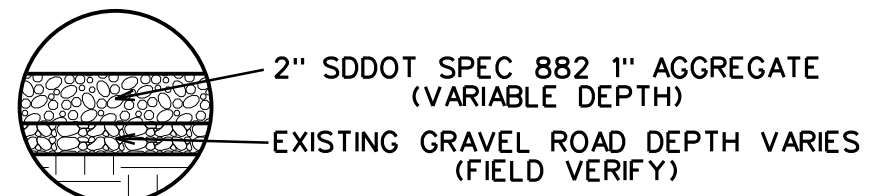

EXISTING GRAVEL ROAD UPGRADE

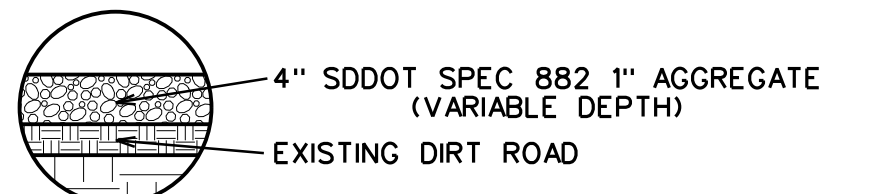

EXISTING DIRT ROAD UPGRADE

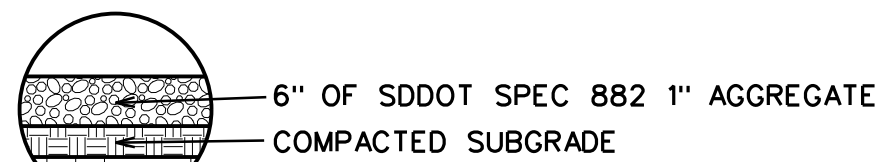

LAYDOWN YARD

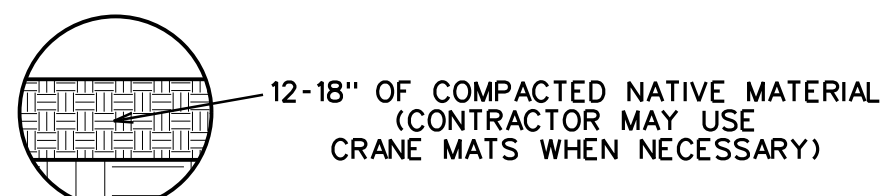

CRANE PAD

STRUCTURAL SECTIONS SHOWN ARE THE MINIMUM THICKNESS REQUIREMENTS DURING NORMAL FIELD CONDITIONS. THE SECTIONS MAY NEED TO BE INCREASED BASED ON ACTUAL FIELD CONDITIONS AT THE TIME OF CONSTRUCTION. CONDITIONS INCLUDE BUT ARE NOT LIMITED TO THE CONSTRUCTION DURING THE FREEZE/THAW CYCLE, UNUSUALLY WET PERIODS, OR IN LOW/WET AREAS.

TYPICAL CROSS SECTIONS

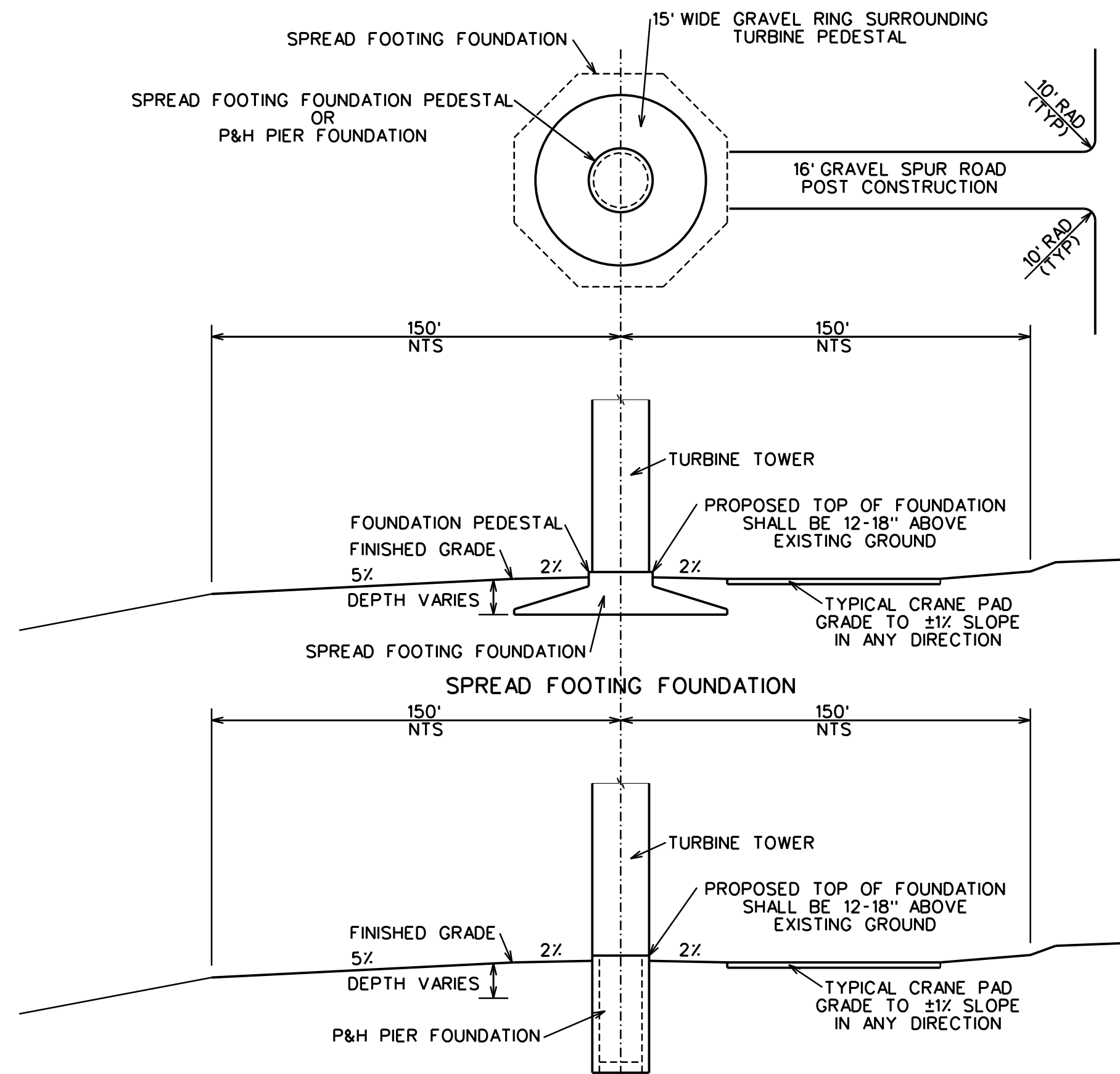

TYPICAL POST CONSTRUCTION DISTURBANCE AREA, FOUNDATION, SPUR ROAD FOR TURBINES AND PROFILE VIEW

FOUNDATION TYPE AND DIMENSIONS TO BE DETERMINED BY CONTRACTOR BASED ON FIELD CONDITIONS AND GEOTECH REPORT

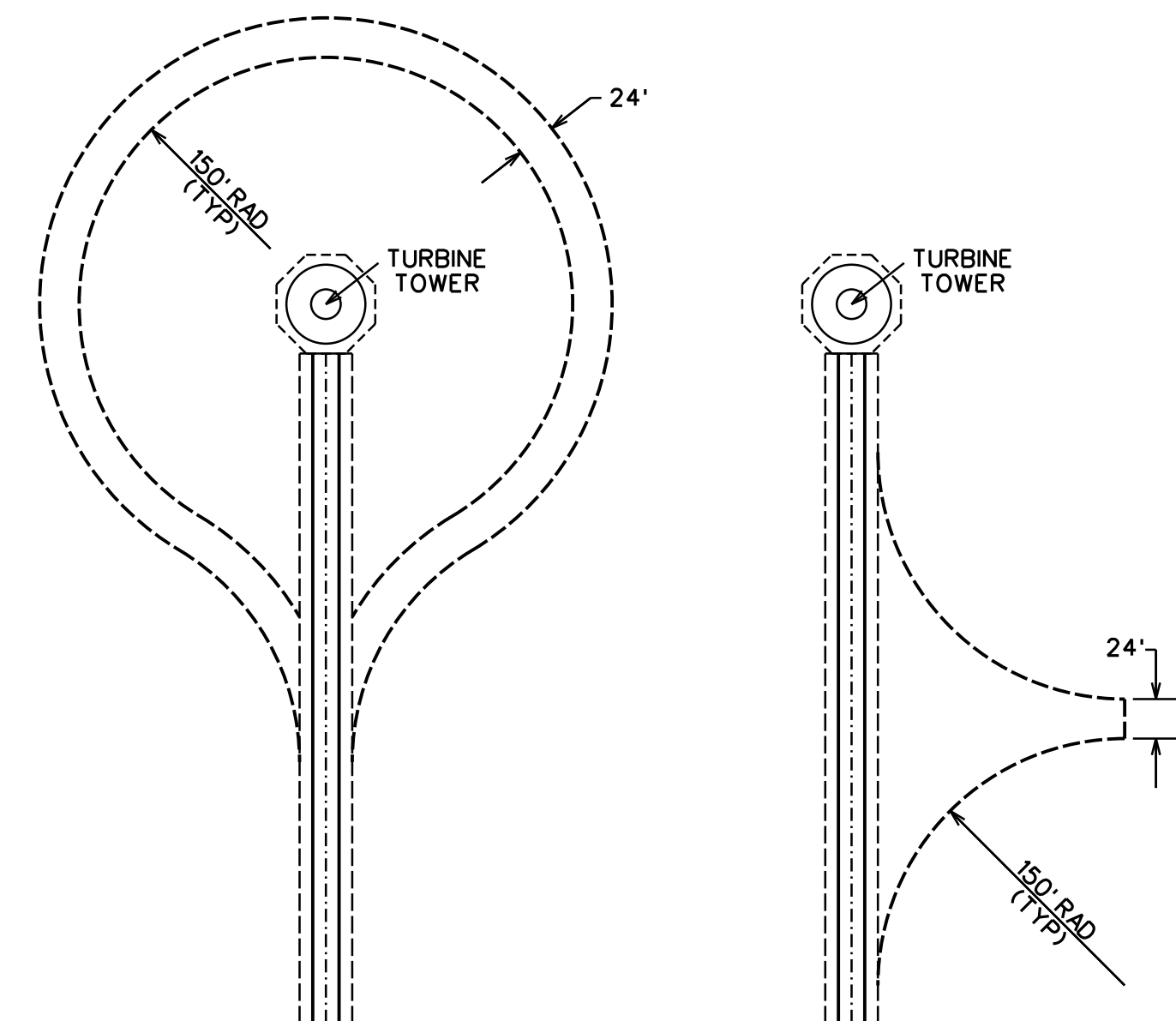

COMPONENT DELIVERY TRUCK TURNAROUND OPTIONS

MARK	REVISION	DATE	BY
Engineer: BJJ	Checked By: MGG	Scale: 1" = 100'	Field Bk:
Technician: DW	Date: 07-21-15	Project No: 1140140	Sheet 1 of 1

CROWNED RIDGE I & II, LLC
 TYPICAL TURBINE CONSTRUCTION SITE LAYOUT
 CODINGTON, DEUEL & GRANT COUNTIES, SOUTH DAKOTA
SNYDER & ASSOCIATES, INC.
 1751 MADISON AVENUE
 COUNCIL BLUFFS, IA 51503
 712-322-3202 | www.snyder-associates.com

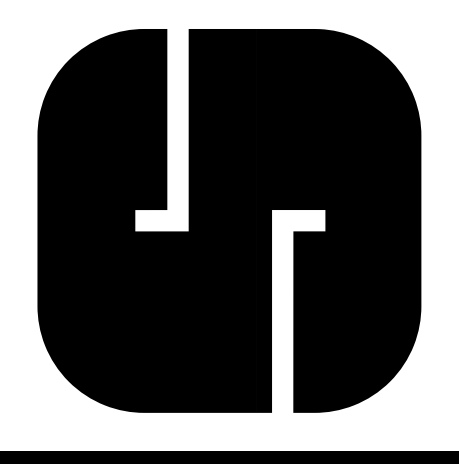

V:\RefrLibr\A\CADD\Standards\WorksSpace\Printing\PrintTables\Date.tbl
 V:\RefrLibr\A\CADD\Standards\WorksSpace\Printing\PrintDrivers\Color\18ColorFullPostscript.plt
 11/20/2018 6:49:02 AM
 DWIEDMEYER D:\1140140\CADD\1140140 TYPICAL TURBINE CONSTRUCTION SITE LAYOUT.dgn
 Snyder 1100