



T. R. I. M. E. C. S.

Technical Requirements for Interconnection of Generation to the
MidAmerican Energy Company Distribution System

REVISION 1.0

PREFACE 3

SECTION 1: INTRODUCTION..... 4

SECTION 2: SCOPE 5

SECTION 3: OVERVIEW OF THE *TRIMECS* APPROVAL PROCESS 5

SECTION 4: SPECIFIC INTERCONNECTION DESIGN CRITERIA 7

SECTION 5: GENERAL REQUIREMENTS FOR ALL INTERCONNECTIONS..... 8

SECTION 6: REQUIRED EQUIPMENT BASED UPON SIZE (GENERATION CAPACITY) 14

SECTION 7: REQUIRED EQUIPMENT BASED UPON TECHNOLOGY 14

SECTION 8: REQUIRED EQUIPMENT BASED UPON TRANSITION MODE..... 15

SECTION 9: REQUIRED EQUIPMENT BASED UPON INTENDED USE..... 18

SECTION 10: OPERATING REQUIREMENTS 19

SECTION 11: COMMISSION TESTING AND MAINTENANCE OF INTERCONNECTION EQUIPMENT 20

APPENDIX A: PRELIMINARY APPROVAL SUBMITTAL CHECKLIST..... 22

APPENDIX B: DESIGN APPROVAL SUBMITTAL CHECKLIST..... 25

APPENDIX C: FINAL APPROVAL SUBMITTAL CHECKLIST 29

APPENDIX D: DEFINITION OF TERMS AND ABBREVIATIONS USED IN *TRIMECS* 30

APPENDIX E: EXAMPLE DRAWINGS 35

APPENDIX F: CONTACT FORMS 36

APPENDIX R: INTERCONNECTION PROTECTIVE RELAY (IPR) ELEMENTS GUIDE..... 39

APPENDIX T: INTERCONNECTION PROTECTIVE RELAY DISCRETE TEST SHEET..... 43

APPENDIX U: SYNCHRONIZING DEVICE DISCRETE TEST SHEET..... 46

Preface

The following document contains several different formatting styles that have special meaning:

- ***Bold Italics*** terms and abbreviations indicate terms and abbreviations that are defined in an appendix at the end of the document.
- Underlined terms indicate the titles of other documents or sub-parts of documents that are referenced.

The terms “company”, “utility”, and the abbreviation “MEC” in the following document shall be construed to mean MidAmerican Energy Company.

		Technical Requirements for Interconnection of Generation to the MidAmerican Energy Company Distribution System (<i>TRIMECS</i>)	PREFACE
REVISION 1.0	ISSUED 05/01/05		

Section 1: Introduction

- 1.0** MidAmerican Energy Company is dedicated to providing the highest standard of reliable and safe electric service to all of its customers. These standards are reflected in the construction and operation of the MEC electric distribution system.
- 1.1** The components of the electric distribution system are subject to a variety of hazardous conditions, both natural and man-made. MEC installs protective devices at its electric distribution substations to detect these hazardous conditions and take action to minimize the interruption of service to customers as a result of them. These protective devices function properly only if all sources of energy and fault current are taken into consideration. The operation of distributed generation sources in parallel with the MEC electric distribution system may alter the operation of these protective devices because they provide an additional source of energy and fault current that must also be disconnected in the event a hazardous condition occurs on the electric distribution system.
- 1.2** Since the installation and operation of distributed generation in parallel with the MEC electric distribution system can potentially jeopardize the integrity of both systems, it is essential that a suitable protection system be utilized at the distributed generation facility that can detect hazardous conditions and take action to remove the customer generation source. Because MEC seeks to minimize hazards to its personnel and facilities, other MEC customers and the general public, it is in the company's interest to regulate the addition of customer generation. This is accomplished by establishing standards of interconnection that insure a suitable protection system is used at the distributed generation facility. These standards insure that the highest levels of reliability and safety of the electric distribution system are maintained.
- 1.3** MEC derives its authority to establish these requirements through its tariffs and rates, which are submitted and approved by the authorities having jurisdiction over utility service in the states that MEC serves and are binding on both MEC and all its customers. The technical requirements established by the company are in accordance with all state and federal laws.
- 1.4** This document, Technical Requirements for Interconnection of Generation to the MidAmerican Energy Company Distribution System (hereafter referred to by the acronym "**TRIMECS**"), is the administrative and technical manual that specifies MEC's technical requirements and enumerates step-by-step procedures for the interconnection of customer-owned distributed generation facilities to the MEC electric distribution system where MEC's nominal delivery voltage is 15 kV or less.

		Technical Requirements for Interconnection of Generation to the MidAmerican Energy Company Distribution System (TRIMECS)	MAIN
REVISION 1.0	ISSUED 05/01/05		MAIN Page 1 of 18 TRIMECS Page 4 of 46

1.4.1 The goals of this document are as follows:

- (a) Ensure the safety of the general public and MEC personnel.
- (b) Minimize possible damage to the property of the general public, MEC customers, and the MEC electric system.
- (c) Permit the facility owner to install and operate generating equipment in parallel with the MEC electric system in a manner that is safe and reliable.
- (d) Minimize adverse operation conditions on the MEC electric system.
- (e) Provide a consistent standard to insure that all interconnection installations are evaluated fairly and equally.

1.5 MEC reserves the right to revise **TRIMECS** at any time, and withdraw it without notification. MEC may require the facility owner to comply with the requirements in any future revisions to **TRIMECS**. An **applicant** may confirm that the document in his possession is the current revision of **TRIMECS** by contacting his appointed MEC **Energy Consultant (EC)**. If the **applicant** does not have an **EC**, he is instructed to contact either MidAmerican Energy Company's Electric System Planning Department or System Protection Department. Both are part of the Electrical Engineering Department in Davenport, Iowa.

Section 2: Scope

2.0 The requirements stated in **TRIMECS** are applicable to all customer-owned distributed generation facilities interconnected with MEC electrical distribution facilities of 15kV or less, regardless of size, technology, method of transition employed, or desired mode of operation.

2.1 **TRIMECS** is intended to supplement, but not replace, information contained in regulatory codes (such as the Code of Federal Regulations (CFR) and the Iowa Administrative Code (IAC)), MEC electric service tariffs, and specific interconnection agreements. In addition to complying with the requirements of **TRIMECS**, the **facility owner's** installation must comply with all applicable national, state and local construction and safety codes such as the National Electrical Code (NEC) and the National Electrical Safety Code (NESC). The requirements in this document may not cover all details in specific installations.

Section 3: Overview of the **TRIMECS** Approval Process

3.0 The **TRIMECS** approval process consists of three steps: **preliminary approval**, **design approval**, and **final approval**. The following paragraphs describe the approval process in some detail, and are designed to give the **applicant** an idea of what to expect.

		Technical Requirements for Interconnection of Generation to the MidAmerican Energy Company Distribution System (<i>TRIMECS</i>)	MAIN
REVISION 1.0	ISSUED 05/01/05		MAIN Page 2 of 18 TRIMECS Page 5 of 46

3.1 The first step in the approval process is **preliminary approval**. The following events are expected to take place during the preliminary approval stage of the project:

- The process begins with the **applicant** contacting his designated **EC** or other designated MEC representative to discuss the planned interconnection.
- The **applicant** will be provided a current copy of **TRIMECS**, from which he will complete and return to MEC all of the information required in Appendix A: Preliminary Approval Submittal Checklist.
- If necessary, either the EC or other designated MEC representative will arrange planning and engineering meetings as required with the **applicant**, the **applicant's** engineer or other representatives to discuss design of the interface facilities, design standards and studies required.
- **MEC** will then perform an **impact study** to determine requirements and preliminary feasibility of the interconnection. If the **impact study** identifies any problems that will be created as a result of the proposed interconnection, the **applicant** will be notified as to the cost of remedial actions needed to alleviate the problems. Remedial actions may include, but are not limited to, changes or additions to the MEC electric system or the customer's facilities. If additions to MEC's infrastructure are necessary, the **applicant** will be provided with a detailed, written estimate of the work required.
- Upon receipt of the **impact study**, the **applicant** will decide whether or not to continue in the approval process. If the **applicant** opts to continue with the approval process, he must pay the cost of any remedial actions identified in the **impact study**. Payment of these costs must be received prior to the applicant's participation in any MEC sponsored incentive programs (e.g. curtailment).
- The **applicant** will be responsible for the entire actual cost of additions to the MEC electric system. Should the actual cost exceed the estimate, the **applicant** will pay the additional cost. Should the actual cost fall below the estimate, MEC will refund any excess to the **applicant**.
- Upon receipt of payment, MEC will issue a Preliminary Approval Letter that concludes the preliminary approval process.

3.2 The second step in the approval process is **design approval**. The **design approval** stage begins at the completion of the **preliminary approval** stage. The following events are expected to take place during the **design approval** stage of the project:

- The **applicant** will solicit bids for equipment and installation and perform the necessary engineering work to design the interconnection.
- The **applicant** will then submit to MEC all of the information required in Appendix B: Design Approval Submittal Checklist.
- MEC will then review the design to insure that it conforms to the current requirements in **TRIMECS**. This review will include the interconnection

		Technical Requirements for Interconnection of Generation to the MidAmerican Energy Company Distribution System (TRIMECS)	MAIN
REVISION 1.0	ISSUED 05/01/05		MAIN Page 3 of 18 TRIMECS Page 6 of 46

- equipment protection schemes, synchronization schemes, generator protection schemes and the rest of the overall installation. The applicant shall obtain MEC's acceptance of those portions of design documents that apply to the protection and security of the MEC electric distribution system.
- MEC will provide a list of deficiencies of the design in writing to the **applicant**. The **applicant** shall correct the design as necessary and re-submit the appropriate documentation.
- When MEC is satisfied that the design of the proposed interconnection meets the design requirements specified in **TRIMECS**, MEC will issue a Design Approval Letter that concludes the design approval stage.

3.3 The final step in the approval process is **final approval**. The **final approval** stage begins at the completion of the **design approval** stage. The following events are expected to take place during the **final approval** stage of the project:

- The **applicant** will begin construction of the proposed interconnection.
- The **applicant** will then submit to MEC all of the information required in Appendix C: Final Approval Submittal Checklist.
- MEC will then review this information to insure that it conforms to the current requirements in **TRIMECS**.
- MEC will provide a list of deficiencies in writing to the **applicant**. The **applicant** will make corrections as necessary and re-submit the appropriate documentation.
- When MEC is satisfied that all of the submittals provided in the **final approval** stage meet all of the requirements specified in **TRIMECS**, an MEC representative will come to the site to observe the final testing of the installation (witness test). It is the responsibility of the applicant to provide trained personnel and equipment to perform the necessary testing.
- **Final approval** of the new installation is complete upon the issuance of a Final Approval Letter. Upon receipt of **final approval**, the **applicant** (who is now a **facility owner**) may commence operation of the generation equipment in the mode specified. The **facility owner** may also participate in any MEC sponsored incentive programs (e.g., **curtailment**), provided that all other eligibility requirements are met.

Section 4: Specific Interconnection Design Criteria

4.0 The following paragraphs describe the specific interconnection design criteria based upon size (generation capacity), technology, intended use, and method of source transition employed by the interconnected generation that will be used to evaluate all proposed interconnections.

4.1 The following subsections list the factors used in considering the requirements for interconnection. Many of the terms are defined in Appendix D: Definitions and Abbreviations.

		Technical Requirements for Interconnection of Generation to the MidAmerican Energy Company Distribution System (TRIMECS)	MAIN
REVISION 1.0	ISSUED 05/01/05		MAIN Page 4 of 18 TRIMECS Page 7 of 46

4.1.1 Sizes-MEC subdivides distributed generation into the following categories according to size (generation capacity):

- (a) *Small*
- (b) *Medium*
- (c) *Large*

4.1.2 Technologies-MEC subdivides distributed generation into the following categories according to technology:

- (a) *Synchronous Machine*
- (b) *Induction Machine*
- (c) *Self-commutated inverter*
- (d) *Line-commutated inverter*

4.1.3 Transition Modes-MEC subdivides distributed generation into the following categories according to transition modes:

- (a) *Open Transition (or Break-Before-Make)*
- (b) *Momentary Parallel*
- (c) *Extended Parallel*
- (d) *Continuous Parallel*

4.1.4 Intended Uses-MEC subdivides distributed generation into the following categories according to intended use:

- (a) *Emergency (or Backup)*
- (b) *Stand-by*
- (c) *Export*

Section 5: General Requirements for All Interconnections

5.0 The following paragraphs describe the general requirements for ALL interconnections. It is recommended that the **applicant** carefully read this section to insure that the design meets all of the listed requirements. Failure to meet all listed requirements will result in unnecessary delay of the project at the **applicant's** expense.

5.1 Construction of the proposed interconnection is not expected to commence **PRIOR TO THE BEGINNING** of the **final approval** phase of the project. The **applicant** shall solicit approval from MEC **BEFORE** making any significant expenditure for equipment. Design standards of interface will not be compromised due to

		Technical Requirements for Interconnection of Generation to the MidAmerican Energy Company Distribution System (TRIMECS)	MAIN
REVISION 1.0	ISSUED 05/01/05		MAIN Page 5 of 18 TRIMECS Page 8 of 46

applicant's non-compliance with the approval process, lack of communications or other omissions on project activities.

- 5.2 The **applicant** shall obtain MEC's acceptance of those portions of design documents that apply to protection and security of the MEC distribution system. The **applicant** is solely responsible for the design that affects his facility. Protection of the **applicant's** overall electrical system, including generation and connected load, is the sole responsibility of the **applicant**.
- 5.3 If the applicant's generation is connected to the MEC system through a transformer, the winding connection on the MEC side of that transformer shall be a wye configuration. Only in **EXTRAORDINARY** circumstances as determined on a case-by-case basis by MEC, shall an applicant be permitted to connect generation to the MEC system using a transformer with a delta winding connection on the MEC side.
- 5.4 MEC requires a **licensed professional engineer (PE)** whose primary discipline is electrical engineering and who is currently licensed to perform engineering work in the state where the prospective facility is to be installed to certify **ALL** engineering documentation submitted for review. In most cases, state law generally requires that all engineering work be done by or under the direct supervision of a licensed professional engineer. It is the **applicant's** responsibility to secure the services of a qualified engineer. Failure to do so will cause unnecessary delays to the project for which MEC cannot accept responsibility. Use of non-licensed engineering services is prohibited.
- 5.5 Distributed generation **SHALL NOT** be allowed to operate in closed transition on **secondary networks** (i.e. distribution secondary networks), **REGARDLESS** of the duration of parallel operation. Secondary network protectors are not rated and tested for this application. Additional study will be required to determine if generation can operate in closed transition on feeders that supply secondary networks.
- 5.6 Any proposed installation that supplies excessive fault currents to the MEC system, (as determined by MEC personnel through the **impact study**) may be required to include fault limiting equipment as part of its facility design.
- 5.7 The interconnection design shall incorporate standard **basic impulse insulation level (BIL)** ratings for all interconnection equipment. The standard **BIL** for 15kV equipment is 95kV & 110kV.
- 5.8 The interconnection design shall be such that MEC will still be able to ground and test any MEC owned or serviced equipment. This may require the **applicant** to pay for and install approved grounding equipment at the facility.

		Technical Requirements for Interconnection of Generation to the MidAmerican Energy Company Distribution System (TRIMECS)	MAIN
REVISION 1.0	ISSUED 05/01/05		MAIN Page 6 of 18 TRIMECS Page 9 of 46

- 5.9** Some installations may incorporate multiple interconnections to the MEC system. This may involve one or more MEC distribution feeders. The interconnection design shall meet all **TRIMECS** requirements for all possible system configurations.
- 5.10** The interconnection design shall be such that harmonic content of the voltage and current waveforms of both systems shall be within limits defined by IEEE Standard 519.
- 5.10.1** MEC will, at its discretion, monitor the voltage and current waveforms at the **facility owner's** service entrance. Should it be determined that the **facility owner's** equipment is responsible for either voltage or current distortion in excess of that allowed by accepted industry standards, MEC will take all of the following actions:
- (a) The **facility owner** will be notified immediately.
 - (b) Parallel operation of the generation will cease.
 - (c) The **facility owner** will immediately become ineligible to participate in any MEC sponsored incentive programs.
- 5.10.2** Following the actions taken in 5.10.1 above, MEC will require the **facility owner** to correct the harmonic distortion problem. Should the **facility owner** fail to achieve an acceptable solution to the problem, MEC will offer to install harmonic filtering at the facility owner's service entrance. The expense of all associated engineering, purchase; installation and maintenance of such equipment will be borne by the **facility owner**.
- 5.11** The interconnection design shall incorporate adequate facilities to enable the on-site generation to be synchronized with the MEC electric distribution system.
- 5.11.1** The **facility owner** is solely responsible for synchronizing his generator to the MEC electric distribution system. All points at which the generator can be paralleled with the MEC electric distribution system **MUST** be clearly defined as **synchronization points** in the submittal documentation. A given installation may be designed such that there are several **synchronization points**.
- 5.11.2** Every circuit opening or closing device such as circuit breakers or disconnect switches in the circuit path between MEC and the on-site generation shall be either:
- (a) Designated as a **synchronization point** and be equipped with its own dedicated synchronizing equipment **OR**;
 - (b) Electrically or mechanically interlocked with the synchronizing device at the clearly defined **synchronization point** such that the synchronizing

		Technical Requirements for Interconnection of Generation to the MidAmerican Energy Company Distribution System (TRIMECS)	MAIN
REVISION 1.0	ISSUED 05/01/05		MAIN Page 7 of 18 TRIMECS Page 10 of 46

device will be automatically tripped and blocked from closing any time the interlocked circuit opening or closing device is opened.

5.11.3 A separate, independent, single-phase synchronism check relay shall be installed to supervise all manual and automatic synchronizing attempts. The synchronism check relay shall adhere to the following criteria:

- (a) The output of the synchronism check relay must be wired directly in the breaker close path. Wiring the output of the synchronism check relay to supervise the breaker via a **programmable logic controller (PLC)** is prohibited.
- (b) The synchronism check relay shall be set as shown in the table below:

Table 5.11: Synchronizing Device Required Settings

Generator Rating	Slip Frequency Difference Setting (Δf)	Voltage Difference Setting (ΔV)	Phase Angle Difference Setting ($\Delta \Phi$)
<i>(kVA)</i>	<i>Hz</i>	<i>%</i>	<i>degrees</i>
0-500	0.3	10	20
>500-1,500	0.2	5	15
>1500-10,000	0.1	3	10

5.12 The interconnection design shall incorporate adequate interconnection metering facilities.

5.12.1 All metering equipment required will be furnished and maintained by MEC. Metering equipment includes all watt-hour meters, VAR-hour meters, energy recorders, current and potential transformers at each point of interconnection for billing and system control.

5.12.2 MEC will install all watt-hour meters, VAR-hour meters and energy recorders.

		Technical Requirements for Interconnection of Generation to the MidAmerican Energy Company Distribution System (TRIMECS)	MAIN
REVISION 1.0	ISSUED 05/01/05		MAIN Page 8 of 18 TRIMECS Page 11 of 46

- 5.12.3** The **facility owner** shall furnish, install and maintain all meter sockets, cabinets, conduits, wiring and test switches for MEC metering equipment.
- 5.12.4** The **facility owner** shall be responsible for making the primary connections to the instrument transformers.
- 5.12.5** All metering devices shall be either of the detented type or electronic dual register so as to prevent any energy flowing to the MEC system from reducing the meter registration.
- 5.12.6** Consult the MidAmerican Energy Company Electric Service Manual for all specific metering requirements.
- 5.13** The interconnection design shall accommodate automatic reclosing of circuit breakers utilized in MEC's electric system. Reclose delays as short as twenty cycles can be anticipated.
- 5.14** The interconnection design shall specify that all protective devices be equipped with operation indicators (targets) or shall be connected to an annunciator or event recorder so that it will be possible to determine after the fact which devices initiated a particular trip operation.
- 5.15** The interconnection design shall incorporate equipment to detect system abnormalities or disturbances in either the **facility owner's** system or the MEC system. This equipment shall have the capability to isolate the sources of the disturbance.
- 5.16** The interconnection design shall be such that the generator, transformer and other auxiliary equipment shall be protected such that failure of that equipment shall result in the automatic isolation of the affected equipment.
- 5.17** The interconnection design shall be such that if the connection to the MEC supply system is opened for any reason the **facility owner's** generation will not supply power or current to other MEC customers.
- 5.18** The interconnection design shall be such that the facility owner's generation cannot energize MEC owned equipment when the MEC electric distribution system is de-energized.
- 5.19** The interconnection design shall incorporate a disconnect switch that is capable of meeting all of the following criteria:

		Technical Requirements for Interconnection of Generation to the MidAmerican Energy Company Distribution System (TRIMECS)	MAIN
REVISION 1.0	ISSUED 05/01/05		MAIN Page 9 of 18 TRIMECS Page 12 of 46

5.19.1 The disconnect switch shall be able to provide electrical isolation of the **facility owner's** generation from the MEC system.

5.19.2 Any and all three phase generation at the facility owner's facility shall be isolated by a three phase disconnect switch.

5.19.3 The disconnect switch shall be readily accessible and include provisions to allow the mechanism to be padlocked in the open position by either MEC or the **facility owner**.

5.19.4 If the nominal voltage of the on-site generation is above 600 volts, then the disconnect switch shall provide a VISIBLE air opening to comply with MEC safety rules, the National Electrical Safety Code, and the National Electrical Code.

Exception to 5.19.4 For **qualifying facilities**, the disconnect switch must provide a VISIBLE air opening regardless of the nominal voltage level of the on-site generation.

5.19.5 The disconnect switch shall be in addition to the circuit breakers required for normal operation.

Exception to 5.19.4 For some installations as determined by MEC on a case-by-case basis, a breaker that can be removed (racked out) will satisfy the visible disconnect requirement. Note that all **qualifying facilities** MUST have a separate disconnect switch.

5.20 Any interconnection design utilizing single phase generation shall observe a maximum limit of 167 kVA to maintain balanced load on the MEC electric distribution system.

		Technical Requirements for Interconnection of Generation to the MidAmerican Energy Company Distribution System (TRIMECS)	MAIN
REVISION 1.0	ISSUED 05/01/05		MAIN Page 10 of 18 TRIMECS Page 13 of 46

Section 6: Required Equipment Based Upon Size (Generation Capacity)

- 6.0 The following minimum required equipment is necessary for an on-site generator installation qualifying as **small**:
- 6.0.1 If the generator is classified as small, only the voltage and frequency relaying specified in TRIMECS Appendix R, Section AR 1.2 shall be required. The reverse power and instantaneous overcurrent elements specified in TRIMECS Appendix R, Section AR 1.3 & 1.4 are not required.
- 6.0.2 **Small** generators employing **induction machine, self commutated inverter, or line commutated inverter** technology may be exempted from the interconnection protective relay requirements listed in Section 8.2.3 provided they have integrated protection that is equivalent. Inverters must be UL 1741 compliant and induction generators must meet the requirements of IEEE C37.02: Guide for AC Generator Protection.
- 6.0.3 **Small** generators employing **synchronous machine** technology shall not be exempted from the requirements listed in Section 8.2.3.
- 6.1 If the generator installation is excessively large (greater than 4 MW aggregate), MEC may require **SCADA** equipment to be installed per Section 9.1.7.

Section 7: Required Equipment Based Upon Technology

- 7.0 The following minimum required equipment is necessary for an on-site generator that utilizes **synchronous machine** technology:
- 7.0.1 MEC strongly recommends all necessary protection equipment called for in IEEE C37.102: Guide for AC Generator Protection.
- 7.1 The following minimum required equipment is necessary for an on-site generator that utilizes **induction machine** technology:
- 7.1.1 MEC strongly recommends all necessary protection equipment called for in IEEE C37.102: Guide for AC Generator Protection.
- 7.1.2 Line commutated induction generators that require continuous energization by the utility system to operate require only the voltage and frequency relaying specified in TRIMECS Appendix R, Section AR 1.2. The reverse power and instantaneous overcurrent elements specified in TRIMECS Appendix R, Section AR 1.3 & 1.4 are not required.

		Technical Requirements for Interconnection of Generation to the MidAmerican Energy Company Distribution System (TRIMECS)	MAIN
REVISION 1.0	ISSUED 05/01/05		MAIN Page 11 of 18 TRIMECS Page 14 of 46

7.2 The following minimum required equipment is necessary for an on-site generator that utilizes **self commutated inverter** technology:

7.2.1 MEC strongly recommends that all equipment is UL 1741 compliant.

7.3 The following minimum required equipment is necessary for an on-site generator that utilizes **line commutated inverter** technology:

7.3.1 MEC strongly recommends that all equipment is UL 1741 compliant.

Section 8: Required Equipment Based Upon Transition Mode

8.0 The following minimum required equipment is necessary for an on-site generator installation utilizing **open transition transfer mode**:

8.0.1 A transfer switch, capable of meeting all of the following criteria:

- (a) The switch shall be mechanically interlocked such that all phases of the on-site generation source are prevented from paralleling with the utility source (i.e. a “break-before-make” switch) during transfer.
- (b) This switch shall be **readily accessible** to MEC personnel and include provisions to allow the mechanism to be padlocked in the open position by either MEC or the **facility owner**.

8.1 The following minimum required equipment is necessary for an on-site generator installation utilizing **momentary parallel transfer mode**:

8.1.1 A single transfer switch, capable of meeting all of the following criteria:

- (a) The switch shall be capable of completing the transfer from utility source to generation source and vice versa in 100 milliseconds or less.
- (b) The switch shall be incapable of being programmed to complete the transition from utility source to the on-site generation source (i.e. equipment with “soft-load transfer” capability) in a time greater than 100 milliseconds.
- (c) The switch shall be **readily accessible** to MEC personnel and include provisions to allow the mechanism to be padlocked in the open position by either MEC or the **facility owner**.
- (d) The switch shall have a discrete timer that is capable of measuring the 100 millisecond transfer time of the aforementioned switch, complete with logic circuitry such that should the transfer time exceed 100 milliseconds, the parallel condition between the utility source and the on-site generation source will be removed in less than one second from

		Technical Requirements for Interconnection of Generation to the MidAmerican Energy Company Distribution System (TRIMECS)	MAIN
REVISION 1.0	ISSUED 05/01/05		MAIN Page 12 of 18 TRIMECS Page 15 of 46

the initial parallel operation. This timer shall not be a function of a microprocessor based transfer switch controller.

(e) The switch shall conform to all requirements of the UL 1008 standard.

8.2 The following minimum required equipment is necessary for an on-site generator installation utilizing **extended parallel transfer mode**:

8.2.1 A three-phase automatic disconnecting device (normally a circuit breaker) shall be installed at the **facility owner's** facility to connect the on-site three-phase generation to the MEC system.

(a) The three-phase automatic disconnecting device must operate from batteries or other suitable means not requiring AC power.

(b) **Exception:** For almost all cases, MEC shall insist that the three-phase automatic disconnecting device be a circuit breaker. Only in **EXTRAORDINARY** circumstances, as determined on a case-by-case basis by MEC, shall three-phase automatic disconnecting devices other than circuit breakers be considered as acceptable.

8.2.3 Each interconnection point shall have an **interconnection protective relay (IPR)** system acceptable to MEC. The **IPR** system will adhere to the following design criteria:

(a) The **IPR** shall be **utility grade**.

(b) The sensing inputs of the **IPR** will be located such that the **IPR** will be able to monitor the voltage and current at the interconnection point.

(c) The **IPR** will be able to issue trip signals to any and all automatic three-phase disconnect devices to effectively separate the utility source from the on-site generation source should a fault condition be detected. It is preferable to have the **IPR** directly trip the automatic three-phase disconnect devices, however, tripping via approved auxiliary relays (e.g. lockout relay) is acceptable. **IPR** tripping via **PLC** is prohibited.

(d) Refer to Appendix R: Interconnection Protective Relay (IPR) Elements Guide for required IPR protective elements and setting criteria.

(e) The **IPR** voltage sensing inputs will be connected in a wye configuration. Three phase-to-neutral wye-wye grounded potential transformers or direct connection to bus potentials at lower voltages are acceptable. Open delta and delta connected potential transformers shall not be allowed.

(f) The **IPR** design will include test switches that allow all of the AC and DC inputs and outputs of the **IPR** to be isolated for testing purposes. These test switches shall also be configured such that they will allow the injection of secondary voltage and current quantities for testing. ABB Type "FT" test switches are preferred for this purpose.

		Technical Requirements for Interconnection of Generation to the MidAmerican Energy Company Distribution System (TRIMECS)	MAIN
REVISION 1.0	ISSUED 05/01/05		MAIN Page 13 of 18 TRIMECS Page 16 of 46

- (g) The **IPR** shall be designed in such a way that it is able to independently determine when the on-site generation source is in parallel with MEC. Inputs from either the 52a or 52b auxiliary contacts from both the interconnection breaker and the generator output breaker shall be directly hardwired to the **IPR's** inputs for this purpose. Ancillary devices, such as **PLC's** used for the general control and the operation of the generator, shall not be used to provide parallel status to the **IPR**.
- (h) If the **IPR** has sequence of event recording and/or event recording capabilities, these capabilities shall be utilized. Event records and SER logs shall be made available to MEC for analysis.

8.3 The following minimum required equipment is necessary for an on-site generator installation utilizing **continuous parallel transfer mode**:

8.3.1 All of the requirements listed under **TRIMECS** Section 8.2 above.

8.3.2 If the possibility exists for the **facility owner's** generation to become islanded with other MEC customer load AND the **facility owner's** generation capacity is equal to or exceeds 50% of the **minimum feeder load** to which his facility is interconnected, the interconnection design shall be required to install a **direct transfer trip (DTT)** protection system. The **DTT** protection system shall comply with the following criteria:

- (a) The **DTT** protection system equipment shall be **utility grade**.
- (b) The **DTT** signal shall be sent from the MEC substation to each interconnection point at the facility.
- (c) The **DTT** signal shall be implemented through a suitable communications channel approved by MEC.
- (d) Reception of the **DTT** signal shall cause all three-phase automatic disconnect devices to trip sufficient to separate the on-site generation source from the MEC source if the two are in parallel.
- (e) Reception of the **DTT** signal shall prevent the parallel operation of the on-site generation.
- (f) Loss of the **DTT** signal shall be interpreted as a trip, causing actions 8.3.2(c) and 8.3.2(d) above.
- (g) The tripping and lockout of all three-phase automatic disconnect devices shall be either hardwired or done through approved contact multiplier relays, i.e. a lockout relay. Implementation of the **DTT** tripping scheme via **PLC** is prohibited.
- (h) MEC shall be responsible for engineering the **DTT** system at the substation. MEC shall be responsible for engineering the communications medium from the substation to the facility. The **facility owner** shall be responsible for engineering the **DTT** system at the facility.

		Technical Requirements for Interconnection of Generation to the MidAmerican Energy Company Distribution System (TRIMECS)	MAIN
REVISION 1.0	ISSUED 05/01/05		MAIN Page 14 of 18 TRIMECS Page 17 of 46

- (i) The total cost of the **DTT** system including but not limited to: engineering (both for MEC and facility owner), purchase of equipment, installation of equipment at MEC substation and **facility owner's** facility, installation of communications medium, maintenance and testing of such equipment shall be borne by the **facility owner**.

Section 9: Required Equipment Based Upon Intended Use

9.0 There are no additional requirements if the intended use is **emergency** or **stand-by**.

9.1 If the intended use is **export**, the following requirements must be met:

9.1.1 Additional technical, study and contractual requirements apply. **TRIMECS** describes most of the technical requirements, but not all. To address the remaining technical requirements, along with study and contractual requirements, please refer to "Technical Requirements for New Interconnections of Generation to the MEC Electric System". This document is available from the MEC Electric System Planning Department.

9.1.2 If the installation is required to install an **IPR** as specified by **TRIMECS**, the requirement of a reverse power element specified in Appendix R Section AR 1.3 shall be waived.

9.1.3 If the installation is **large** and utilizes **continuous parallel transfer mode**, the interconnection design shall be required to install a **direct transfer trip (DTT)** protection system as described in Section 8.3.2.

9.1.4 If the exporting on-site generator installation qualifies as **medium** the facility shall have **recording metering**, in addition to the normal interconnection metering, that is capable of recording the following values from the generating output:

- (a) MW
- (b) MVAR
- (c) demand
- (d) energy values

9.1.5 The **recording metering** shall include dial up capability.

9.1.6 The **recording metering** shall be capable of storing at least one month of interval data.

		Technical Requirements for Interconnection of Generation to the MidAmerican Energy Company Distribution System (TRIMECS)	MAIN
REVISION 1.0	ISSUED 05/01/05		MAIN Page 15 of 18 TRIMECS Page 18 of 46

9.1.7 If the exporting on-site generator installation qualifies as **large** the installation shall have **SCADA** equipment. This equipment will provide the following data via communications link to the MEC Control Center in Des Moines:

- (a) MW and MVAR quantities measured on the generation output.
- (b) Generator breaker status and switch status for all devices in the electrical interconnection path between the customer's generation and the MEC electric system.
- (c) Control capability of breakers necessary to block the generation from operation in parallel with the MEC electric system. This control capability may include generator output breakers, interconnection breakers, or both.
- (d) Other status and alarm points to be defined and as needed for the reliable and safe operation of MEC electric facilities.

Section 10: Operating Requirements

- 10.0** The operation of the **facility owner's** on-site generation shall not result in unacceptable service to other MEC customers, such as voltage or frequency fluctuations or harmonic current on the MEC system.
- 10.1** The operation of the **facility owner's** on-site generation shall not cause the service voltage for other MEC customers to go outside the requirements of ANSI C84.1, Range A.
- 10.2** The operation of the **facility owner's** on-site generation shall not adversely affect the voltage regulation of the MEC system.
- 10.3** The operation of the **facility owner's** on-site generation shall be conducted in a manner that minimizes reactive flow from the on-site generation to the MEC system, except when requested to assist in voltage control on the MEC system.
- 10.4** The operation of the **facility owner's** on-site synchronous generators shall maintain a power factor range of 0.95 lead to 0.90 lagging, unless otherwise agreed to by MEC and the **facility owner**.
- 10.5** The operation of the **facility owner's** on-site induction machines or other non-synchronous generation shall be required to provide the same VAR support as synchronous machines.
- 10.6** The operation of the **facility owner's** voltage regulation equipment will be designed and operated to limit VAR flow to a power factor between unity and 0.95 lagging.

		Technical Requirements for Interconnection of Generation to the MidAmerican Energy Company Distribution System (TRIMECS)	MAIN
REVISION 1.0	ISSUED 05/01/05		MAIN Page 16 of 18 TRIMECS Page 19 of 46

Section 11: Commission Testing and Maintenance of Interconnection Equipment

11.0 Prior to the final acceptance of the interconnection installation and every maintenance cycle thereafter as specified by the **facility owner** and agreed to by MEC, the interconnection protection system must be tested.

11.1 All testing of the interconnection protection system shall meet the following guidelines:

11.1.1 All testing shall be performed based on written test procedures and shall be formally documented. The written procedures shall be provided by the **facility owner** to MEC no less than 14 business days before initial synchronization and must be approved by MEC prior to the performance of the actual testing.

11.1.2 All tests shall be performed by qualified personnel as agreed to by MEC.

11.1.3 All test results shall be immediately recorded following each individual test. Test results that are recorded following the completion of the entire test sequence will not be accepted.

11.1.4 All test results shall be certified as being correct by qualified personnel.

11.2 Commission testing shall occur prior to the first parallel operation of the interconnection equipment and will consist of three types of tests as described below:

11.2.1 Discrete Element Tests: *IPR* and synchronization devices shall have the set points and time delays of the discrete relay elements tested to determine if they comply with **TRIMECS** requirements.

- (a) Set points for all protective elements shall be tested and shall be within $\pm 5\%$ of setting.
- (b) Time delays for all protective elements shall be tested and shall be within $\pm 10\%$ of setting. Test quantities will be either 80% or 120% of setting for timing tests.
- (c) All synchronization devices shall have the set points listed in Table 5.10 verified. Additionally, if the synchronization device incorporates a “healthy voltage window” scheme, the set points on the over and under voltage elements for this scheme shall be verified. All set points shall meet the tolerance specified in (a) above. Any time delays will be verified as well and shall meet the tolerance specified in (b) above.

		Technical Requirements for Interconnection of Generation to the MidAmerican Energy Company Distribution System (TRIMECS)	MAIN
REVISION 1.0	ISSUED 05/01/05		MAIN Page 17 of 18 TRIMECS Page 20 of 46

- (d) The results of these tests shall be documented using the *IPR* Discrete Relay Element Test Form and the Synchronization Device Discrete Relay Element Test Form in **TRIMECS** Appendix T.

11.2.2 Functional Logic Test: *IPR* and synchronization devices shall have their functional logic tested to determine if they comply with **TRIMECS** requirements.

- (a) The ability of the *IPR* to trip the appropriate breaker (either the generator breaker or the interconnection breaker) under all operating configurations in response to a simulated fault condition shall be verified. If the *IPR* trips the appropriate breaker via an approved auxiliary relay, the ability of that relay to trip the appropriate breaker upon reception of the trip input from the *IPR* shall be verified. The trip path from each individual relay shall be verified where single function relays are used.
- (b) The ability of all lockout relays to prevent closure of the appropriate breaker shall be verified.
- (c) The ability of all synchronization devices to supervise closure of the appropriate breaker shall be verified. The ability of all synchronization devices to prevent closure under abnormal conditions shall also be verified.
- (d) Reverse power functions shall be tested at the installation. This may be tested by injecting test currents and voltages or by increasing the generator output to cause tripping.

11.2.3 Operational Test: The interconnection installation as a whole shall be tested to determine if the system works as intended.

- (a) The parallel operation of the on-site generation will be demonstrated.
- (b) Any specialized control logic that is designed to affect the generator system under abnormal conditions shall be demonstrated.

11.3 Maintenance testing of the interconnection protective relay system shall occur according to the maintenance cycle as specified by the **facility owner** and agreed to by MEC. Maintenance testing shall consist of all of the tests listed under **11.2.1** & **11.2.2** above. This testing shall be documented, retained and be made available upon request to MEC, by the **facility owner**.

		Technical Requirements for Interconnection of Generation to the MidAmerican Energy Company Distribution System (<i>TRIMECS</i>)	MAIN
REVISION 1.0	ISSUED 05/01/05		MAIN Page 18 of 18 TRIMECS Page 21 of 46

Appendix A: Preliminary Approval Submittal Checklist

AA1.0: The following items, that is, **AA1.1** through **AA1.4** and all items listed under them, need to be submitted by the **applicant** to the designated MEC representative in order to be considered for preliminary approval. For details and explanation of the material required refer to the rest of this document, Technical Requirements for Interconnection of Generation to the MidAmerican Energy Company Distribution System (also known as "TRIMECS"). All sections and appendices referenced below are part of this document.

AA1.1: APPLICANT CONTACT FORM: (See Appendix F for blank Contact Forms.) This form provides the information about the **applicant** and the location of the proposed interconnection.

AA1.2: ONE-LINE DIAGRAM: The one-line diagram shall be a single engineering drawing that shows the schematic one-line representation of the proposed facility. All of the following equipment shall be shown (if applicable to the installation):

Item 1: GENERATOR: All of the following items shall be noted on the drawing:

- (a) The rated voltage, kW, kVA and power factor of the generator.
- (b) The winding configuration of the generator and the configuration of the generator neutral.
- (c) The value of any neutral grounding impedance used.
- (d) The kVA rating, turns ratio, and winding configuration of any grounding transformer used on the neutral of the generator.

Item 2: GENERATOR STEP-UP TRANSFORMER (GSU): All of the following items shall be noted on the drawing:

- (a) The transformer kVA rating(s).
- (b) The primary and secondary voltages.
- (c) The percent impedance specified at the transformer base rating.
- (d) The winding configuration of the primary and secondary windings.
- (e) The value of no-load taps (if any).

Item 3: UTILITY TRANSFORMER: All of the following items shall be noted on the drawing: (Note that most of this information can be provided from either the customer's designated **Energy Consultant**, or the local MEC Distribution Engineering/Operations group.)

		Technical Requirements for Interconnection of Generation to the MidAmerican Energy Company Distribution System (TRIMECS)	APPENDIX A	
REVISION 1.0	ISSUED 05/01/05		Appendix A Page 1 of 3 TRIMECS Page 22 of 46	

Appendix A: Preliminary Approval Submittal Checklist

- (a) The transformer kVA rating(s).
- (b) The primary and secondary voltages.
- (c) The percent impedance specified at the transformer base rating.
- (d) The winding configuration of the primary and secondary windings.

Item 4: INTERCONNECTION BREAKER: All of the following items shall be noted on the drawing:

- (a) The continuous current rating.
- (b) The interrupting current rating for both symmetrical and asymmetrical faults.

Item 5: GENERATOR OUTPUT BREAKER: All of the following items shall be noted on the drawing:

- (a) The continuous current rating.
- (b) The interrupting current rating for both symmetrical and asymmetrical faults.

Item 6: AUTOMATIC TRANSFER SWITCH: All of the following items shall be noted on the drawing:

- (a) The continuous current rating.
- (b) The interrupting current rating for both symmetrical and asymmetrical faults.
- (c) The time of transfer for the switch.

Item 7: REVENUE METERING: All of the following items shall be noted on the drawing:

- (a) Present or proposed location of MEC revenue metering.

Note 1: Generally, it is not necessary to include a detailed schematic of the loads at the facility, i.e. 480V and below switchboards, unless the loads can be connected in such a way as to create additional interconnection issues. A simple arrow representing the connection of facility load in relation to the bus tying together the utility source with the on-site generation source is usually sufficient.

AA1.3: EQUIPMENT DATA FOR THE PROPOSED INTERCONNECTION:

Documentation should be submitted to support all of the information supplied for Items 1-7 from Section AA1.2 above. Documentation can be in the form of specifications sheets, test data, other equipment specific technical information, etc. The **applicant** should insure that the submitted documentation specifically includes the following items:

		Technical Requirements for Interconnection of Generation to the MidAmerican Energy Company Distribution System (TRIMECS)	APPENDIX A	
REVISION 1.0	ISSUED 05/01/05		Appendix A Page 2 of 3 TRIMECS Page 23 of 46	

Appendix A: Preliminary Approval Submittal Checklist

Item 1: GENERATOR: Documentation of the following generator impedance data based upon the machine base rating shall be provided: The synchronous, transient and sub-transient reactances of the generator shall be noted on the diagram.

- (a) The synchronous reactance, (X_d).
- (b) The transient reactance, (X'_d).
- (c) The sub-transient reactance, (X''_d).
- (d) The value of any grounding resistor, along with the grounding method.

Item 2: AUTOMATIC TRANSFER SWITCH (ATS): Documentation shall be provided to determine all of the following:

- (a) The method(s) of transition employed by the **ATS** as defined in **TRIMECS** Section 4.1.3.
- (b) The maximum transfer time of the **ATS** for each method of transition, and documentation of any fail-safe capabilities built into the **ATS** that are designed to actuate upon the exceeding of the maximum transfer time.
- (c) The programmability capabilities of the **ATS** for switching between transition methods.

AA1.4: TENTATIVE CONSTRUCTION SCHEDULE FOR THE PROPOSED INTERCONNECTION: This document should list the significant project milestones and the scheduled date for initiation of parallel operation. Notation should be made indicating any deadlines that require MEC approvals.

AA1.5: SITE LAYOUT DRAWING: This document should provide an overview of the interconnection facility to allow MEC personnel to locate the generator and its isolation equipment.

		Technical Requirements for Interconnection of Generation to the MidAmerican Energy Company Distribution System (<i>TRIMECS</i>)	APPENDIX A
REVISION 1.0	ISSUED 05/01/05		Appendix A Page 3 of 3 TRIMECS Page 24 of 46

Appendix B: Design Approval Submittal Checklist

AB1.0: The following items, that is, AB1.1 through AB1.9 and all sub-items listed under them, need to be submitted by the **applicant** to the designated MEC representative in order to be considered for design approval. For details and explanation of the material required refer to the rest of this document, Technical Requirements for Interconnection of Generation to the MidAmerican Energy Company Distribution System (also known as "TRIMECS"). All sections and appendices referenced below are part of this document.

Note 1: Under no circumstances should these items be submitted less than sixty (60) days prior to the scheduled date for initiation of the first parallel operation and testing.

AB1.1: CONTACT FORMS (See Appendix F for blank Contact Forms.) The **applicant** must provide a Contact Form for each and every contractor who will be assuming an area of responsibility in the project. AT A MINIMUM, the **applicant** must provide Contact Forms for the following areas:

1. The consulting engineer responsible for the design of the facility.
2. The engineer responsible for project management for the installation.
3. The consulting engineer responsible for providing relay settings.
4. The electrical contractor responsible for the physical installation of the equipment.
5. Any and all manufacturers who are contributing a significant and specific piece of equipment to the installation. Examples of "significant and specific equipment" would include the generator, switchgear and breakers, ATS, and relay manufacturers.
6. The testing contractor responsible for testing the interconnection protective relay.

AB1.2: DESIGNATION OF SINGLE-POINT-OF-CONTACT (SPC): The **applicant** must designate one individual from the Contact Forms submitted in Section AB1.1 above as the **SPC** for the project. This individual will assume responsibility for communication with MEC personnel throughout the approval process and assure that all the technical requirements are adhered to.

AB1.3: FUNCTIONAL ONE-LINE DIAGRAM: The functional one-line diagram shall be a single engineering drawing that shows the schematic one-line representation of the proposed facility. All of the equipment listed under Appendix A, Section AA1.2 shall be shown. In addition, the following equipment shall also be shown (if applicable to the installation):

		Technical Requirements for Interconnection of Generation to the MidAmerican Energy Company Distribution System (TRIMECS)	APPENDIX B	
REVISION 1.0	ISSUED 05/01/05		Appendix B Page 1 of 4 TRIMECS Page 25 of 46	

Appendix B: Design Approval Submittal Checklist

Item 1: GENERATOR AND INTERCONNECTION PROTECTIVE RELAYING:

All of the following items shall be noted on the drawing:

- (a) Each functional element of the protective relay scheme shall be shown with a circle inscribed with its IEEE device function number. Lockout relays shall be shown with a circle inscribed with the number "86".
- (b) All current and potential instrument transformer inputs of the protective relaying shall be shown in single-line format, and shall be connected to the functional element circle it is serving with a solid line.
- (c) The current and potential transformation ratios, along with polarity markings and secondary connection configuration, of all instrument transformers serving the protective relaying shall be specified.
- (d) Breakers that the protective relaying trips either directly or indirectly through a lockout relay shall be indicated with a DASHED line.
- (e) Breakers for which the protective relaying provides supervisory synchronism checks shall be indicated with a DOTTED line.

Item 2: INTERLOCKS: Interlocks that inhibit the closing or opening of breakers at the installation shall be shown.

Note 1: Generally, it is not necessary to include a detailed schematic of the loads at the facility, i.e. 480V and below switchboards, unless the loads can be connected in such a way as to create additional interconnection issues. A simple arrow representing the connection of facility load in relation to the bus tying together the utility source with the **facility owner's** generation source is usually sufficient.

AB1.4: AC SCHEMATIC DIAGRAM(S): The AC Schematic Diagram(s) shall show the schematic three-phase representation of all of the items and sub-items listed under Appendix A, Section AA1.2 and Section AB1.3 above. (Refer to Appendix E for an example AC Schematic Diagram.) The following items must also be included:

Item 1: GENERATOR PROTECTIVE RELAYING: All of the following items shall be noted on the drawing:

- (a) All current and potential inputs of the generator protective relaying shall be shown connected to the appropriate relay terminal.
- (b) The current and potential transformation ratios, along with polarity markings and secondary connection configuration, of all instrument transformers serving the generator protective relaying shall be specified.

Item 2: INTERCONNECTION PROTECTIVE RELAYING: All of the following shall be noted on the drawing:

		Technical Requirements for Interconnection of Generation to the MidAmerican Energy Company Distribution System (TRIMECS)	APPENDIX B	
REVISION 1.0	ISSUED 05/01/05		Appendix B Page 2 of 4 TRIMECS Page 26 of 46	

Appendix B: Design Approval Submittal Checklist

- (a) All current and potential inputs of the interconnection protective relaying shall be shown connected to the appropriate relay terminal.
- (b) The current and potential transformation ratios, along with polarity markings and secondary connection configuration, of all instrument transformers serving the interconnection protective relaying shall be specified.

Note 1: Individual relay element functions DO NOT have to be denoted in the AC Schematic Diagram.

AB1.5: DC SCHEMATIC DIAGRAM(S) (A.K.A. CONTROL SCHEMATIC DIAGRAM):

The DC Schematic Diagram(s) shall show the DC control logic all of the items and sub-items listed under Appendix A, Section AA1.2 and Section AB1.3 above. (Refer to Appendix E for an example DC Schematic Diagram.) The following items must also be included:

Item 1: GENERATOR AND INTERCONNECTION PROTECTIVE RELAYING:

All of the following items shall be noted on the drawing:

- (a) All relay and control equipment input and output contacts.

Item 2: INTERCONNECTION, GENERATOR OUTPUT, AND ALL BREAKERS CAPABLE OF SYNCHRONIZING: All of the following shall be noted on the drawing:

- (a) Each breaker's respective trip and close circuits.

AB1.6: WIRING DIAGRAM(S): The Wiring Diagram(s) shall show the physical representation of all of the wiring connections for all of the items and sub-items listed under Appendix A, Section AA1.2 and Section AB1.3 above. (Refer to Appendix E for an example Wiring Diagram.)

AB1.7: INTERCONNECTION PROTECTIVE RELAY SETTINGS: A document containing every relay setting parameter for the interconnection relaying shall be submitted to MEC. All of the relay settings shall be included in the submittal, not just the relay protective element set-points and time delays. These settings shall be submitted in a format that can be easily reviewed by MEC. Examples of acceptable formats include vendor software (with prior approval), Microsoft Word or generic text documents, or Microsoft Excel spreadsheets. The submittal shall be accompanied by a signed and sealed document from the licensed professional engineer who determined the settings.

		Technical Requirements for Interconnection of Generation to the MidAmerican Energy Company Distribution System (TRIMECS)	APPENDIX B	
REVISION 1.0	ISSUED 05/01/05		Appendix B Page 3 of 4 TRIMECS Page 27 of 46	

Appendix B: Design Approval Submittal Checklist

AB1.8: INTERCONNECTION PROTECTIVE RELAY TEST PLAN: A document shall be submitted detailing the functional testing to be performed and witnessed by MEC personnel to commission the installation.

AB1.9: REVISED PROJECT SCHEDULE FOR THE PROPOSED FACILITY: This document should list the significant project milestones and the scheduled date for initiation of parallel operation. Notation should be made indicating any deadlines that require MEC approvals.

		Technical Requirements for Interconnection of Generation to the MidAmerican Energy Company Distribution System (TRIMECS)	APPENDIX B
REVISION 1.0	ISSUED 05/01/05		

Appendix C: Final Approval Submittal Checklist

AC1.0: The following items, that is, AC1.1 through AC1.5 and all sub-items listed under them, need to be submitted by the **applicant** to the designated MEC representative in order to be considered for final approval. For details and explanation of the material required refer to the rest of this document, Technical Requirements for Interconnection of Generation to the MidAmerican Energy Company Distribution System (also known as "TRIMECS"). All sections and appendices referenced below are part of this document.

Note 1: Under no circumstances should these items be submitted less than thirty (30) days prior to the scheduled date for initiation of parallel operation.

AC1.1: INTERCONNECTION PROTECTIVE RELAY TEST RESULTS: Completed Appendix T, "Interconnection Protective Relay Discrete Test Sheet" and Appendix T, "Synchronism Relay Discrete Test Sheet" test sheets shall be submitted.

AC1.2: FINAL INTERCONNECTION PROTECTIVE RELAY FINAL SETTINGS: For microprocessor based relays, a copy of the complete settings, in electronic form, downloaded from the relay. This will avoid typing or transcription problems.

AC1.3 FINAL DRAWINGS: If any changes are made to any of the drawings submitted during either the **Preliminary Approval** Stage or the **Design Approval** Stage, these changes must be submitted and approved by the MEC representative at least thirty (30) days prior to final witness testing of the installation. The drawings submitted for final approval shall represent the final configuration of the interconnection installation, including any and all field revisions made during installation and commissioning, and shall be specific and unique to the installation. In other words, shop drawings or generic drawings are not adequate at this point. The required information on these drawings shall be the same as that required in Appendix A and Appendix B.

AC1.4: MAINTENANCE SCHEDULE: The **applicant** will submit a schedule for the future maintenance and operational testing of the interconnection and generator protective relaying.

AC1.5: WITNESS TEST TENTATIVE DATE: The **applicant** will submit a suggested date to schedule witness testing. This date will have to be approved by the MEC representative.

		Technical Requirements for Interconnection of Generation to the MidAmerican Energy Company Distribution System (TRIMECS)	APPENDIX C
REVISION 1.0	ISSUED 05/01/05		Appendix C Page 1 of 1 TRIMECS Page 29 of 46

Appendix D: Definition of Terms and Abbreviations Used in TRIMECS

Appendix D: Definition of Terms and Abbreviations Used in TRIMECS

ALL ENTRIES ARE LISTED IN ALPHABETICAL ORDER.

Applicant: A party who is interested in establishing a distributed generation interconnection with MidAmerican Energy Company. The term **applicant**, where applied, is intended to indicate that the party establishing the distributed generation interconnection has not yet completed the approval process. See also **facility owner**.

Basic Impulse Insulation Level (BIL): A measure of the strength of insulation against a standard 1.5 X 40 μ s wave with a stated crest magnitude in kV.

Continuous Parallel: A **TRIMECS** transition mode category. Generation utilizing this transition mode is characterized by a continuous parallel condition being maintained between the utility source and the on-site generation source. At no time is the on-site generation source and load islanded from the utility source. This transition mode is usually employed by facilities that intend to export power to the utility.

Design Approval: The second step/stage in the MidAmerican Energy Company approval process for establishing interconnections with the utility in which the applicant's design of the facility is evaluated against certain engineering criteria.

Direct Transfer Trip (DTT): A protective relay system that isolates the on-site generation source from the utility source in response to a trip signal provided from a remote location via a suitable communications channel.

Energy Consultant (EC): Many large customers have been assigned an **EC** to specifically manage their account. The **EC** acts as the interface between the company and the customer. Customers that do not have an **EC** may work with another MEC designated representative, e.g. a distribution engineering engineer or technician.

Emergency (or Backup): A **TRIMECS** intended use category that indicates that the **facility owner** intends to operate the generation solely to supply his own on-site load following the failure of the utility source. The **facility owner** does not operate the generation at any other time, with the exception of routine testing of the on-site generation. For example, a hospital that is required to provide on-site emergency generation for the sole use of supporting life safety systems would fall into this category.

Export: A **TRIMECS** intended use category that indicates that the **facility owner** intends to operate the generation at will under any circumstances that he deems favorable, regardless of the status of the utility source **AND** intends to export some or all of the generator's output to MEC.

		Technical Requirements for Interconnection of Generation to the MidAmerican Energy Company Distribution System (<i>TRIMECS</i>)	APPENDIX D
REVISION 1.0	ISSUED 05/01/05		

Appendix D: Definition of Terms and Abbreviations Used in TRIMECS

Extended Parallel: A **TRIMECS** transition mode category. Generation utilizing this transition mode is characterized by a transition between the utility source and on-site generation in a time greater than 100 milliseconds, but something less than **continuous parallel** (usually a few minutes). This transition mode is usually implemented through a “soft load transfer” switch. See also **Continuous Parallel**.

Facility Owner: A party who owns and operates on-site distributed generation interconnection that has been approved by MidAmerican Energy Company as called for in this document.

Final Approval: The last step/stage in the MidAmerican Energy Company approval process for establishing interconnections with the utility in which the applicant tests and demonstrates the capabilities of his equipment and receives final MEC permission to operate his equipment in parallel with the utility.

Impact Study: An engineering study that is performed by MidAmerican Energy Company to determine the feasibility of the interconnection and the special technical requirements with which the installation must comply. This study will usually identify equipment that needs to be provided or upgraded on the MEC System in order to accommodate the applicant’s new interconnection along with estimates for the cost of that equipment.

Induction Machine: A machine that can operate as a generator or motor and operates at slightly higher than synchronous speed. Generators of this type are characterized by their need to have an external source of VARs for excitation, and are usually driven by a prime mover.

Intended Use: A **TRIMECS** category that allows the facility owner to specify under what conditions he intends to operate the on-site generation.

Interconnection Protective Relay (IPR): A **utility grade** protective relay that has all of the protective elements described in TRIMECS Appendix R: Interconnection Protective Relay (IPR) Elements Guide, which is used to isolate the on-site distributed generation from the MEC utility source when the two are operating in parallel and an abnormal condition occurs either at the on-site distributed generation facility or on the utility feeder.

Large (as applied to generator size): large sized units are defined as the maximum unit rated aggregate capability meeting **ANY** of the following criteria:

1. Exceeds 2000 kVA total.
2. Exceeds 25% of the maximum available system fault current at the point of common coupling.
3. Exceeds 80% of the minimum feeder loa

		Technical Requirements for Interconnection of Generation to the MidAmerican Energy Company Distribution System (TRIMECS)	APPENDIX D
REVISION 1.0	ISSUED 05/01/05		Appendix D Page 2 of 5 TRIMECS Page 31 of 46

Appendix D: Definition of Terms and Abbreviations Used in TRIMECS

Licensed Professional Engineer or PE: An individual who has attained a license to practice engineering from a state review board. MEC requires a **PE** to certify all engineering documentation that is submitted by an **applicant** for review.

Line-Commutated Inverter: A solid-state device that utilizes power electronics to reconstruct a 60Hz sine wave for power generation. Devices of this type are characterized by their need to have an external 60 Hz sine wave to allow the unit to generate power and are usually used to convert the DC output from photovoltaic and fuel cells into AC.

Medium (as applied to generator size): Medium sized units are defined as the maximum unit rated aggregate capability meeting all of the following criteria:

1. Exceeds 500 kVA total.
2. Exceeds 10% but does not exceed 25% of the maximum available system fault current at the point of common coupling.
3. Exceeds 20% but does not exceed 80% of the minimum feeder load.

Minimum Feeder Load: The minimum expected load on a distribution circuit, including the **facility owner's** load.

Momentary Parallel: A **TRIMECS** transition mode category. Generation utilizing this transition mode will initiate a complete transfer between the utility source and the on-site generation source in 100 milliseconds or less. Facilities utilizing equipment that employs this transition mode may experience a "blink" condition when switching from the utility source to the on-site distributed generation source.

EXCEPTION: Equipment that can be programmed to complete the transition between utility source and the on-site generation source (i.e. equipment with "soft-load transfer" capability) in a time greater than 100 milliseconds shall not qualify as **momentary parallel** transition mode status.

Open Transition (or Break-Before-Make): A **TRIMECS** transition mode category. Equipment using this type of transition is designed such that the on-site generation source may never operate in parallel with the utility source. This transition mode is usually implemented through a mechanically interlocked switch. Facilities utilizing equipment that employs this transition mode will experience a "blackout" condition when switching from the utility source to the on-site distributed generation source and vice-versa.

Preliminary Approval: the first step/stage in the MidAmerican Energy Company approval process for establishing interconnections with the utility in which the applicant typically indicates his desire to interconnect.

Programmable Logic Controller or PLC: A solid state control system with programming capability that performs functions similar to a relay logic system. These

		Technical Requirements for Interconnection of Generation to the MidAmerican Energy Company Distribution System (TRIMECS)	APPENDIX D
REVISION 1.0	ISSUED 05/01/05		Appendix D Page 3 of 5 TRIMECS Page 32 of 46

Appendix D: Definition of Terms and Abbreviations Used in TRIMECS

are often used for generator control. MEC does not allow **PLC**'s to be used as inputs to, or components of, the interconnection protective relay (**IPR**) system on distributed generation.

Qualifying Facility: A qualifying facility (also known as QF) is one that qualifies under United States Department of Energy requirements as either a co-generation or renewable fuel facility. Generally, these facilities are designed to export power. A facility that employs wind turbine generation could be a qualifying facility. A facility that employs a diesel generator would not be considered a qualifying facility. Qualifying facilities in Iowa are subject to the Iowa Administrative Code.

Readily Accessible: This term describes equipment located at the **facility owner's** facility that can be accessed by MEC personnel 24 hours a day and 365 days a year. The **facility owner** must provide MEC a 24/365 contact that can provide access if the on-site distributed generation equipment is not readily accessible.

Recording Metering: Devices that measure integrated interval demand and energy load data and store data in a format that can be accessed by utility personnel.

SCADA: An acronym for "Supervisory Control and Data Acquisition". SCADA is "real time" measurement of quantities. This system gives MEC the ability to control several remote substations from a single location.

Self-Commutated Inverter: A solid-state device that utilizes power electronics to reconstruct a 60Hz sine wave for power generation. Devices of this type are characterized by their ability to provide their own excitation and are usually used to convert the DC output from photovoltaic and fuel cells into AC. **Secondary Networks:** A low voltage system (typically 120-208 volts or 277-480 volts) that is normally served from multiple parallel transformers such that no single contingency causes loss of service to the secondary network.

Small (as applied to generator size): Single generating unit rated at 100 kVA or less, OR multiple units rated at 100 kVA or less at a single location with total maximum aggregate capability meeting all of the following criteria:

1. Does not exceed 500 kVA total.
2. Does not exceed 10% of the maximum available system fault current at the point of common coupling. (A unit with a large or low impedance ground source could dilute the fault current from the utility substation and compromise the utility ground fault detection.)
3. Does not exceed 20% of the feeder minimum load. (A unit rated greater than 20% of the minimum load could cause voltage regulation problems on the feeder if the substation Load Tap Changer uses Load Drop Compensation (LDC) or the unit is down stream of a regulator using LDC.)



REVISION
1.0

ISSUED
05/01/05

Technical Requirements for
Interconnection of Generation to the
MidAmerican Energy Company
Distribution System (*TRIMECS*)

APPENDIX D

Appendix D Page 4 of 5

TRIMECS Page 33 of 46

Appendix D: Definition of Terms and Abbreviations Used in TRIMECS

Single-Point-of-Contact (SPC): An individual on the *applicant's* project team that is designated by the *applicant* to be responsible for communication with MEC personnel throughout the approval process. This individual assumes the responsibility to insure that all MEC technical requirements are adhered to throughout the project cycle.

Stand-by: A *TRIMECS* intended use category that indicates that the *facility owner* can operate the on-site distributed generation solely to supply his own on-site load at will, regardless of the status of the utility source. For example, an *facility owner* who elects to participate in an MEC sponsored incentive program may operate on-site generation in response to an order from MEC to curtail his load.

Synchronous Machine: A machine that can operate as a generator or motor and operates at a constant speed and frequency under steady state operation. Generators of this type are characterized by their ability to provide their own excitation, and are usually driven by a prime mover such as a diesel engine.

Synchronization Point: A point at which the on-site generation can be paralleled with the MEC electric distribution system.

TRIMECS: abbreviation that stands for the title of this document, Technical Requirements for Interconnection of Distributed Generation to the MidAmerican Energy Company Electric Distribution System.

Utility Grade: An adjective, usually applied to protective relays that meet all of the criteria established in the following standards:

1. IEEE Std C37.90 IEEE Standard for Relays and Relay Systems Associated with Electric Power Apparatus
2. IEEE Std C37.90.1 IEEE Standard Surge Withstand Capability (SWC) Test for Relays and Relay Systems Associated with Electric Power Apparatus
3. IEEE Std C37.90.2 Standard for Withstand Capability of Relay Systems to Radiated Electromagnetic Interference from Transceivers
4. IEEE Std C37.90.3 IEEE Standard Electrostatic Discharge Tests for Protective Relays

MEC has the right to refuse any protective relay that meets the above standards, but still is not widely recognized as a "*utility grade*" relay by the utility industry.

		Technical Requirements for Interconnection of Generation to the MidAmerican Energy Company Distribution System (<i>TRIMECS</i>)	APPENDIX D
REVISION 1.0	ISSUED 05/01/05		Appendix D Page 5 of 5 TRIMECS Page 34 of 46

Appendix E: Example Drawings

See the attached drawings E1-E11 for examples of the type of engineering drawings that will be required for submittals.

		Technical Requirements for Interconnection of Generation to the MidAmerican Energy Company Distribution System (<i>TRIMECS</i>)	APPENDIX E
REVISION 1.0	ISSUED 05/01/05		

GENERAL LEGEND	
52CS	CIRCUIT BREAKER CONTROL SWITCH
CT	CURRENT TRANSFORMER
MR	MULTI RATIO
SR	SINGLE RATIO
PT	POTENTIAL TRANSFORMER
11	MULTIFUNCTION RELAY
TS	TEST SWITCH
LBS	LOAD BREAK SWITCH
VCB	VACUUM CIRCUIT BREAKER
CPT	CONTROL POWER TRANSFORMER
□	DEVICE TERMINAL ON EXTERNAL EQUIPMENT
○	DEVICE TERMINAL IN SWITCHGEAR
◇	TERMINAL BLOCK ON EXTERNAL EQUIPMENT
◇	TERMINAL BLOCK IN SWITCHGEAR
○	TERMINAL BLOCK IN SUPV
○	BILL OF MATERIAL ITEM NUMBER
NOTES	
REFERENCE DRAWINGS	

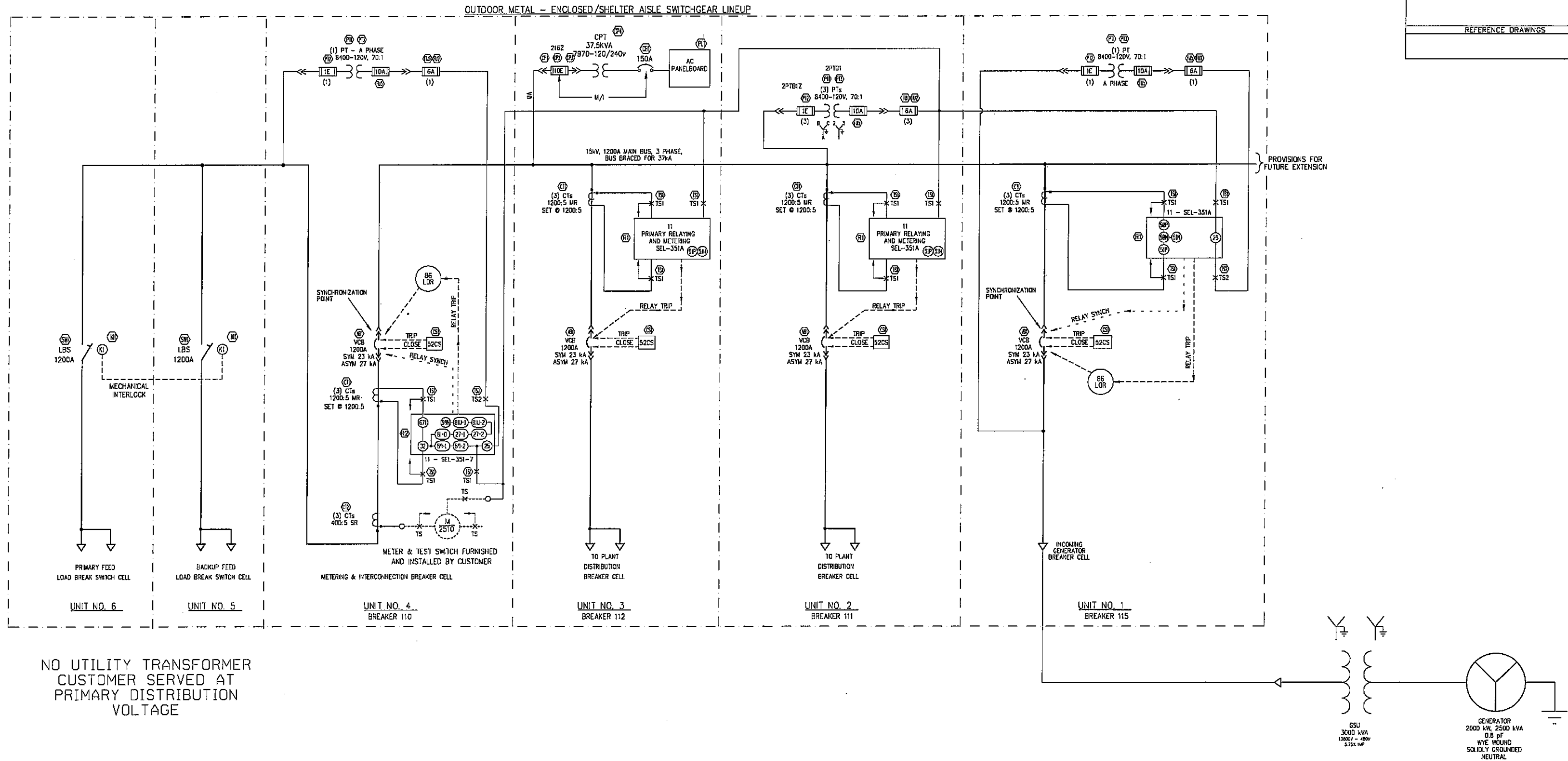

ORIG: 22X34.DGN 05-03-99

REV	DATE	DFTR	APP	DESCRIPTION
08	-	-	-	-
07	-	-	-	-
06	-	-	-	-
05	-	-	-	-
04	-	-	-	-
03	-	-	-	-
02	-	-	-	-
01	05-01-2005	CEM	GKS	ORIGINAL ISSUE

REV	DATE	DFTR	APP	DESCRIPTION

 DATE: 2/22/05
 DESIGNED: GKS
 DRAWN: SAG
 APPROVED: GKS

ABC CORPORATION
 CITY, STATE
FUNCTIONAL ONE LINE DIAGRAM

DWG NO
E1

SCALE:

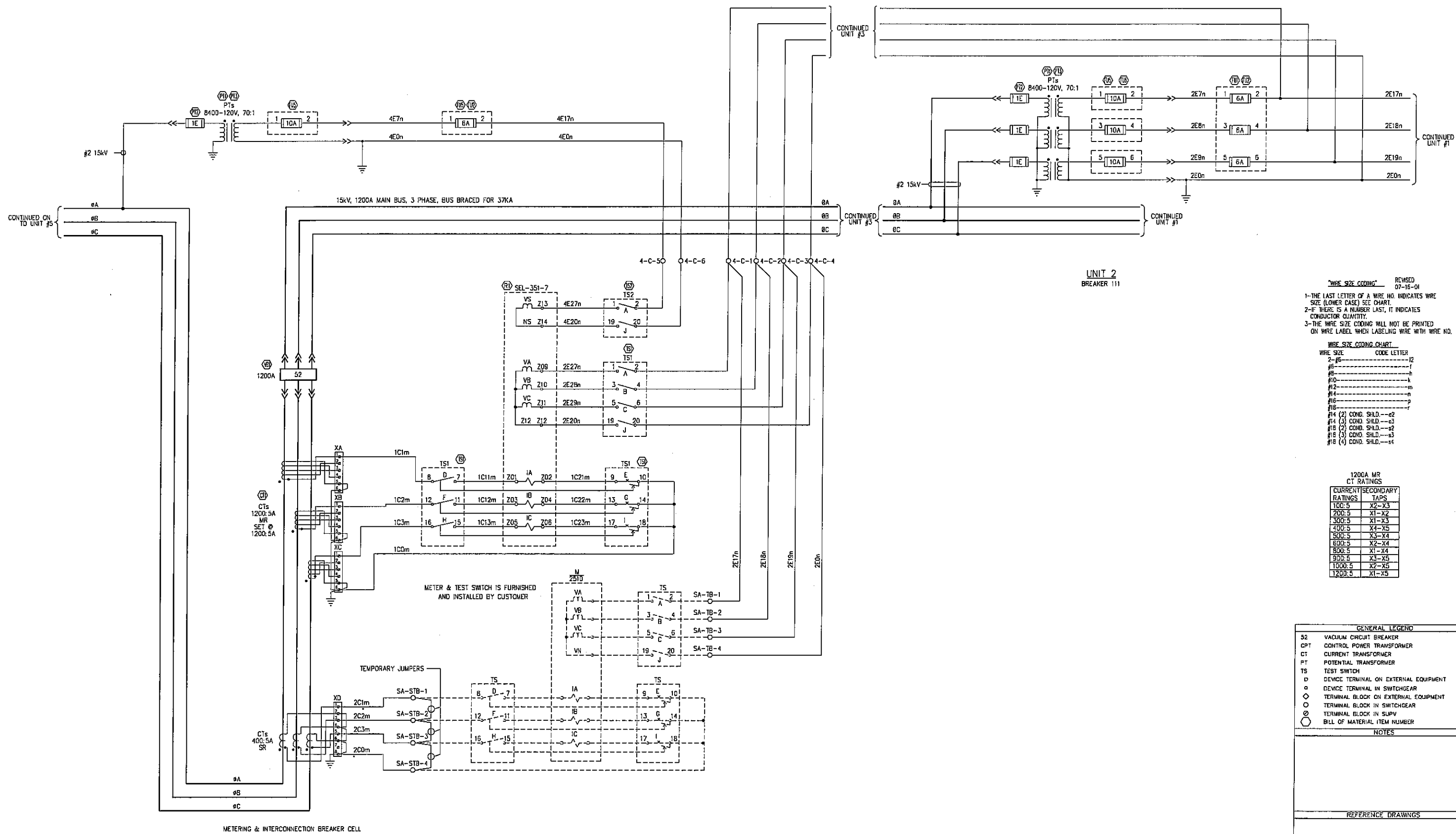

"WIRE SIZE CODING" REWSD 07-16-01
 1-THE LAST LETTER OF A WIRE NO. INDICATES WIRE SIZE (LOWER CASE) SEE CHART.
 2-IF THERE IS A NUMBER LAST, IT INDICATES CONDUCTOR QUANTITY.
 3-THE WIRE SIZE CODING WILL NOT BE PRINTED ON WIRE LABEL WHEN LABELING WIRE WITH WIRE NO.

WIRE SIZE CODING CHART

WIRE SIZE	CODE LETTER
#2-#6	---i2
#6	---f
#8	---h
#10	---k
#12	---m
#14	---n
#16	---p
#18	---r
#14 (2 COND. SHLD.)	---e2
#14 (3 COND. SHLD.)	---e3
#18 (2 COND. SHLD.)	---e2
#18 (3 COND. SHLD.)	---e3
#18 (4 COND. SHLD.)	---e4

1200A MR CT RATINGS

CURRENT RATINGS	SECONDARY TAPS
100:5	X2-X3
200:5	X1-X2
300:5	X1-X3
400:5	X4-X5
500:5	X3-X4
600:5	X2-X4
800:5	X1-X4
900:5	X3-X5
1000:5	X2-X5
1200:5	X1-X5

GENERAL LEGEND

S2	VACUUM CIRCUIT BREAKER
CPT	CONTROL POWER TRANSFORMER
CT	CURRENT TRANSFORMER
PT	POTENTIAL TRANSFORMER
TS	TEST SWITCH
D	DEVICE TERMINAL ON EXTERNAL EQUIPMENT
○	DEVICE TERMINAL IN SWITCHGEAR
◇	TERMINAL BLOCK ON EXTERNAL EQUIPMENT
○	TERMINAL BLOCK IN SWITCHGEAR
⊙	TERMINAL BLOCK IN SUPV
⊗	BILL OF MATERIAL ITEM NUMBER

NOTES

REFERENCE DRAWINGS

ORIG. 22X34.DGN 05-03-99

REV	DATE	DFTR	APP	DESCRIPTION	REV	DATE	DFTR	APP	DESCRIPTION
08	-	-	-	-	04	-	-	-	-
07	-	-	-	-	03	-	-	-	-
06	-	-	-	-	02	-	-	-	-
05	-	-	-	-	01	05-01-2005	CEH	GKS	ORIGINAL ISSUE

SCALE:

MidAmerican ENERGY

DATE: 02/22/05
 DESIGNED: GKS
 DRAWN: SAG
 APPROVED: GKS

ABC CORPORATION
 CITY, STATE

INTERCONNECTION BREAKER 110 AC SCHEMATIC

DWG NO. E2

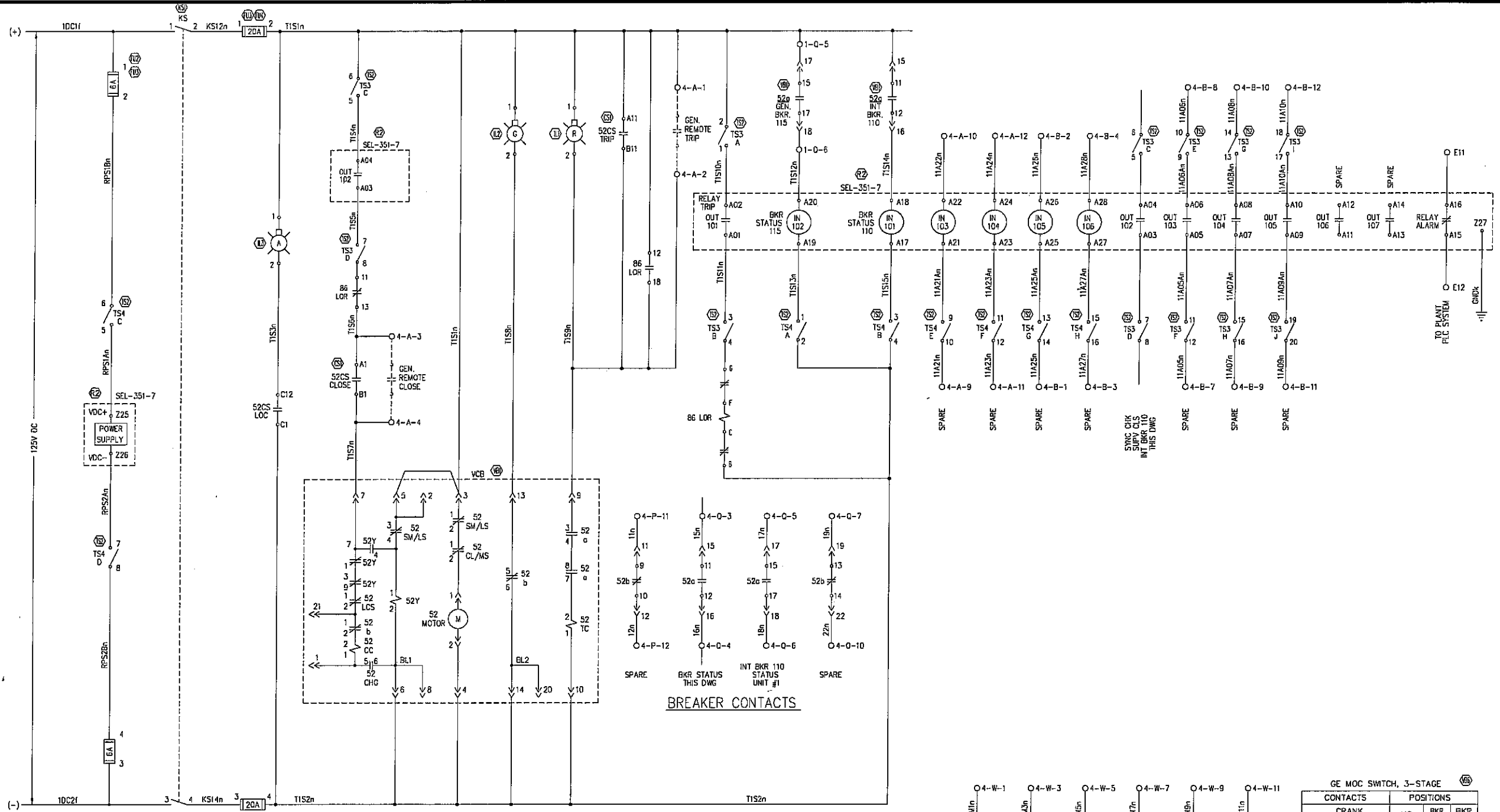

CIRCUIT BREAKER LEGEND	
52	CLOSING LATCH MONITORING SWITCH IS CLOSED WHEN LATCH IS CAPABLE OF BLOCKING FULLY CL/M/S
52 SM/L/S	LIMIT SWITCH FOR SPRING CHARGING MOTOR—CONTACTS (1-2)(3-4) OPEN WHEN SPRINGS ARE FULLY CHARGED.
52	CONTACTS CLOSED WHEN CLOSING SPRINGS ARE FULLY CHARGED.
52	CONTACTS CLOSED WHEN CLOSING SPRINGS ARE FULLY CHARGED.
52	SPRING RELEASE COIL OPERATES LATCH WHICH RELEASES CLOSING SPRING TO CLOSE CIRCUIT BREAKER.
52Y	ANTI-PUMP RELAY PREVENTS RECLOSING ON A SUSTAINED CLOSE COMMAND.
52ZC	TRIP LATCH CHECKING SWITCH CLOSED WHEN LATCH IS RESET.
M	SPRING CHARGING MOTOR
52TC	WHEN THE TRIP SKEWED IS ENERGIZED THE TRIP LATCH IS ROTATED, PERMITTING THE LINKAGE TO COLLAPSE AND THE VACUUM INTERRUPTER CONTACTS TO OPEN UNDER THE FORCE OF THE WIPE SPRINGS.
52c	AUXILIARY CONTACT THAT IS OPEN WHEN THE BREAKER IS OPEN.
52b	AUXILIARY CONTACT THAT IS CLOSED WHEN THE BREAKER IS OPEN.
GENERAL LEGEND	
52CS	CIRCUIT BREAKER CONTROL SWITCH
A	AMBER INDICATING LIGHT
G	GREEN INDICATING LIGHT
LOC	LOCAL
MOC/a	OPEN WHEN CIRCUIT BREAKER IS OPEN
MOC/b	CLOSED WHEN CIRCUIT BREAKER IS OPEN
REM	REMOTE
R	RED INDICATING LIGHT
TS	TEST SWITCH
□	DEVICE TERMINAL ON EXTERNAL EQUIPMENT
○	DEVICE TERMINAL IN SWITCHGEAR
◇	TERMINAL BLOCK ON EXTERNAL EQUIPMENT
○	TERMINAL BLOCK IN SWITCHGEAR
○	TERMINAL BLOCK IN SUPPLY
○	BILL OF MATERIAL ITEM NUMBER
NOTES	
CLOSING COIL CURRENT 8.0 AMPS	
TRIP COIL CURRENT 6.9 AMPS	
MOTOR CURRENT 23/8 AMPS (START/RUN)	
REFERENCE DRAWINGS	

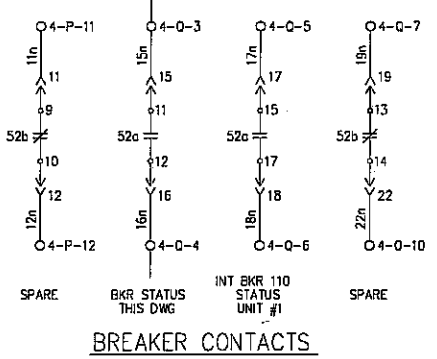

52CS				
CONTACTS	TRIP	PULL	PUSH	CLOSE
A11-B11	X			
A12-B12		X	X	
A1-B1				X
A5-B5	X			
A6-B6		X	X	
A7-B7				X
C12-C1	X	X		
D12-D1				X
C6-C7	X	X		
D6-D7				X
E12-E1	X	X		
F12-F1				X
E6-E7	X	X		
F6-F7				X

MAINTAINED WHEN PUSHED IN. PULL OUT TO TURN.

ELECTROSWITCH C#510A155G01

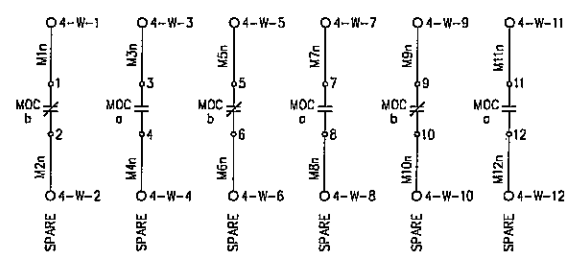
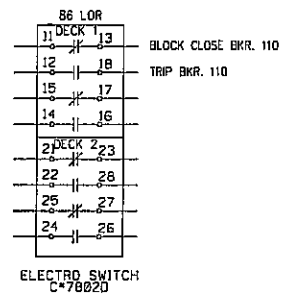

GE MOC SWITCH, 3-STAGE					
CONTACTS			POSITIONS		
CRANK	END		NO	BKR OPEN	BKR CLOSE
1	2	3	4	1-2	X
				3-4	X
5	6	7	8	5-6	X
				7-8	X
9	10	11	12	9-10	X
				11-12	X

WIRE SIZE CODING REVISED 07-15-01

1-THE LAST LETTER OF A WIRE NO. INDICATES WIRE SIZE (LOWER CASE) SEE CHART.

2-IF THERE IS A NUMBER LAST, IT INDICATES CONDUCTOR QUANTITY.

3-THE WIRE SIZE CODING WILL NOT BE PRINTED ON WIRE LABEL WHEN LABELING WIRE WITH WIRE NO.

WIRE SIZE CODING CHART

WIRE SIZE	CODE LETTER
2	#E
3	#F
4	#G
5	#H
6	#I
7	#J
8	#K
9	#L
10	#M
11	#N
12	#P
14	#Q
16	#R
18	#S
20	#T
22	#U
24	#V
26	#W
28	#X
30	#Y
32	#Z

ORIG. 22X34-00N 05-03-99

REV	DATE	DFTR	APP	DESCRIPTION
08	-	-	-	-
07	-	-	-	-
06	-	-	-	-
05	-	-	-	-

REV	DATE	DFTR	APP	DESCRIPTION
04	-	-	-	-
03	-	-	-	-
02	-	-	-	-
01	05-01-2005	CEH	GKS	ORIGINAL ISSUE

	DATE: 02/23/05	ABC CORPORATION CITY, STATE	DWG NO E3
	DESIGNED: GKS		
	DRAWN: SAG		
APPROVED: GKS	INTERCONNECTION BREAKER 110 DC SCHEMATIC		

SCALE:

UPPER LEFT SIDE WALL

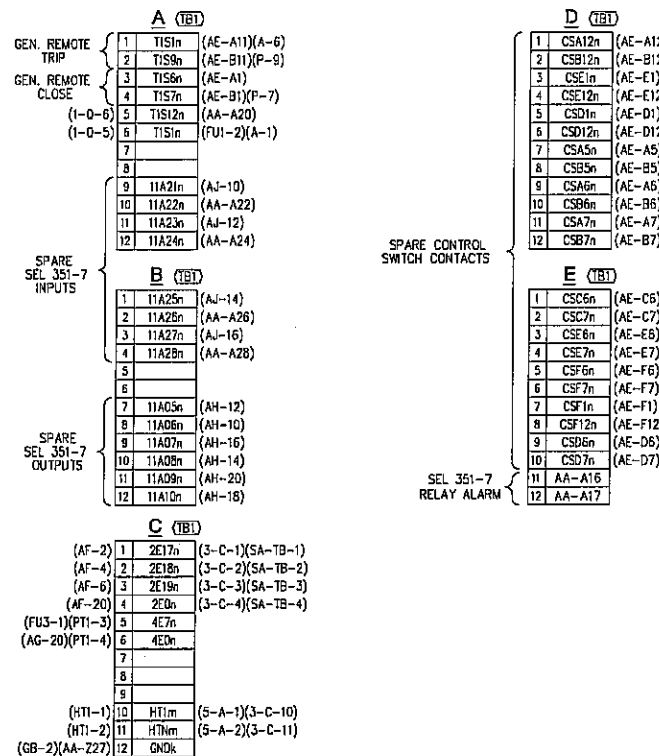

CELL - FRONT VIEW

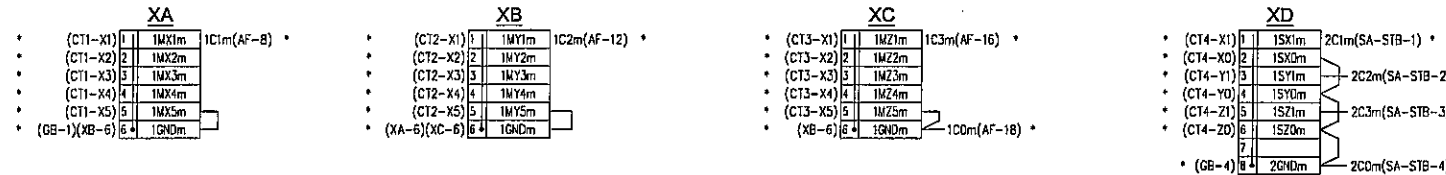
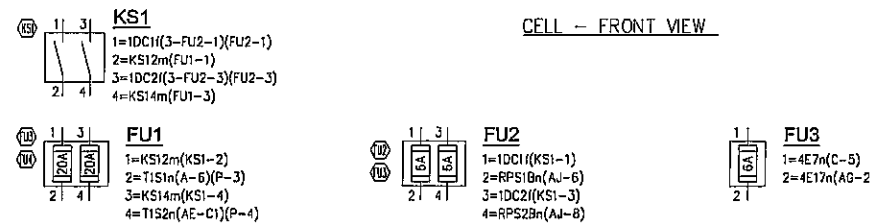

BREAKER CELL

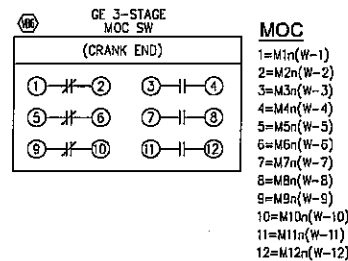

PT COMPARTMENT

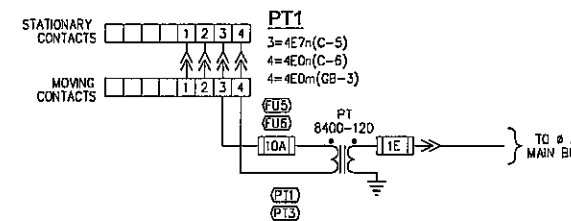

UPPER RIGHT SIDE WALL

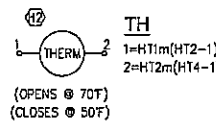
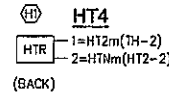
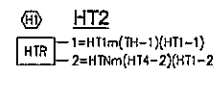
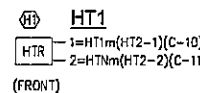
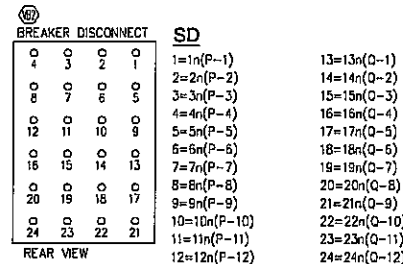
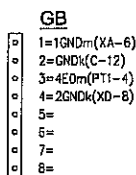
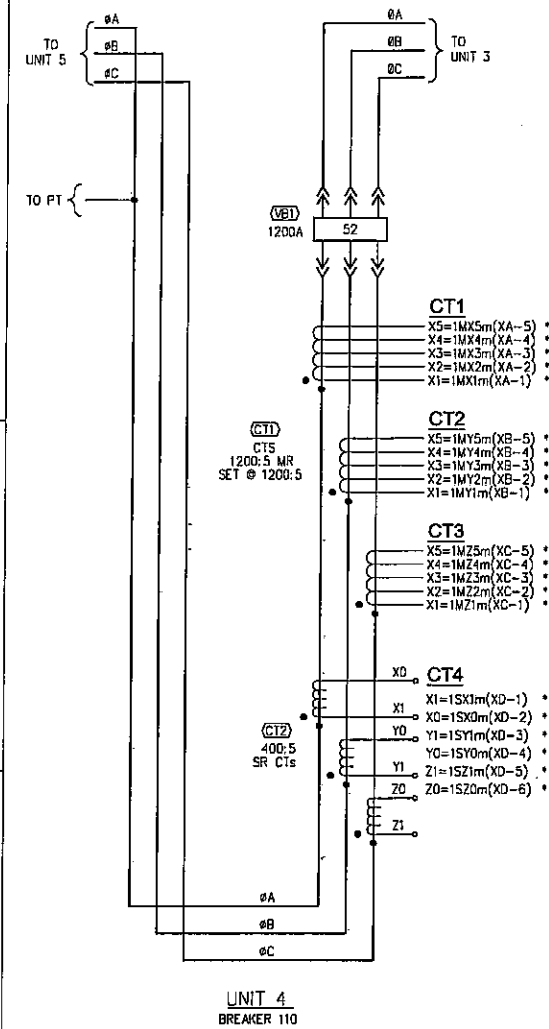
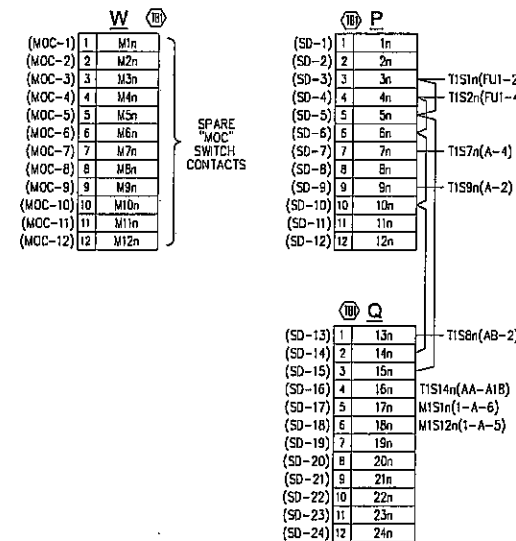

NOTES:

- WIRES TO BE LABELED WITH WIRE NUMBERS PRINTED ON BRADY'S COMPUTER PRINTED WRAP-ON WIRE LABELS.
- ⊙ INDICATES BILL OF MATERIAL ITEM NUMBER.
- CURRENT CIRCUIT WIRES ARE TO BE TERMINATED WITH INSULATED RING TONGUE LUGS. CURRENT WIRES ARE MARKED WITH (*). ALL OTHER CONTROL WIRES ARE TO BE TERMINATED WITH INSULATED LOCKING FORK LUGS.

"WIRE SIZE CODING" REVISED 07-16-01

1-THE LAST LETTER OF A WIRE NO. INDICATES WIRE SIZE (LOWER CASE) SEE CHART.

2-IF THERE IS A NUMBER LAST, IT INDICATES CONDUCTOR QUANTITY.

3-THE WIRE SIZE CODING WILL NOT BE PRINTED ON WIRE LABEL WHEN LABELING WIRE WITH WIRE NO.

WIRE SIZE CODING CHART

WIRE SIZE	CODE LETTER
2-#6	-----12
#8	-----f
#10	-----h
#12	-----m
#14	-----n
#16	-----p
#18	-----r
#14 (2) COND. SHLD.	---s2
#14 (3) COND. SHLD.	---s3
#18 (2) COND. SHLD.	---s2
#18 (3) COND. SHLD.	---s3
#18 (4) COND. SHLD.	---s4

DRG. 22X33-DEN 05-03-99

REV	DATE	DFTR	APP	DESCRIPTION
08				
07				
06				
05				
01	05-01-2005	CEH	GKS	ORIGINAL ISSUE

SCALE:

MidAmerican ENERGY

DATE: 02/23/05
DESIGNED: GKS
DRAWN: SAG
APPROVED: GKS

ABC CORPORATION
CITY, STATE

INTERCONNECTION BREAKER 110
WIRING DIAGRAM, PART 1 OF 2

DWG NO

E4

SEL 351-7

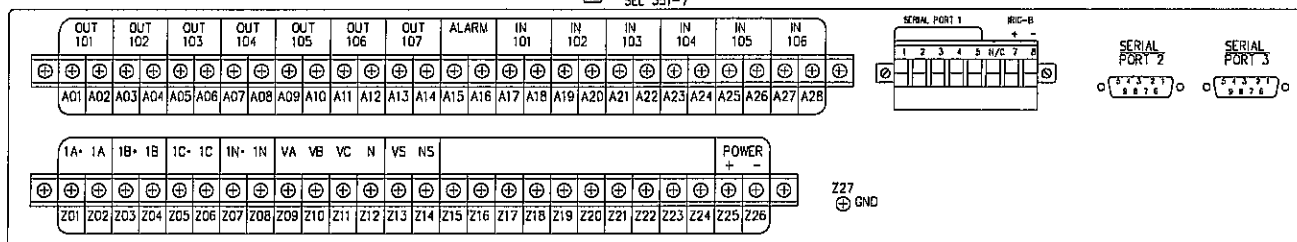

AA

- A01=11S1n(AH-3)
- A02=11S10n(AH-1)
- A03=11S5n(AH-7)
- A04=11S4n(AH-5)
- A05=11A05An(AH-11)
- A06=11A08An(AH-9)
- A07=11A07An(AH-15)
- A08=11A08An(AH-13)
- A09=11A09An(AH-19)
- A10=11A10An(AH-17)
- A11=
- A12=
- A13=
- A14=
- A15=(E-12)
- A16=(E-11)
- A17=11S15n(AJ-3)
- A18=11S14n(AJ-4)
- A19=11S13n(AJ-1)
- A20=11S12n(AJ-5)
- A21=11A21An(AJ-9)
- A22=11A22n(AJ-10)
- A23=11A23An(AJ-11)
- A24=11A24n(AJ-12)
- A25=11A25An(AJ-13)
- A26=11A26n(B-2)
- A27=11A27An(AJ-15)
- A28=11A28n(B-4)
- Z01=1C11m(AF-7)
- Z02=1C21m(AF-9)
- Z03=1C12m(AF-11)
- Z04=1C22m(AF-13)
- Z05=1C13m(AF-15)
- Z06=1C23m(AF-17)
- Z07=
- Z08=
- Z09=2E27n(AF-1)
- Z10=2E28n(AF-3)
- Z11=2E29n(AF-5)
- Z12=2E20n(AF-15)
- Z13=4E27n(AG-1)
- Z14=4E28n(AG-19)
- Z25=RPS1An(AJ-5)
- Z26=RPS2An(AJ-7)
- Z27=GNDK(B-12)
- SP1=
- SP2=
- SP3=

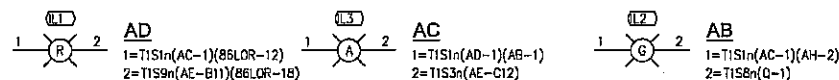

(CS1) 52CS

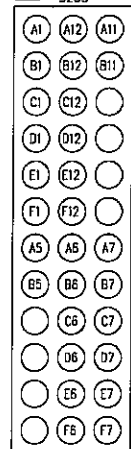

AE

- A1=11S6n(AH-B)(A-3)
- A11=11S1n(AH-5)(A-1)
- A12=CSA12n(D-1)
- B1=11S7n(A-4)
- B11=11S9n(AD-2)(A-2)
- B12=CSB12n(D-2)
- C1=11S2n(AJ-4)(FU1-4)(86LOR-B)
- C12=11S3n(AC-2)
- D1=CSD1n(D-5)
- D12=CSD12n(D-6)
- E1=CSE1n(D-3)
- E12=CSE12n(D-4)
- F1=CSF1n(E-7)
- F12=CSF12n(E-8)
- A5=CSA5n(D-7)
- A6=CSA6n(D-8)
- A7=CSA7n(D-11)
- B5=CSB5n(D-8)
- B6=CSB6n(D-10)
- B7=CSB7n(D-12)
- C6=CSC6n(E-1)
- C7=CSC7n(E-2)
- D6=CSD6n(E-9)
- D7=CSD7n(E-10)
- E6=CSE6n(E-3)
- E7=CSE7n(E-4)
- F6=CSF6n(E-5)
- F7=CSF7n(E-6)

86 LOR

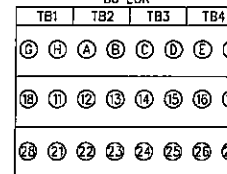

- B-11S2n(AE-C1)
- G-(AH-4)
- 11-MIS4n(AD-B1)(AF-2)
- 12-11S1n(AD-1)
- 13-MIS7n(A-3)
- 14-
- 15-
- 16-
- 17-
- 18-11S9n(AD-2)
- 21-
- 22-
- 23-
- 24-
- 25-
- 26-
- 27-
- 28-

(TS2) TS2

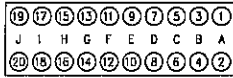

AG

- 1=4E27n(AA-213)
- 2=4E17n(FU3-2)
- 3=
- 4=
- 5=
- 6=
- 7=
- 8=
- 9=
- 10=

- 11=
- 12=
- 13=
- 14=
- 15=
- 16=
- 17=
- 18=
- 19=4E20n(AA-214)
- 20=4E0n(C-6)

(TS1) TS1

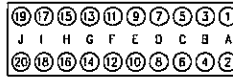

AF

- 1=2E27n(AA-209)
- 2=2E17n(C-1)
- 3=2E28n(AA-210)
- 4=2E18n(C-2)
- 5=2E29n(AA-211)
- 6=2E19n(C-3)
- 7=1C11m(AA-201)
- 8=1C1m(XA-1)
- 9=1C21m(AA-202)
- 10=1C0m(AF-14)

- 11=1C12m(AA-203)
- 12=1C2m(XB-1)
- 13=1C22m(AA-204)
- 14=1C0m(AF-10)(AF-18)
- 15=1C13m(AA-205)
- 16=1C3m(XC-1)
- 17=1C23m(AA-206)
- 18=1C0m(AF-14)(XC-6)
- 19=2E20n(AA-212)
- 20=2E0n(C-4)

NOTES:

1. WIRES TO BE LABELED WITH WIRE NUMBER PRINTED ON BRADY'S COMPUTER PRINTED WRAP-ON WIRE LABELS.
2. INDICATES BILL OF MATERIAL ITEM NUMBER.
3. CURRENT CIRCUIT WIRES ARE TO BE TERMINATED WITH INSULATED RING TONGUE LUGS. CURRENT WIRES ARE MARKED WITH (*). ALL OTHER CONTROL WIRES ARE TO BE TERMINATED WITH INSULATED LOCKING FORK LUGS.

"WIRE SIZE CODING" REVISED 07-16-01

- 1-THE LAST LETTER OF A WIRE NO. INDICATES WIRE SIZE (LOWER CASE) SEE CHART.
- 2-IF THERE IS A NUMBER LAST, IT INDICATES CONDUCTOR QUANTITY.
- 3-THE WIRE SIZE CODING WILL NOT BE PRINTED ON WIRE LABEL WHEN LABELING WIRE WITH WIRE NO.

WIRE SIZE CODING CHART

WIRE SIZE	CODE LETTER
2-#6	-----f2
#8	-----h
#10	-----k
#12	-----m
#14	-----n
#16	-----p
#18	-----r
#14 (2) COND. SHLD.	---g2
#14 (3) COND. SHLD.	---g3
#18 (2) COND. SHLD.	---s2
#18 (3) COND. SHLD.	---s3
#18 (4) COND. SHLD.	---s4

REV	DATE	DFTR	APP	DESCRIPTION	REV	DATE	DFTR	APP	DESCRIPTION
08	-	-			04	-	-		
07	-	-			03	-	-		
06	-	-			02	-	-		
05	-	-			01	05-01-2005	CEH	GKS	ORIGINAL ISSUE

SCALE:



DATE: 02/23/05
DESIGNED: GKS
DRAWN: SAG
APPROVED: GKS

ABC CORPORATION
CITY, STATE

INTERCONNECTION BREAKER 110
WIRING DIAGRAM, PART 2 OF 2

D
W
G
N
D

E5

GENERAL LEGEND	
S2	VACUUM CIRCUIT BREAKER
CPT	CONTROL POWER TRANSFORMER
CT	CURRENT TRANSFORMER
PT	POTENTIAL TRANSFORMER
TS	TEST SWITCH
□	DEVICE TERMINAL ON EXTERNAL EQUIPMENT
○	DEVICE TERMINAL IN SWITCHGEAR
◇	TERMINAL BLOCK ON EXTERNAL EQUIPMENT
⊙	TERMINAL BLOCK IN SWITCHGEAR
⊚	TERMINAL BLOCK IN SUPV
⊛	BILL OF MATERIAL ITEM NUMBER
NOTES	
REFERENCE DRAWINGS	

"WIRE SIZE CODING" REVISED 07-16-01

1-THE LAST LETTER OF A WIRE NO. INDICATES WIRE SIZE (LOWER CASE) SEE CHART.
 2-IF THERE IS A NUMBER LAST, IT INDICATES CONDUCTOR QUANTITY.
 3-THE WIRE SIZE CODING WILL NOT BE PRINTED ON WIRE LABEL WHEN LABELING WIRE WITH WIRE NO.

WIRE SIZE	CODE LETTER
#2	-----f2
#6	-----f
#8	-----h
#10	-----k
#12	-----m
#14	-----n
#16	-----p
#18	-----r
#14 (2) COND. SHLD.	---s2
#14 (3) COND. SHLD.	---s3
#18 (2) COND. SHLD.	---s2
#18 (3) COND. SHLD.	---s3
#18 (4) COND. SHLD.	---s4

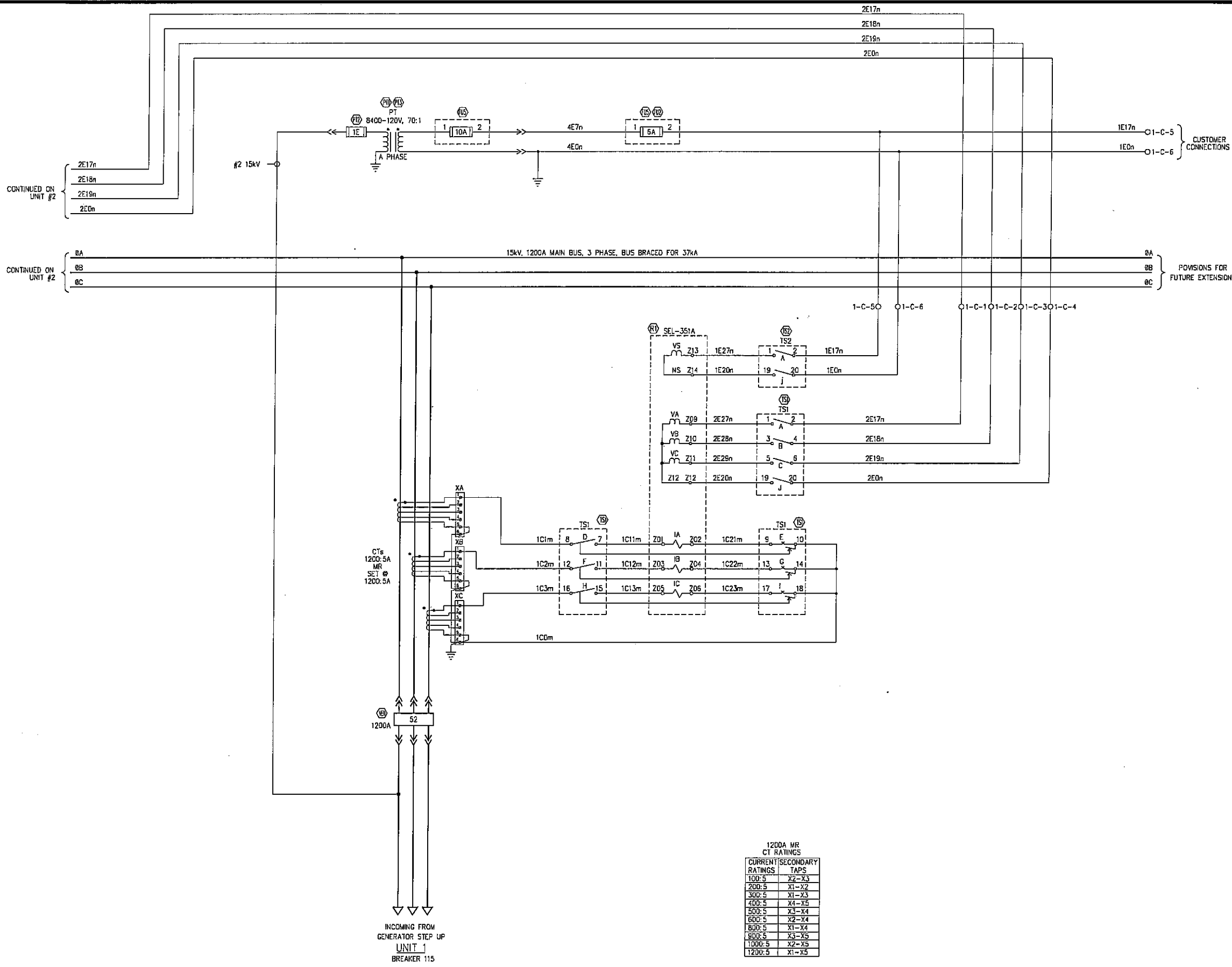

1200A MR CT RATINGS

CURRENT RATINGS	SECONDARY TAPS
100:5	X2-X3
200:5	X1-X2
300:5	X1-X3
400:5	X4-X5
500:5	X3-X4
600:5	X2-X4
800:5	X1-X4
900:5	X3-X5
1000:5	X2-X5
1200:5	X1-X5

ORIG: 22X34.DGN 05-03-99

REV	DATE	DFTR	APP	DESCRIPTION
08	-	-	-	-
07	-	-	-	-
06	-	-	-	-
05	-	-	-	-
04	-	-	-	-
03	-	-	-	-
02	-	-	-	-
01	05-01-2005	CEH	GKS	ORIGINAL ISSUE

SCALE:



DATE: 02/22/05
 DESIGNED: GKS
 DRAWN: SAG
 APPROVED: GKS

ABC CORPORATION
 CITY, STATE
GENERATOR INCOMING BREAKER 115 AC
SCHEMATIC

DWG NO
E6

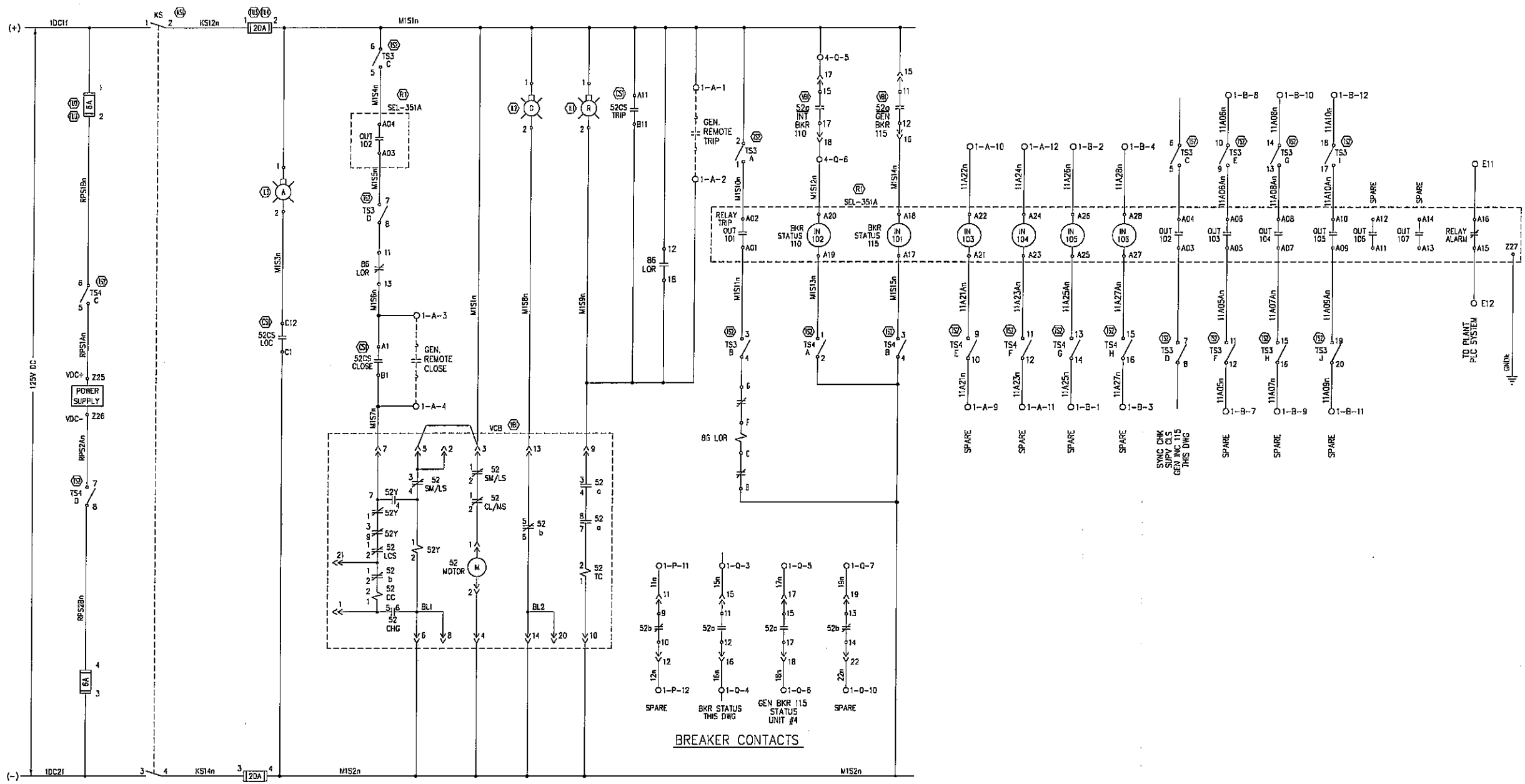

CIRCUIT BREAKER LEGEND

52 CLOSING LATCH MONITORING SWITCH IS CLOSED WHICH LATCH IS CAPABLE OF BLOCKING FULLY CHARGED CLOSING SPRING, HELD OPEN BETWEEN DISCONNECT & CONNECT POSITIONS

52 S/WALS LIMIT SWITCH FOR SPRING CHARGING MOTOR-CONTACTS (1-2)(3-4) OPEN WHEN SPRINGS ARE FULLY CHARGED

52G CONTACTS CLOSED WHEN CLOSING SPRINGS ARE FULLY CHARGED

52CC SPRING RELEASE COIL OPERATES LATCH WHICH RELEASES CLOSING SPRING TO CLOSE CIRCUIT BREAKER

52Y ANTI-PUMP RELAY PREVENTS RE-CLOSING ON A SUSTAINED CLOSE COMMAND

52 TRIP LATCH CHECKING SWITCH CLOSED WHEN LATCH IS RESET

M SPRING CHARGING MOTOR

WHEN THE TRIP SOLENOID IS ENERGIZED THE TRIP LATCH IS RELEASING PERMITTING THE LINKAGE TO COLLAPSE AND THE VACUUM INTERRUPTER CONTACTS TO OPEN UNDER THE FORCE OF THE WPE SPRINGS

52a AUXILIARY CONTACT THAT IS OPEN WHEN THE BREAKER IS OPEN

52b AUXILIARY CONTACT THAT IS CLOSED WHEN THE BREAKER IS OPEN

GENERAL LEGEND

S2CS CIRCUIT BREAKER CONTROL SWITCH

A AMBER INDICATING LIGHT

G GREEN INDICATING LIGHT

LCC LCC

MOC/a OPEN WHEN CIRCUIT BREAKER IS OPEN

MOC/b CLOSED WHEN CIRCUIT BREAKER IS OPEN

REM REMOTE

R RED INDICATING LIGHT

TS TEST SWITCH

W WHITE INDICATING LIGHT

W DEVICE TERMINAL ON EXTERNAL EQUIPMENT

B DEVICE TERMINAL IN SWITCHGEAR

o TERMINAL BLOCK ON EXTERNAL EQUIPMENT

o TERMINAL BLOCK IN SWITCHGEAR

o TERMINAL BLOCK IN SUPPLY

o BILL OF MATERIAL ITEM NUMBER

NOTES

CLOSING COIL CURRENT 5.0 AMPS

TRIP COIL CURRENT 6.5 AMPS

MOTOR CURRENT 23/8 AMPS (START/RUN)

REFERENCE DRAWINGS

WIRE SIZE CODING REWDED 07-15-01

1-THE LAST LETTER OF A WIRE NO. INDICATES WIRE SIZE (LOWER CASE) SEE CHART.

2-IF THERE IS A NUMBER LAST, IT INDICATES CONDUCTOR QUANTITY.

3-THE WIRE SIZE CODING WILL NOT BE PRINTED ON WIRE LABEL WHICH LABELING WIRE WITH WIRE NO.

WIRE SIZE CODING CHART

WIRE SIZE	CODE LETTER
2	A
3	B
4	C
5	D
6	E
7	F
8	G
9	H
10	J
11	K
12	L
13	M
14	N
15	P
16	Q
17	R
18	S
19	T
20	U
21	V
22	W
23	X
24	Y
25	Z

NOTE:

1-ALL WIRING IN H/V COMPARTMENTS TO BE RUN IN METAL JACKETED WIRE OR CONDUIT.

2-WIRING RUN IN CONDUIT SHOULD BE THRU, EXCEPT FOR SHORT RUNS. SIZED PER REC.

S2CS

CONTACTS	TRIP	PULL	PUSH	CLOSE	MAINTAINED WHEN PUSHED IN. PULL OUT TO TURN.	CONTACT FUNCTION
A11-B11	X					TRIP BREAKER
A12-B12		X	X			SPARE
A1-B1				X		CLOSE BREAKER
A5-B5	X					SPARE
A6-B6		X	X			SPARE
A7-B7				X		SPARE
C12-C1	X	X	X	X		AMBER LIGHT
D12-D1				X		SPARE
C5-C7	X	X	X	X		SPARE
D5-D7			X			SPARE
E12-E1	X	X	X	X		SPARE
F12-F1			X			SPARE
E6-E7	X	X	X	X		SPARE
F6-F7			X			SPARE

ELECTROSWITCH: C#510A155G01

B6 LOR

11 DECK	13	BLOCK CLOSE BKR. 115
11	13	
12	18	TRIP BKR. 115
15	17	
14	18	
2 DECK	23	
22	28	
25	27	
24	28	

ELECTRO SWITCH C#7802D

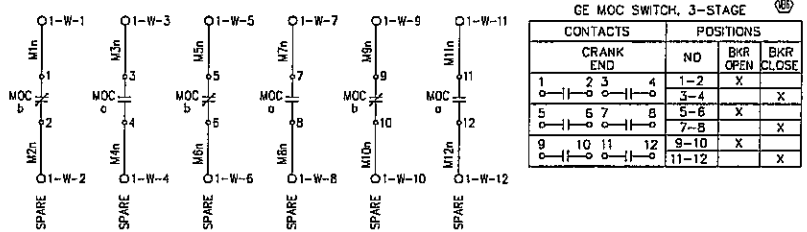

ORIG. 22X34.DGN 05-03-99

REV	DATE	DFTR	APP	DESCRIPTION
08	-	-	-	-
07	-	-	-	-
06	-	-	-	-
05	-	-	-	-
01	05-01-2005	CEH	GKS	ORIGINAL ISSUE

REV	DATE	DFTR	APP	DESCRIPTION
04	-	-	-	-
03	-	-	-	-
02	-	-	-	-

MidAmerican ENERGY

DATE: 02/23/05
 DESIGNED: GKS
 DRAWN: SAG
 APPROVED: GKS

ABC CORPORATION
 CITY, STATE

GENERATOR INCOMING BREAKER 115 DC
 SCHEMATIC

DWG NO. **E7**

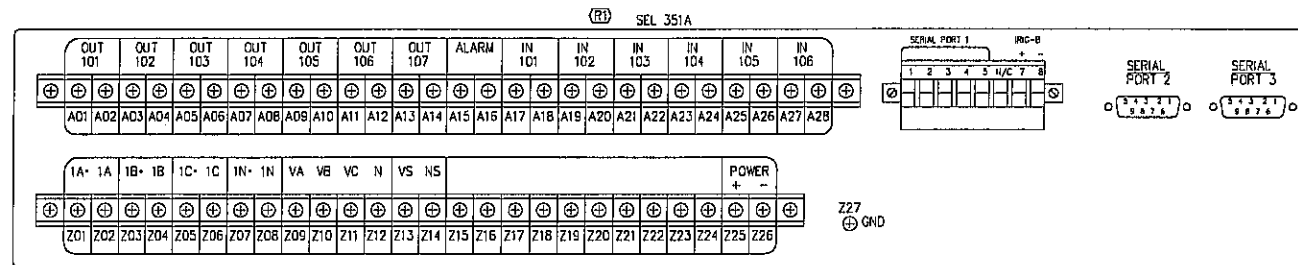

AA

- A01=M1S11n(AH-3)
- A02=M1S10n(AH-1)
- A03=M1S5n(AH-7)
- A04=M1S4n(AH-5)
- A05=M1A05An(AH-11)
- A06=M1A06An(AH-9)
- A07=M1A07An(AH-15)
- A08=M1A08An(AH-13)
- A09=M1A09An(AH-19)
- A10=M1A10An(AH-17)
- A11=
- A12=
- A13=
- A14=
- A15=(E-12)
- A16=(E-11)
- A17=M1S15n(AJ-3)
- A18=M1S14n(O-4)
- A19=M1S13n(AJ-1)
- A20=M1S12n(A-5)
- A21=M1A21An(AJ-9)
- A22=M1A22An(A-10)
- A23=M1A23An(AJ-11)
- A24=M1A24n(A-12)
- A25=M1A25An(AJ-13)
- A26=M1A26n(B-2)
- A27=M1A27An(AJ-15)
- A28=M1A28n(B-4)
- Z01=M1C11m(AF-7)
- Z02=M1C21m(AF-9)
- Z03=M1C12m(AF-11)
- Z04=M1C22m(AF-13)
- Z05=M1C13m(AF-15)
- Z06=M1C23m(AF-17)
- Z07=
- Z08=
- Z09=M2E27n(AF-1)
- Z10=M2E28n(AF-3)
- Z11=M2E29n(AF-5)
- Z12=M2E20n(AF-19)
- Z13=M1E27n(AG-1)
- Z14=M1E20n(AG-19)
- Z25=RPS1An(AJ-5)
- Z26=RPS2An(AJ-7)
- Z27=GNDk(C-12)
- SP1=
- SP2=
- SP3=

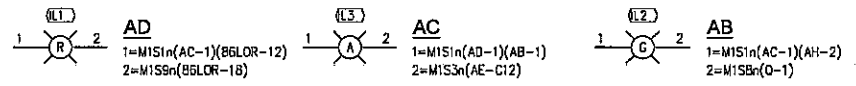

AE

- A1=M1S5n(AH-8)(A-3)
- A11=M1S1n(AH-6)(A-1)
- A12=CSA12n(D-1)
- B1=M1S7n(A-4)
- B11=M1S9n(A-2)
- B12=CSB12n(D-2)
- C1=M1S2n(AJ-4)(FU1-4)(BGLOR-B)
- C12=M1S3n(AC-2)
- D1=CSO1n(D-5)
- D12=CSO12n(D-5)
- E1=CSE1n(D-3)
- E12=CSE12n(D-4)
- F1=CSF1n(E-7)
- F12=CSF12n(E-8)
- A5=CSA5n(D-7)
- A6=CSA6n(D-9)
- A7=CSA7n(D-11)
- B5=CSB5n(D-8)
- B6=CSB6n(D-10)
- B7=CSB7n(D-12)
- C6=CSC6n(E-1)
- C7=CSC7n(E-2)
- D6=CSO6n(E-9)
- D7=CSO7n(E-10)
- E6=CSE6n(E-3)
- E7=CSE7n(E-4)
- F6=CSF6n(E-5)
- F7=CSF7n(E-5)

B6 LOR

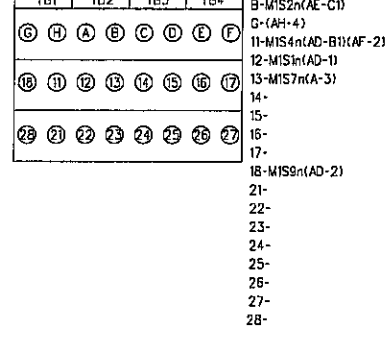

AG

- 1=M1E27n(AA-Z13)
- 2=M1E17n(C-5)
- 3=
- 4=
- 5=
- 6=
- 7=
- 8=
- 9=
- 10=
- 11=
- 12=
- 13=
- 14=
- 15=
- 16=
- 17=
- 18=
- 19=M1E20n(AA-Z14)
- 20=M1E0n(C-6)

AJ

- 1=M1S13n(AA-A19)
- 2=M1S2n(AJ-4)
- 3=M1S15n(AA-A17)
- 4=M1S2n(AJ-2)(AE-C1)
- 5=RPS1An(AA-Z25)
- 6=RPS1Bn(FU2-2)
- 7=RPS2An(AA-Z26)
- 8=RPS2Bn(FU2-4)
- 9=M1A21An(AA-A21)
- 10=M1A21n(A-9)
- 11=M1A23An(AA-A23)
- 12=M1A23n(A-11)
- 13=M1A25An(AA-A25)
- 14=M1A25n(B-1)
- 15=M1A27An(AA-A27)
- 16=M1A27n(B-3)
- 17=
- 18=
- 19=
- 20=

AF

- 1=M2E27n(AA-Z09)
- 2=M2E17n(C-1)
- 3=M2E28n(AA-Z10)
- 4=M2E18n(C-2)
- 5=M2E29n(AA-Z11)
- 6=M2E19n(C-3)
- 7=M1C11m(AA-Z01)
- 8=M1C1m(XA-1)
- 9=M1C21m(AA-Z12)
- 10=M1C0m(AF-14)
- 11=M1C12m(AA-Z03)
- 12=M1C2m(XB-1)
- 13=M1C22m(AA-Z04)
- 14=M1C0m(AF-10)(AF-18)
- 15=M1C13m(AA-Z05)
- 16=M1C3m(XC-1)
- 17=M1C23m(AA-Z06)
- 18=M1C0m(AF-14)(XC-6)
- 19=M2E20n(AA-Z12)
- 20=M2E0n(C-4)

AH

- 1=M1S10n(AA-A02)
- 2=M1S1n(AB-1)(AH-6)
- 3=M1S11n(AA-A01)
- 4=(BGLOR-G)
- 5=M1S4n(AA-A04)
- 6=M1S1n(AH-2)(AE-A11)
- 7=M1S5n(AA-A03)
- 8=M1S5n(AE-A1)
- 9=M1A05An(AA-A06)
- 10=M1A06n(B-8)
- 11=M1A05An(AA-A05)
- 12=M1A05n(B-7)
- 13=M1A08An(AA-A08)
- 14=M1A08n(B-10)
- 15=M1A07An(AA-A07)
- 16=M1A07n(B-9)
- 17=M1A10An(AA-A10)
- 18=M1A10n(B-12)
- 19=M1A09An(AA-A09)
- 20=M1A09n(B-11)

NOTES:

1. WIRES TO BE LABELED WITH WIRE NUMBER PRINTED ON BRADY'S COMPUTER PRINTED WRAP-ON WIRE LABELS.
2. INDICATES BILL OF MATERIAL ITEM NUMBER.
3. CURRENT CIRCUIT WIRES ARE TO BE TERMINATED WITH INSULATED RING TONGUE LUGS. CURRENT WIRES ARE MARKED WITH (*). ALL OTHER CONTROL WIRES ARE TO BE TERMINATED WITH INSULATED LOCKING FORK LUGS.

"WIRE SIZE CODING" REVISED 07-18-01
 1-THE LAST LETTER OF A WIRE NO. INDICATES WIRE SIZE (LOWER CASE) SEE CHART.
 2-F THERE IS A NUMBER LAST, IT INDICATES CONDUCTOR QUANTITY.
 3-THE WIRE SIZE CODING WILL NOT BE PRINTED ON WIRE LABEL WHEN LABELING WIRE WITH WIRE NO.

WIRE SIZE CODING CHART

WIRE SIZE	CODE LETTER
2-#6	---f
#6	-----f
#8	-----h
#10	-----k
#12	-----m
#14	-----n
#16	-----p
#18	-----r
#14 (2) COND. SHLD.	---o2
#14 (3) COND. SHLD.	---o3
#18 (2) COND. SHLD.	---e2
#18 (3) COND. SHLD.	---e3
#18 (4) COND. SHLD.	---e4

ORIG: 22X34.DGN 05-03-99

REV	DATE	DFT	APP	DESCRIPTION	REV	DATE	DFT	APP	DESCRIPTION
08	-	-			04	-	-		
07	-	-			03	-	-		
06	-	-			02	-	-		
05	-	-			01	05-01-2005	CEH	GKS	ORIGINAL ISSUE

SCALE:



DATE: 02/23/05
 DESIGNED: GKS
 DRAWN: SAG
 APPROVED: GKS

ABC CORPORATION
 CITY, STATE

GENERATOR INCOMING BREAKER 115
 WIRING DIAGRAM, PART 2 OF 2

D
W
G
N
O

E9

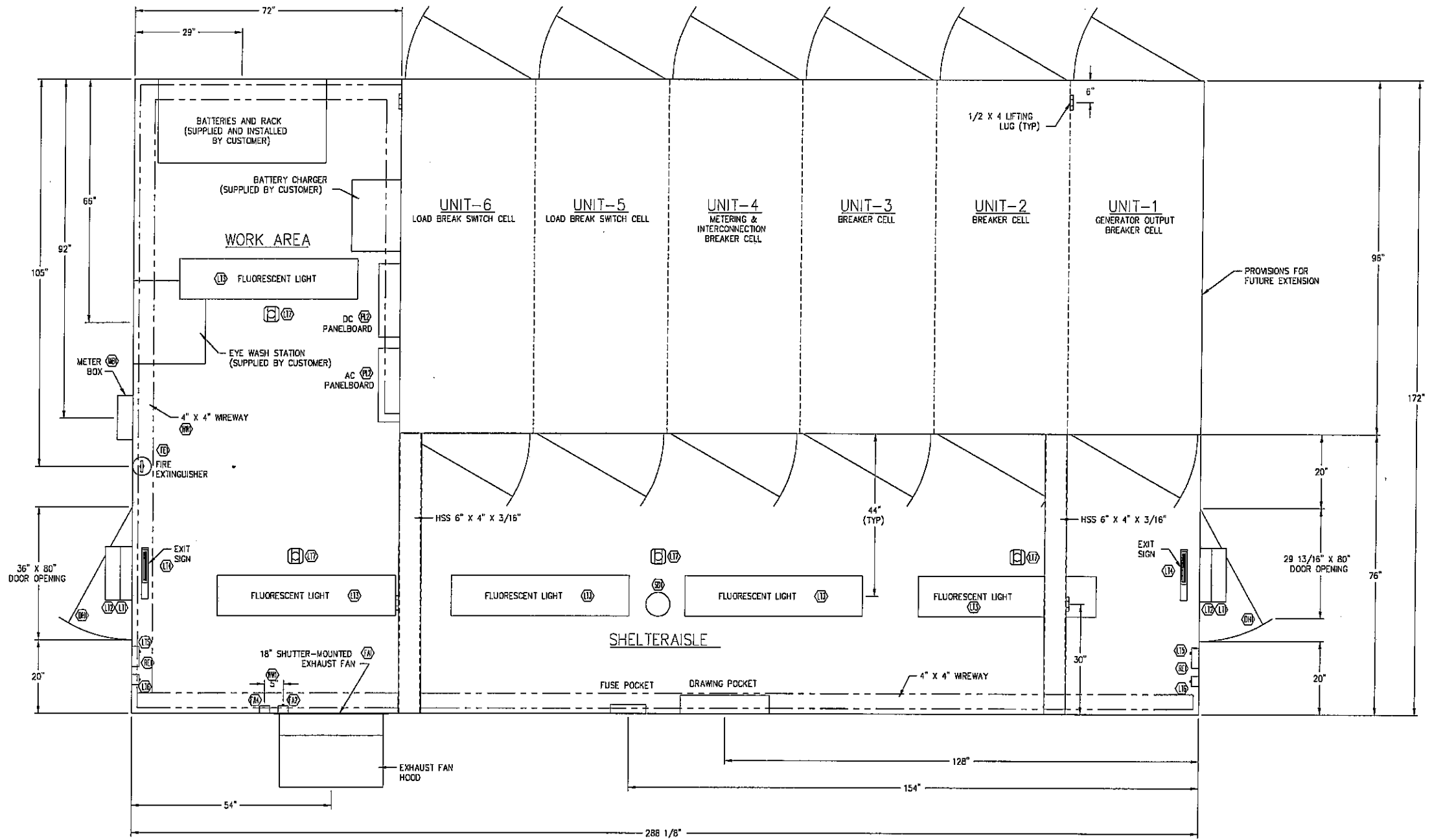

PLAN VIEW

NOTE:
 1. INDICATES BILL OF MATERIAL ITEM NUMBER.

ORIG. 22X34.DGN 05-03-99

REV	DATE	DFTR	APP	DESCRIPTION
08	--			
07	--			
06	--			
05	--			
04	--			
03	--			
02	--			
01	05-01-2005	CEH	GKS	ORIGINAL ISSUE

SCALE:



DATE: 02/24/05
 DESIGNED: GKS
 DRAWN: SAG
 APPROVED: GKS

ABC CORPORATION
 CITY, STATE
SWITCHGEAR PLAN LAYOUT

DWG
 NO
E10

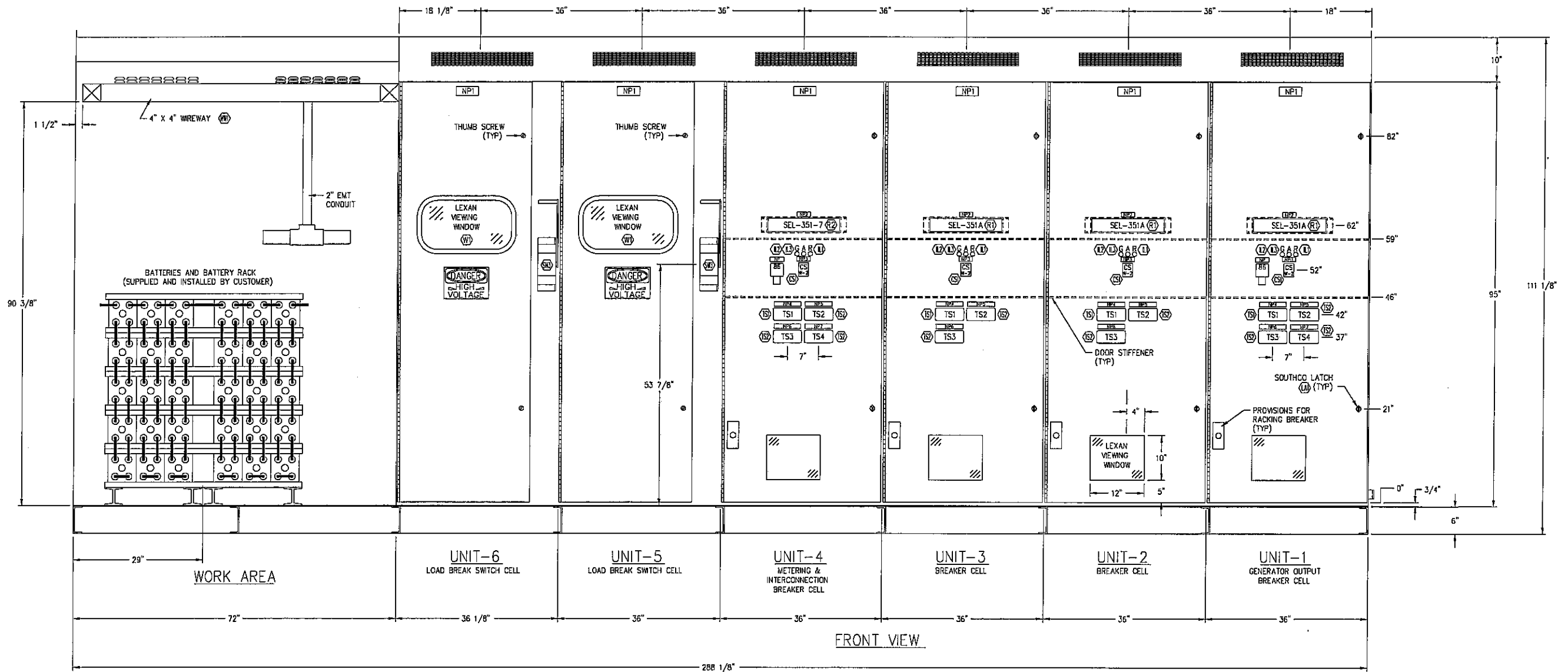

- NOTES:**
1. FABRICATED FROM 11GA. STEEL, WELDED UNITIZED CONSTRUCTION WITH ALL CORNERS WELDED AND GROUND SMOOTH.
 2. CLEAN WITH A PHOSPHATIZED SURFACE CLEANER, PRIME AND PAINT.
 3. ALL RELAY DOORS TO HAVE SLIDE LATCHING DOOR STOPS (TYP).
 4. ○ INDICATES BILL OF MATERIAL ITEM NUMBER.

ORIG. 22X34.DGN 05-03-95

REV	DATE	DFTR	APP	DESCRIPTION	REV	DATE	DFTR	APP	DESCRIPTION
05	-	-			04	-	-		
07	-	-			03	-	-		
06	-	-			02	-	-		
05	-	-			01	05-01-2005	CEH	GKS	ORIGINAL ISSUE

SCALE:



DATE: 02/24/05
 DESIGNED: GKS
 DRAWN: SAG
 APPROVED: GKS

ABC CORPORATION
 CITY, STATE
 SWITCHGEAR SECTION VIEW

DWG
 NO
E11

Appendix F: Contact Forms

Preliminary Approval Contact Form

Project Identification:

Project Name: _____

Facility Name and Location: _____

Applicant Information:

Facility Owner (*applicant*):

Name: _____

MEC Service Account Number (if known): _____

Address: _____

Phone: _____

Facility Owner Primary Contact:

Name: _____

Address (if different from above):

Day Phone: _____ Night Phone: _____

Mobile: _____ Pager: _____

Fax: _____ Email: _____

Continued on the following page.

		Technical Requirements for Interconnection of Generation to the MidAmerican Energy Company Distribution System (<i>TRIMECS</i>)	APPENDIX F
REVISION 1.0	ISSUED 05/01/05		

Appendix F: Design Approval Contact Forms

Design Approval Contact Form

Project Name: _____

Facility Name and Location: _____

Sheet ____ of ____ for the above project.

Is this person the **single-point-of-contact (SPC)** for the project? Yes No

Function (check one or more of the following):

Project Management Engineering (design of the interconnection installation)

Electrical Contractor Relay Engineer (in charge of providing IPR settings)

Testing Contractor (in charge of performing IPR testing)

Equipment Manufacturer or Supplier-please specify equipment provided below:

Is this person performing subcontracting work for someone other than the Facility Owner? Yes No

If yes, please specify: _____

Name: _____

Company: _____

Address:

Day Phone: _____ Night Phone: _____

Mobile: _____ Pager: _____

Fax: _____ Email: _____

		Technical Requirements for Interconnection of Generation to the MidAmerican Energy Company Distribution System (TRIMECS)	APPENDIX F
REVISION 1.0	ISSUED 05/01/05		

Appendix R: Interconnection Protective Relay (IPR) Elements Guide

AR1.0 Each of the following protective relay functions is required at the interconnection point between the MEC system and the **facility owner's** facility. The protective relay functions may be implemented through several single-function protective relays or a single multi-function protective relay. In either case, operation of any of the following protective functions shall result in the immediate separation of the on-site generation source from the MEC feeder.

AR1.1 If a protective relay with multiple set point capability is specified for the **IPR**, the multiple set point capabilities of the relay shall be utilized as indicated below.

AR1.2 ALL **IPR** systems shall consist of the following elements:

AR1.2.1 The **IPR** system shall have undervoltage (IEEE Device Function Number 27) element(s) that shall adhere to the following criteria:

- (a) An undervoltage element shall be provided for each phase. Phase-to-phase undervoltage elements are prohibited.
- (b) Single set point undervoltage elements shall operate if the monitored voltage drops below 88% of nominal for 0.5 seconds.
- (c) Multiple set point undervoltage elements shall operate in 2 seconds if the monitored voltage drops below 88% of nominal and in 0.1 second if the monitored voltage drops below 50% of nominal.

AR1.2.2 The **IPR** system shall have overvoltage (IEEE Device Function Number 59) element(s) that shall adhere to the following criteria:

- (a) An overvoltage element shall be provided for each phase. Phase-to-phase overvoltage elements are prohibited.
- (b) Single set point overvoltage elements shall operate if the monitored voltage rises above 115% of nominal for 0.5 seconds.
- (c) Multiple set point overvoltage elements shall operate in 1 second if the monitored voltage rises above 110% of nominal and in 0.1 second if the monitored voltage rises above 120% of nominal.

AR1.2.3 The **IPR** system shall have a single overfrequency (IEEE Device Function Number 81O) element that shall adhere to the following criteria:

- (a) The overfrequency element shall be set to operate if the frequency rises above 60.5 Hz.
- (b) The trip output of the overfrequency element shall be delayed by no more than 0.1 second.

		Technical Requirements for Interconnection of Generation to the MidAmerican Energy Company Distribution System (TRIMECS)	APPENDIX R
REVISION 1.0	ISSUED 05/01/05		Appendix R Page 1 of 4 TRIMECS Page 39 of 46

Appendix R: Interconnection Protective Relay (IPR) Elements Guide

AR1.2.4 The *IPR* system shall have underfrequency (IEEE Device Function Number 81U) element(s) that shall adhere to the following criteria:

- (a) Single set point underfrequency elements shall operate if the frequency drops below 59.3 Hz for 0.25 seconds.
- (b) Multiple set point underfrequency elements shall operate in 1 second if the frequency drops below 59.3 Hz and in 0.1 second if the frequency drops below 57.0 Hz.

AR1.3 For facilities whose *intended use* is other than *export*, the *IPR* system shall have directional power (IEEE Device Function Number 32) element(s).

AR1.3.1 The directional power element(s) shall adhere to the following criteria:

- (a) A directional power element shall be provided for each phase. Phase-to-phase and three phase directional power elements are not adequate.
- (b) The directional power element shall be set to operate when the power (in kW) from the on-site generation at the *facility owner's* facility is greater than 5% of the three phase kW rating of the total of aggregate generation capacity at the facility.
- (c) The trip output of the directional power element shall be delayed by no more than 2 seconds.

AR1.4 If the on-site generation at the facility has the capability to contribute 10% or more of the fault current available for a fault at the point of interconnection (as determined by the system *impact study*), the *IPR* shall have instantaneous directional overcurrent (IEEE Device Function Number 67I) element(s) designed to sense and clear faults that occur on the MEC feeder.

AR1.4.1 These instantaneous directional overcurrent element(s) shall comply with the following criteria:

- (a) An instantaneous directional overcurrent element shall be provided for each phase.
- (b) The instantaneous directional overcurrent elements shall be set to operate at 150% percent of generation full load amps at the appropriate voltage.
- (c) The trip output of the instantaneous overcurrent elements shall be delayed by no more than 0.4 seconds.

		Technical Requirements for Interconnection of Generation to the MidAmerican Energy Company Distribution System (TRIMECS)	APPENDIX R
REVISION 1.0	ISSUED 05/01/05		Appendix R Page 2 of 4 TRIMECS Page 40 of 46

Appendix R: Interconnection Protective Relay (IPR) Elements Guide

AR1.5 If the installation is interconnected with the MEC distribution system with a delta-wye transformer with the delta winding on the utility side (Note that this type of connection shall only be allowed in **EXTRAORDINARY** circumstances as determined on a case-by-case basis by MEC.), the **IPR** shall have a single zero sequence overvoltage (ANSI-IEEE Relay Function Number 59G or 59N) element that shall comply with the following criteria:

AR1.5.1 The zero sequence overvoltage element shall comply with the following criteria:

- (a) The zero sequence overvoltage element's sensing inputs shall be connected to monitor the 3V0 voltage on the utility side of the interconnection transformer, i.e. the delta side.
- (b) The sensing inputs to the zero sequence overvoltage element shall be a set of three instrument potential transformers that shall be connected grounded wye on the primary and broken corner delta on the secondary. The use of a single instrument transformer to provide zero sequence voltage sensing is prohibited.
- (c) The zero sequence overvoltage element shall be frequency compensated to respond only to the 60 Hz fundamental frequency.
- (d) The zero sequence overvoltage element shall be set to operate at 20% of nominal phase to ground potential.
- (e) The trip output of the zero sequence overvoltage element shall be delayed by no more than 0.5 seconds.

AR1.6 The requirements stated above are summarized in Table AR-1 on the following page.

		Technical Requirements for Interconnection of Generation to the MidAmerican Energy Company Distribution System (TRIMECS)	APPENDIX R
REVISION 1.0	ISSUED 05/01/05		Appendix R Page 3 of 4 TRIMECS Page 41 of 46

Appendix R: Interconnection Protective Relay (IPR) Elements Guide

Table AR-1: Summary of required relay element set points and time delays.

Element	Set Point	Time Delay
27-1	88% ¹	0.5 second ² 2 seconds
27-2	50% ¹	0.1 second
59-1	115% ^{1,2} 110% ¹	0.5 second ² 1 second
59-2	120% ¹	0.1 second
81O	60.5 Hz	0.1 second
81U-1	59.3 Hz	0.25 second ² 1 second
81U-2	57.0 Hz	0.1 second
32	5% ³	2 seconds or less
67I	150% ⁴	0.4 second or less
59N or 59G	20% ¹	0.5 second or less

Notes to Table AR-1:

¹ This setting in percent of nominal phase-to-ground potential.

² This setting applies to single set point relays only.

³ This setting in percent of the three phase kW rating of the total aggregate generation capacity.

⁴ This setting in percent of generation full load amps at the appropriate voltage.

Appendix T: Interconnection Protective Relay Discrete Test Sheet

Project Name: _____

Relay Model: _____ **Date:** _____ **Sheet 1 of 3**

Relay Element	Equivalent Setting Parameter in Relay	Setting in Relay Quantities	Tolerance in Relay Quantities	Pickup As Measured	OK?	Test Quantity
Undervoltage Relay Elements						
27-1-A		V	V	V		NA
27-1-B		V	V	V		NA
27-1-C		V	V	V		NA
27-2-A		V	V	V		NA
27-2-B		V	V	V		NA
27-2-C		V	V	V		NA
27-1 TD		S	S	S		80% of SET
27-2 TD		S	S	S		
Overvoltage Relay Elements						
59-1-A		V	V	V		NA
59-1-B		V	V	V		NA
59-1-C		V	V	V		NA
59-2-A		V	V	V		NA
59-2-B		V	V	V		NA
59-2-C		V	V	V		NA
59-1 TD		S	S	S		120% of SET
59-2 TD		S	S	S		

Comments:

	Technical Requirements for Interconnection of Generation to the MidAmerican Energy Company Distribution System (TRIMECS)	APPENDIX T
REVISION 1.0	ISSUED 05/01/05	Appendix T Page 1 of 3 TRIMECS Page 43 of 46

Appendix T: Interconnection Protective Relay Discrete Test Sheet

Project Name: _____

Relay Model: _____ **Date:** _____ **Sheet 2 of 3**

Relay Element	Equivalent Setting Parameter in Relay	Setting in Relay Quantities	Tolerance in Relay Quantities	Pickup As Measured	OK?	Test Quantity
81O		Hz	Hz	Hz		NA
81O TD		s	s	s		120% of SET
Underfrequency Relay Elements						
81U-1		Hz	Hz	Hz		NA
81U-1 TD		s	s	s		80% of SET
81U-2		Hz	Hz	Hz		NA
81U-2 TD		s	s	s		80% of SET

Comments:

	Technical Requirements for Interconnection of Generation to the MidAmerican Energy Company Distribution System (TRIMECS)	APPENDIX T
REVISION 1.0	ISSUED 05/01/05	Appendix T Page 2 of 3 TRIMECS Page 44 of 46

Appendix T: Interconnection Protective Relay Discrete Test Sheet

Project Name: _____

Relay Model: _____ **Date:** _____ **Sheet 3 of 3**

Relay Element	Equivalent Setting Parameter in Relay	Setting in Relay Quantities	Tolerance in Relay Quantities	Pickup As Measured	OK?	Relay Element
Reverse Power Element						
32-A		W	W	W		NA
32-B		W	W	W		NA
32-C		W	W	W		NA
32 TD		s	s	s		120% of SET
Instantaneous Directional Overcurrent Element						
67I-A		A	A	A		NA
67I-B		A	A	A		NA
67I-C		A	A	A		NA
67I TD		s	s	s		120% of SET
Zero Sequence Overvoltage Element						
59N		V	V	V		NA
59N TD		s	s	s		120% of SET

Comments:

	Technical Requirements for Interconnection of Generation to the MidAmerican Energy Company Distribution System (TRIMECS)	APPENDIX T
REVISION 1.0	ISSUED 05/01/05	Appendix T Page 3 of 3 TRIMECS Page 45 of 46

Appendix U: Synchronizing Device Discrete Test Sheet

Project Name: _____

Relay Model: _____ **Date:** _____ **Sheet** ___ **of** ___

Relay Element	Equivalent Setting Parameter in Relay	Setting in Relay Quantities	Tolerance in Relay Quantities	Pickup As Measured	OK?	Test Quantity
Basic Relay Elements						
Δf		Hz	Hz	Hz		NA
ΔV		V	V	V		NA
$\Delta \Phi$		°	°	°		NA
Voltage Window Elements						
27-S		V	V	V		NA
59-S		V	V	V		NA
27-B		V	V	V		NA
59-B		V	V	V		NA

Comments:

	Technical Requirements for Interconnection of Generation to the MidAmerican Energy Company Distribution System (TRIMECS)	APPENDIX U
REVISION 1.0	ISSUED 05/01/05	Appendix U Page 1 of 1 TRIMECS Page 46 of 46