

*AGRICULTURAL IMPACT MITIGATION PLAN*

# **Dakota Access Pipeline Project (DAPL)**

**Final Draft**

**State of South Dakota**

**Energy Transfer**

September 2014

Revised April 2015 in response to PUC Data Request

# CONTENTS

---

- 1 Introduction ..... 3**
- 2 Plan Limitations ..... 3**
- 3 Sequence of Construction Events and Schedule ..... 3**
- 4 Points of Contact ..... 4**
- 5 Definitions ..... 4**
- 6 Agricultural Mitigation Measures ..... 6**
  - 6.1 Clearing Brush and Trees along the Easement ..... 6
  - 6.2 Topsoil Separation and Replacement ..... 6
  - 6.3 Prevention of Erosion..... 7
  - 6.4 Aboveground Facilities..... 7
  - 6.5 Pumping Water from Open Trenches ..... 7
  - 6.6 Temporary and Permanent Repair of Drain Tiles ..... 8
  - 6.7 Removal of Rocks and Debris from the Right-of-Way ..... 10
  - 6.8 Restoration after Soil Compaction and Rutting ..... 10
  - 6.9 Restoration of Terraces, Waterways and other Erosion Control Structures ..... 10
  - 6.10 Revegetation of Untilled Land..... 11
  - 6.11 Future Drain Tiles and Soil Conservation Structure Installation ..... 11
  - 6.12 Restoration of Land Slope and Contour ..... 11
  - 6.13 Siting and Restoration of Areas Used for Field Entrances and Temporary Roads ..... 11
  - 6.14 Construction in Wet Conditions..... 11
- 7 Compensation for Damages..... 12**

**Appendices**

A Tile Repair Drawings

**Acronyms and Abbreviations**

DAPL Dakota Access Pipeline, LLC (Project Sponsor)  
 EI/AI Environmental Inspector/Agricultural Inspector

# 1 INTRODUCTION

---

Dakota Access Pipeline, LLC (DAPL) is planning a new 30-inch pipeline to transport crude oil from the Bakken Shale region of North Dakota to Illinois. The eastern terminus of the pipeline will connect with an existing pipeline that will transport the crude oil to the Gulf Coast for processing.

The South Dakota section of the pipeline comprises a 277-mile corridor that will run from north central South Dakota to southeast South Dakota. The proposed pipeline will enter South Dakota in Campbell County and diagonally traverse the state, exiting at the crossing of the Big Sioux River in Lincoln County, South Dakota.

The purpose of this document is to present the proposed measures for minimizing impacts to and restoring agricultural lands during and after pipeline construction.

## 2 PLAN LIMITATIONS

---

Mitigation measures identified in this plan apply only to agricultural land and do not apply to urban land, road and railroad right-of-way, interstate natural gas pipelines, mined and disturbed land not used for agriculture. The identified mitigation measures will be implemented as long as they do not conflict with federal, state, and local permits, approvals and regulations.

## 3 SEQUENCE OF CONSTRUCTION EVENTS AND SCHEDULE

---

Pipeline construction is anticipated to commence Spring of 2016 following the receipt of required permits and approvals. Pipeline construction will take approximately 9 months to complete.

The sequence of events for pipeline construction will begin with advance notification of landowners and governmental agencies. Following notification, activities will be undertaken in the following sequence:

- Complete final surveys, stake centerline and workspace;
- Access road installation;
- Grubbing and clearing of the construction corridor;
- Installation of stormwater and erosion control measures;
- Placement of pipe and other supplies along the construction corridor;
- Pipeline welding and bending where necessary
- Excavation of the pipeline trench;
- Temporary repairs to tile lines, if encountered;
- Placement of the pipeline with the trench;
- Permanent repairs to tile lines damaged during construction activities;
- Backfill of the trench and rough grading,
- Hydrostatic testing of the pipeline;
- Final grading and restoration;
- Revegetation and post restoration monitoring; and
- Removal of erosion control measures.

## 4 POINTS OF CONTACT

---

Each landowner will be provided the name, telephone number, email address, and mailing address of the DAPL landowner representative two weeks prior to construction. This DAPL representative will be the primary contact person for the landowner throughout construction for easement issues. Landowner representatives will be assigned to that geographic area and be responsible for the liaison activities on behalf of DAPL.

In addition to the landowner representative, a team of experienced Environmental and/or Agricultural Inspectors (EIs/AIs), will be involved in project construction, the initial restoration, and the post-construction monitoring and follow-up restoration.

## 5 DEFINITIONS

---

Agricultural Land	Land that is actively managed for cropland, hayland or pasture and land in government set-aside programs.
Cropland	Land actively managed for growing row crops, small grains or hay.
Drainage Structures or Underground Improvements	Any permanent structure used for draining agricultural lands, including tile systems and buried terrace outlets.
Easements	The agreement(s) and/or interest in privately owned Agricultural Land held by DAPL by virtue of which it has the right to construct, operate and maintain the pipeline together with such other rights and obligations as may be set forth in such agreement.
Environmental Construction Plan (ECP)	Document to present basic environmental construction techniques will be implemented to protect the environment and to minimize potential effects of pipeline and related facilities construction and maintenance.
Pipeline	Any pipe, pipes, or pipelines used for the transportation or transmission of any solid, liquid, or gaseous substance, except water, in

	intrastate or interstate commerce.
Landowner	Person listed on the tax assessment rolls as responsible for the payment of real estate taxes imposed on the property.
Non-Agricultural Land	Any land that is not "Agricultural Land" as defined above.
Pipeline Construction	A substantial disturbance to agricultural land associated with installation, replacement, removal, operation or maintenance of a pipeline.
Soil Conservation Practices	Any land conservation practice recognized by federal or state soil conservation agencies including, but not limited to, grasslands and grassed waterways, hay land planting, pasture, and tree plantings.
Soil Conservation Structures	Any permanent structure recognized by federal or state soil conservation agencies including but not limited to toe walls, drop inlets, grade control works, terraces, levees, and farm ponds.
Right-of-Way (ROW)	Includes the permanent and temporary easements that DAPL acquires for the purpose of constructing and operating the Pipeline.
Tenant	Any person lawfully residing on or in possession of the land, which makes up the "Right-of-Way" (ROW) as defined in this Plan.
Tile	Any artificial subsurface drainage system including clay and concrete, tile, vitrified sewer tile, corrugated plastic tubing and stone drains.
Till	Till is to loosen the soil in preparation for planting or seeding by plowing, chiseling, disking, or similar means. Agricultural land planted using no-till planting practices is also considered tilled.
Topsoil	The upper part of the soil which is the most favorable material for plant growth and which can ordinarily be distinguished from subsoil by its higher organic content and darker color.
Surface Drains	Any surface drainage system such as shallow surface field drains, grassed waterways, open

---

	ditches, or any other constructed facilities for the conveyance of surface water.
--	-----------------------------------------------------------------------------------

---

## 6 AGRICULTURAL MITIGATION MEASURES

---

The following describes how DAPL proposes to minimize and repair impacts to agricultural lands.

### a. CLEARING BRUSH AND TREES ALONG THE EASEMENT

DAPL will be responsible for negotiating compensation related to cutting of any brush and timber for construction of the pipeline with the landowner. Options for removal include: the landowner harvesting any marketable timber/vegetation, the contractor cutting and windrowing along the ROW for Landowner's use, chipped, burned, or hauled off for proper disposal. Unless otherwise restricted by federal, state or local regulations and to the extent that the requests are deemed reasonable, DAPL will follow Landowner's easement agreement regarding the removal of tree stumps and disposal of trees, brush, and stumps of no value to the landowner. Methods of disposal can include, but are not limited to, burning, chipping, or removal from the property and be approved by the DAPL representative and coordinated with the landowner prior to implementation.

Unless otherwise restricted by federal, state or local regulations and to the extent that the requests are deemed reasonable, DAPL will follow Landowner's easement agreement regarding the removal of tree stumps and disposal of trees, brush, and stumps of no value to the landowner. Methods of disposal can include, but not limited to burning, chipping or completed removal from the property and be approved by the DAPL Chief Inspector & Lead Environmental Inspector prior to implementation.

### b. TOPSOIL SEPARATION AND REPLACEMENT

Topsoil and subsoil excavated for pipeline installation will be separated and segregated in separate stockpiles, and returned to the excavation in reverse order to restore the site to pre-construction condition. The depth of the topsoil to be stripped will be a maximum depth of 12 inches or actual depth of top soil if less than 12 inches or as agreed upon with the landowner. Upon request from the landowner, DAPL will measure topsoil depth at selected locations before and after construction.

The stored topsoil and subsoil will have sufficient separation to prevent mixing during the storage period. Topsoil will not be used to construct field entrances or drives, will not be stored or stockpiled at locations that will be used as a traveled way by construction, or be removed from the property, without the written consent of the landowner. Drainage gaps in the topsoil and subsoil piles will be left to avoid blocking drainage across the right of way.

Topsoil will not be removed where the pipeline is installed by plowing, jacking, boring, or other methods that do not require the opening of a trench.

The topsoil will be replaced so the upper portion of the pipeline excavation and the crowned surface, and the cover layer of the area used for subsoil storage, contains only the topsoil originally removed.

In most areas, ditch-line crowns will be installed to allow for and counter-act ditch settling. In the event the landowner will not allow a ditch-line crown, DAPL may have to regrade the right of way in

subsequent growing season. In this situation, DAPL may regrade the construction right of way and till down to 12 inches to manipulate the soil such that the original contours and elevation are restored. The depth of the replaced topsoil will conform as nearly as possible to the depth removed. Where excavations are made for road, stream, drainage ditch, or other crossings, the original depth of topsoil will be replaced as nearly as possible.

### **c. PREVENTION OF EROSION**

DAPL will follow best management practices and industry standards for erosion and sedimentation control during construction and post-construction. DAPL will develop a Storm Water Pollution Prevention Plan (SWPPP). The SWPPP will detail the project specific stormwater and soil erosion prevention measures. In addition to the SWPPP stipulations, all of the regulations and conditions associated with the required South Dakota DNR NPDES permit will require the Contractor's full compliance. An approved SWPPP and South Dakota DNR NPDES permit will be required before any earth disturbing construction activities can take place.

### **d. ABOVEGROUND FACILITIES**

The location for any aboveground structures will be selected in coordination with respective landowners. If use of agricultural land use is appropriate and/or necessary, aboveground structures will be located in a manner to minimize interference with agricultural operations. Compensation for aboveground structures will be negotiated as part of landowner compensation.

### **e. PUMPING WATER FROM OPEN TRENCHES**

Trench and/or pit dewatering is necessary due to accumulation of precipitation and/or groundwater in open trenches; the Contractor will locate discharges within the Project ROW whenever feasible to avoid potential impacts to adjacent areas. Should a discharge need to occur outside of the ROW, prior landowner approval will be obtained and the area will be restored to pre-construction conditions. Pumping will occur in a manner that will avoid damaging adjacent agricultural land, crops, and/or pasture. Erosion and sedimentation control measures will be implemented and may include the use of dewatering structures, splash plates, sediment bags, haybales, and silt fence. The removal and disposal of trench water will comply with applicable drainage laws and local ordinances relating to such activities as well as provisions of the federal Clean Water Act.

Prior to initiating dewatering activities, the EI must check the water discharge situation to ensure that the best management practices are applied in such a way to avoid erosion and sedimentation offsite.

At each location where dewatering is to be conducted, the contractor must consider the following conditions in planning the dewatering event.

**a. Water Discharge Setting** – The contractor shall assess each water discharge situation to include:

- (1) Soil Type - The soil type the discharged water would flow over. The management of discharged water traveling over sandy soil is more likely to soak into the ground as compared to clay soils.
- (2) Ground Surface - The topography in the area that would influence the surface flow of the discharged water.

- (3) Adjustable Discharge Rate - The flow rate of the discharged water (which may need to vary) can be managed based on the site conditions to minimize instances of water from reaching a sensitive resource area such as a wetland or waterbody. (Example - Water discharged at 500 gallons per minute may soak into the ground while if discharged at a higher flow rate would cause water to flow via overland runoff into a sensitive resource area)
- (4) Discharge Outfall - The amount of hose and number/size of pumps needed to attempt to discharge water at a location, which drains away from waterbodies or wetlands.

b. **Pump Intake** - Use floating suction hose or other similar measures to prevent sediment from being sucked from bottom of trench.

c. **Overwhelming Existing Drainage** - If the discharge (assumed to be clean) does enter a stream, the flow added to the stream cannot exceed 50 percent of the peak storm event flow (to prevent adding high water volumes to a small stream channel that causes erosion due to imposing high flow conditions on the stream).

d. **Filtering Mechanism**

- (1) All dewatering discharges will be directed through a filtering device as indicated below.
  - i) Well-Vegetated Upland Area – Water can be directed to a well-vegetated upland area through a geotextile filter bag. Geotextile bags need to be sized appropriately for the discharge flow and suspended sediment particle size.
  - ii) Straw Bale Dewatering Structure – Where the dewatering discharge point cannot be located in an upland area due to site conditions and/or distance, the discharge should be directed into a straw bale dewatering structure. The size of the straw bale dewatering structure is dependent on the maximum water discharge rate. A straw bale dewatering structure should be used in conjunction with a geotextile filter bag to provide additional filtration near sensitive resource areas.
  - iii) Alternative dewatering methods (e.g., use of water cannons) may be approved by DAPL on a site-specific basis.

**f. TEMPORARY AND PERMANENT REPAIR OF DRAIN TILES**

The following methods for repair of drain tiles are proposed:

- a. **Movement of Drain Tiles before Construction:** DAPL will install with landowner consent parallel tile drains along the proposed right-of-way in advance of pipeline construction to maintain the drainage of the field tile drain system. After construction, the parallel tile drains will be connected across the pipeline right-of-way to facilitate a re-united overall tile drain system in the agricultural field.
- b. **Pipeline Clearance from Drain Tile:** Where underground drain tile is encountered within in the project profile, the pipeline will be installed in such a manner that the permanent tile repair



can be installed with at least 24 inches of clearance from the pipeline or as agreed upon with landowner.

- c. **Temporary Repair:** The following standards will be used to determine if temporary repair of agricultural drainage tile lines encountered during pipeline construction is required.
  - (1) Any underground drain tile damaged, cut, or removed and found to be flowing or which subsequently begins to flow will be temporarily repaired as soon as practicable, and the repair will be maintained as necessary to allow for its proper function during construction of the pipeline. The temporary repairs will be maintained in good condition until permanent repairs are made.
  - (2) If tile lines are dry and water is not flowing, temporary repairs are not required if the permanent repair is made within ten days of the time the damage occurred.
  - (3) Temporary repair is not required if the angle between the trench and the tile lines places the tile end points too far apart for temporary repair to be practical.
  - (4) If temporary repair of the line is not made, the upstream exposed tile line will not be obstructed but will nonetheless be screened or otherwise protected to prevent the entry of foreign materials and small animals into the tile line system, and the downstream tile line entrance will be capped or filtered to prevent entry of mud or foreign material into the line if the water level rises in the trench.
- d. **Marking:** Any underground drain tile damaged, cut, or removed will be marked by placing a highly visible flag in the trench spoil bank directly over or opposite such tile. This marker will not be removed until the tile has been permanently repaired.
- e. **Permanent Repairs:** Tile disturbed or damaged by pipeline construction will be repaired to its original or better condition. Permanent repairs will be completed as soon as is practical after the pipeline is installed in the trench and prior to backfilling of the trench over the tile line. Permanent repair and replacement of damaged drain tile will be performed in accordance with the following requirements:
  - (1) All damaged, broken, or cracked tile will be removed.
  - (2) Only unobstructed tile will be used for replacement.
  - (3) The tile furnished for replacement purposes will be of a quality, size and flow capacity at least equal to that of the tile being replaced.
  - (4) Tile will be replaced so that its original gradient and alignment are restored, except where relocation or rerouting is required for angled crossings. Tile lines at a sharp angle to the trench will be repaired in the manner shown in Appendix A.
  - (5) The replaced tile will be firmly supported to prevent loss of gradient or alignment due to soil settlement. The method used will be comparable to that shown in Appendix A.
  - (6) Before completing permanent tile repairs, all tile lines will be examined visually, by probing, or by other appropriate means on both sides of the trench within any work area to check for tile that might have been damaged by construction equipment. If tile lines are found to be damaged, they must be repaired to operate as well after construction as before construction began.

- f. **Inspection:** Prior to backfilling of the applicable trench area, each permanent tile repair will be inspected for compliance by the DAPL Tile Inspector.
- g. **Backfilling:** The backfill surrounding the permanently repaired drain tile will be completed at the time of the repair and in a manner that ensures that any further backfilling will not damage or misalign the repaired section of the tile line.
- h. **Subsurface Drainage:** Subsequent to pipeline construction and permanent repair, if it becomes apparent the tile line in the area disturbed by construction is not functioning correctly or that the land adjacent to the pipeline is not draining properly, which can reasonably be attributed to the pipeline construction, DAPL will make further repairs or install additional tile as necessary to restore subsurface drainage.

**g. REMOVAL OF ROCKS AND DEBRIS FROM THE RIGHT-OF-WAY**

Excess rocks will be removed from the right-of-way. On completion, the topsoil in the easement area will be free of all rocks larger than three inches in average diameter that are not native to the topsoil prior to excavation, and similar to adjacent soil not disturbed by construction. The top 24 inches of the trench backfill will not contain rocks in any greater concentration or size than exist in the adjacent natural soils. Consolidated rock removed by blasting or mechanical means shall not be placed in the backfill above the natural bedrock profile or above the frost line. In addition, DAPL will examine areas adjacent to the easement and along access roads and will remove any large rocks or debris that may have rolled or blown from the right-of-way or fallen from vehicles.

Rock that cannot remain in or be used as backfill will be disposed of at locations and in a manner mutually satisfactory to the company’s environmental inspector and the landowner. All debris attributable to the pipeline construction and related activities will be removed and disposed of properly; such debris includes spilled oil, grease, fuel, or other petroleum or chemical products. Such products and any contaminated soil will be removed for proper disposal or treated by appropriate in situ remediation.

**h. RESTORATION AFTER SOIL COMPACTION AND RUTTING**

Agricultural land compacted by heavy project equipment, including off right-of-way access roads, will be deep tilled to alleviate soil compaction upon completion of construction on the property. In areas where topsoil was removed, tillage will precede replacement of topsoil. At least three passes with the deep tillage equipment shall be made. Tillage shall be at least 18 inches deep in land used for crop production and 12 inches deep on other lands,(except where shallow tile systems are encountered), and shall be performed under soil moisture conditions which permits effective working of the soil. If agreed in advance, this tillage may be performed by the landowners or tenants using their own equipment.

Rutted land will be graded and tilled until restored as near as practical to its preconstruction condition. On lands where topsoil was removed, rutting will be remedied before topsoil is replaced.

**i. RESTORATION OF TERRACES, WATERWAYS AND OTHER EROSION CONTROL STRUCTURES**

Existing soil conservation practices and structures damaged by pipeline construction, such as surface drains, embankments and terraces, grass waterways will be restored to pre-construction elevation, grade and condition. Any drain lines or flow diversion devices impacted by pipeline construction will be

repaired or modified as needed. Soil used to repair embankments intended to retain water shall be well compacted. Disturbed vegetation will be reestablished, including a cover crop when appropriate. Restoration of terraces will be in accordance with Standard Drawings in Appendix A.

#### **j. REVEGETATION OF UNTILLED LAND**

Agricultural land not in row crop or small grain production at the time of construction, such as hay fields and land in conservation or set-aside programs, will be reseeded following completion of deep tillage and replacement of the topsoil. The seed mix used will restore the original or a comparable ground cover unless otherwise requested by the landowner.

Land that is normally used for crops that will not be planted due to pipeline construction will be seeded with an appropriate cover crop following replacement of the topsoil and completion of deep tillage, unless otherwise agreed to with the landowner. Cover crop seeding may be delayed if construction is completed too late in the year for a cover crop to establish and in such instances is not required if the landowner or tenant proposed to till the land the following year.

#### **k. FUTURE DRAIN TILES AND SOIL CONSERVATION STRUCTURE INSTALLATION**

At locations where future drain tile or soil conservation practices and structures are made known to DAPL in writing prior to securing the easement on the property, the pipeline will be installed at a depth that will permit proper clearance between the pipeline and the proposed tile installation, or allow for proper installation of the conservation practices. DAPL will consult with the landowner concerning the landowner's plans for these future actions.

#### **l. RESTORATION OF LAND SLOPE AND CONTOUR**

The slope, contour, grade, and drainage pattern of the disturbed area will be restored as nearly as possible to its preconstruction condition. However, the trench may be crowned to allow for anticipated settlement of the backfill. DAPL will remediate areas of excessive or insufficient settlement in the trench area where it visibly affects land contour or alters surface drainage. Disturbed areas where erosion causes excessive rills or channels or areas of heavy sediment deposition, will be regraded as needed. On steep slopes, methods such as sediment barriers, slope breakers, or mulching will be used as necessary to control erosion until vegetation can be reestablished.

#### **m. SITING AND RESTORATION OF AREAS USED FOR FIELD ENTRANCES AND TEMPORARY ROADS**

The location of temporary roads to be used for construction purposes will be negotiated with the landowner and the Tenant. The temporary roads will be designed to not impede proper drainage and will be built to minimize soil erosion on or near the temporary roads.

Post construction and restoration temporary field entrances or access roads will be removed and the land made suitable for its previous use, in agreement with the landowner. Areas affected will be regraded and deep tilled as required. If by agreement or at landowner request, and approved by local public road authorities, a field entrance or road is left in place, it will be left in a graded and serviceable condition.

#### **n. CONSTRUCTION IN WET CONDITIONS**

Construction in wet soil conditions will not commence or continue at times when or locations where the passage of heavy construction equipment may cause rutting to the extent that the topsoil and subsoil are mixed, or underground drainage structures may be damaged. To facilitate construction in soft soils, DAPL may elect to remove and stockpile the topsoil from the traveled way, install mats or padding, or use other methods.

## **7 COMPENSATION FOR DAMAGES**

---

DAPL will be responsible for compensating the landowner for damages during construction. For crops, value of the loss will be established based on current crop values in the area of the impact per South Dakota Department of Agriculture statistics. DAPL will also compensate the landowner for loss of use of agricultural land, if attributable to pipeline construction. Supplemental soil sampling, testing and additional restoration activities to restore agricultural land to its pre-construction conditions will be undertaken by DAPL upon request of the landowner.

DAPL will also be responsible to compensate landowners for other physical property damage attributable to pipeline construction, such as fences, driveways and other structures.

## **Appendix A**

### **Tile Repair Drawings**

---

**FIGURE 1.**

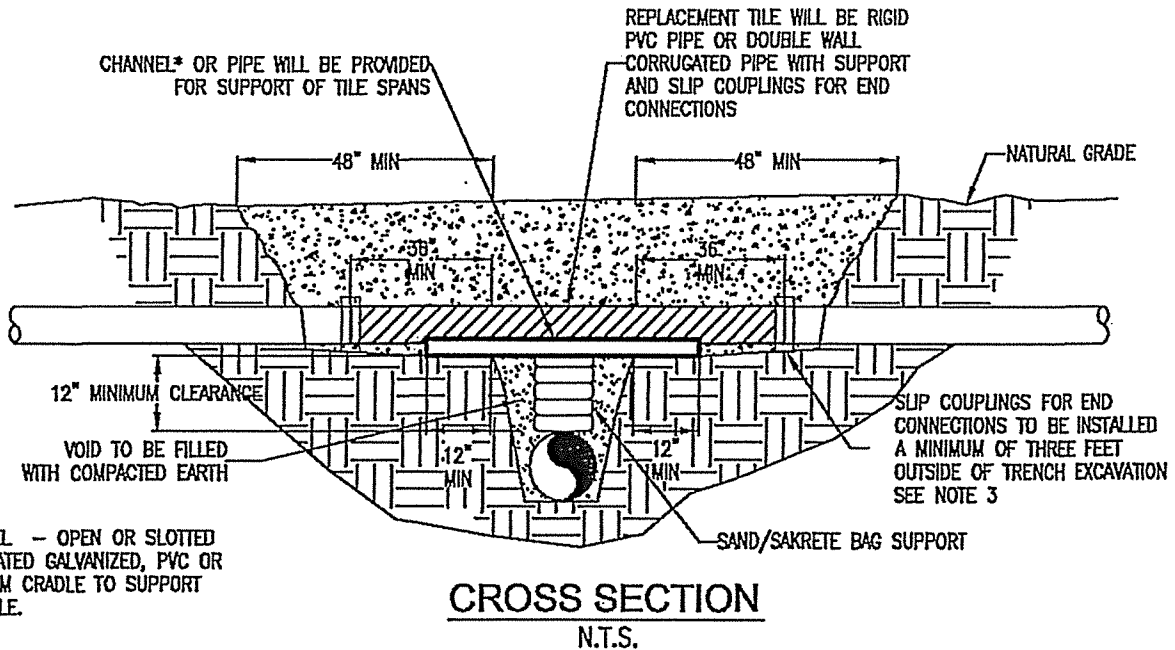
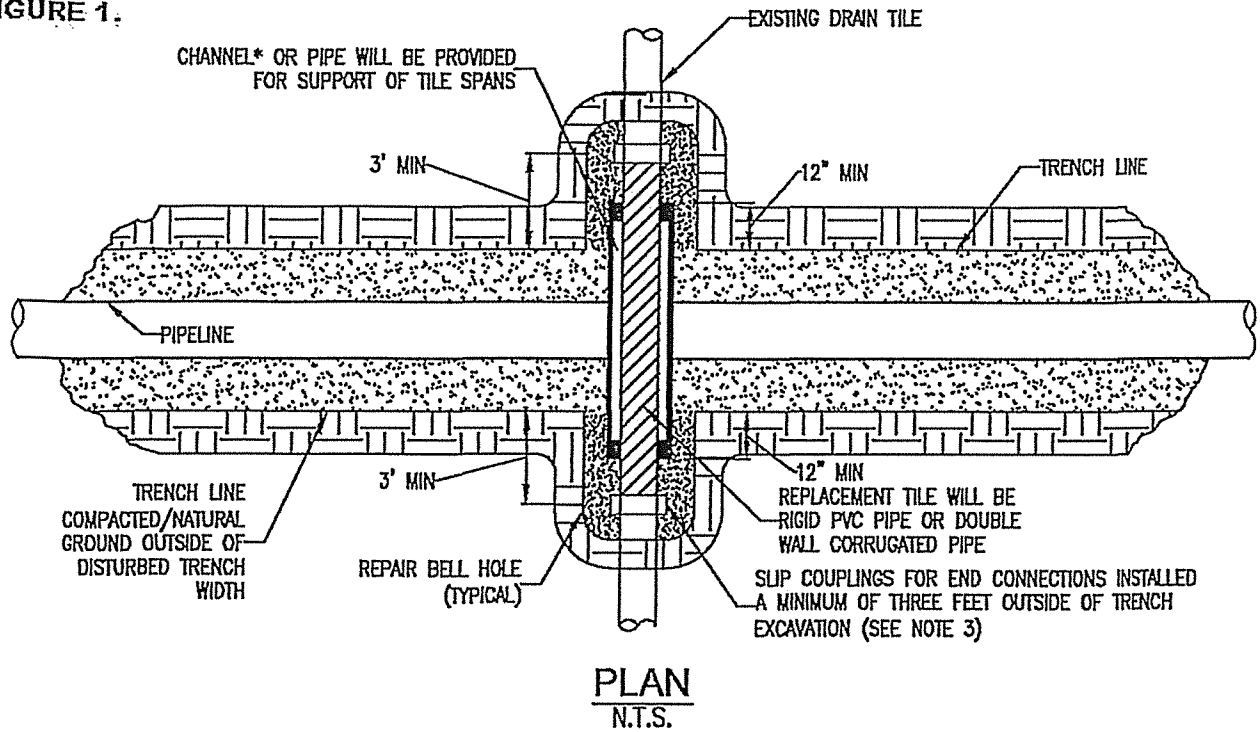

\*CHANNEL - OPEN OR SLOTTED CORRUGATED GALVANIZED, PVC OR ALUMINUM CRADLE TO SUPPORT DRAIN TILE.

**NOTE:**

1. IMMEDIATELY REPAIR TILE IF WATER IS FLOWING THROUGH TILE AT TIME OF TRENCHING. IF NO WATER IS FLOWING AND TEMPORARY REPAIR IS DELAYED, OR NOT MADE BY THE END OF THE WORK DAY, A SCREEN OR APPROPRIATE 'NIGHT CAP' SHALL BE PLACED ON OPEN ENDS OF TILE TO PREVENT ENTRAPMENT OF ANIMALS ETC.
2. CHANNEL OR PIPE (OPEN OR SLOTTED) MADE OF CORRUGATED GALVANIZED PIPE, PVC OR ALUMINUM WILL BE USED FOR SUPPORT OF DRAIN TILE SPANS.
3. INDUSTRY STANDARDS SHALL BE FOLLOWED TO ENSURE PROPER SEAL OF REPAIRED DRAIN TILES.

**FIGURE 2.**

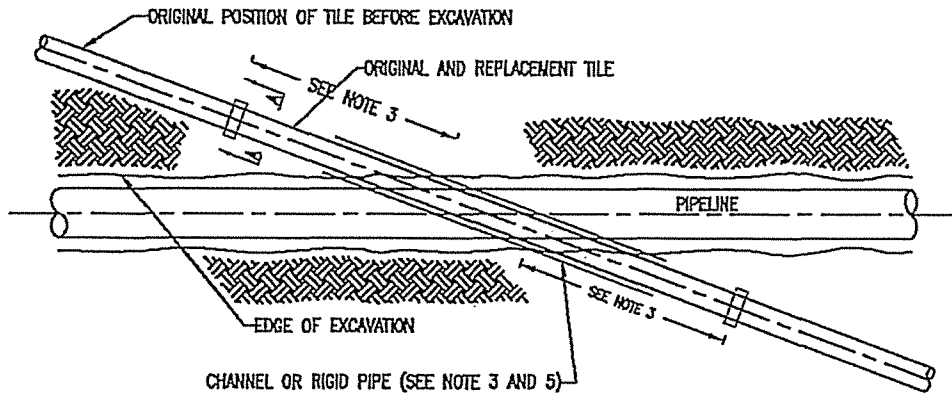

**PLAN VIEW**

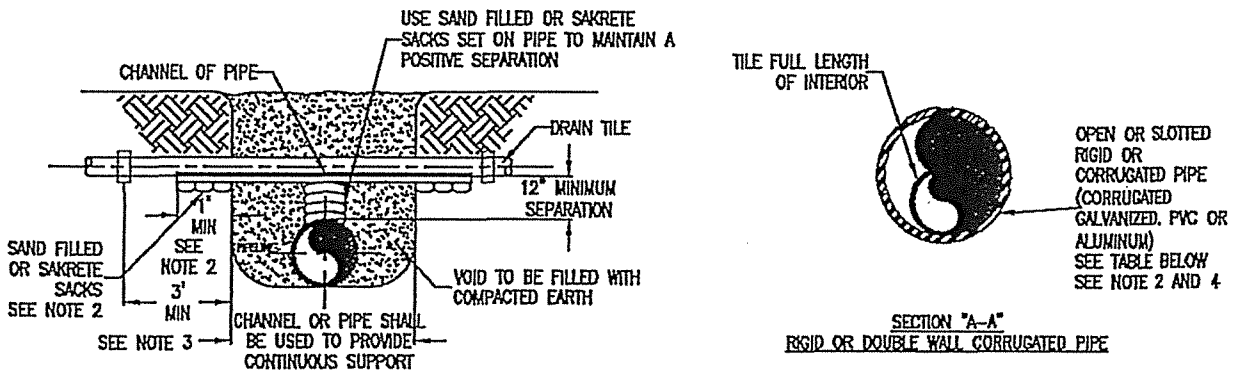

**END VIEWS**

MINIMUM SUPPORT TABLE			
TILE SIZE	CHANNEL SIZE	PIPE SIZE	
3"	4" @ 5.4 #11	4"	STD. WT.
4"-5"	5" @ 6.7 #11	6"	STD. WT.
8"-9"	7" @ 9.8 #11	9"-10"	STD. WT.
10"	10" @ 15.3 #11	12"	STD. WT.

**NOTE:**

1. TILE REPAIR AND REPLACEMENT SHALL MAINTAIN ORIGINAL ALIGNMENT GRADIENT AND WATER FLOW TO THE GREATEST EXTENT POSSIBLE. IF THE TILE NEEDS TO BE RELOCATED, THE INSTALLATION ANGLE MAY VARY DUE TO SITE SPECIFIC CONDITIONS AND LANDOWNER RECOMMENDATIONS.
2. 1'-0" MINIMUM LENGTH OF CHANNEL OR RIGID PIPE (OPEN OR SLOTTED CORRUGATED GALVANIZED, PVC OR ALUMINUM CRADLE) SHALL BE SUPPORTED BY UNDISTURBED SOIL, OR IF CROSSING IS NOT AT RIGHT ANGLES TO PIPELINE, EQUIVALENT LENGTH PERPENDICULAR TO TRENCH. SHIM WITH SAKRETE, OR SAND BAGS TO UNDISTURBED SOIL FOR SUPPORT AND DRAINAGE GRADIENT MAINTENANCE (TYPICAL BOTH SIDES).
3. DRAIN TILES WILL BE PERMANENTLY CONNECTED TO EXISTING DRAIN TILES A MINIMUM OF THREE FEET OUTSIDE OF EXCAVATED TRENCH LINE USING INDUSTRY STANDARDS TO ENSURE PROPER SEAL OF REPAIRED DRAIN TILES INCLUDING SLIP COUPLINGS.
4. DIAMETER OF RIGID PIPE SHALL BE OF ADEQUATE SIZE TO ALLOW FOR THE INSTALLATION OF THE TILE FOR THE FULL LENGTH OF THE RIGID PIPE.
5. OTHER METHODS OF SUPPORTING DRAIN TILE MAY BE USED IF ALTERNATE PROPOSED IS EQUIVALENT IN STRENGTH TO THE CHANNEL/PIPE SECTIONS SHOWN AND IF APPROVED BY COMPANY REPRESENTATIVES AND LANDOWNER IN ADVANCE. SITE SPECIFIC ALTERNATE SUPPORT SYSTEM TO BE DEVELOPED BY COMPANY REPRESENTATIVES AND FURNISHED TO CONTRACTOR FOR SPANS IN EXCESS OF 20', TILE GREATER THEN 10" DIAMETER, AND FOR "HEADER" SYSTEMS.
6. ALL MATERIAL TO BE FURNISHED BY CONTRACTOR.
7. PRIOR TO REPAIRING TILE, CONTRACTOR SHALL PROBE LATERALLY INTO THE EXISTING TILE TO FULL WIDTH OF THE RIGHTS OF WAY TO DETERMINE IF ADDITIONAL DAMAGE HAS OCCURRED. ALL DAMAGED/DISTURBED TILE SHALL BE REPAIRED AS NEAR AS PRACTICABLE TO ITS ORIGINAL OR BETTER CONDITION.

DRAIN TILE	HEADER SIZE	SPACING "L"
4"	TBD	TBD
6"	TBD	TBD
8"	TBD	TBD
10"	TBD	TBD

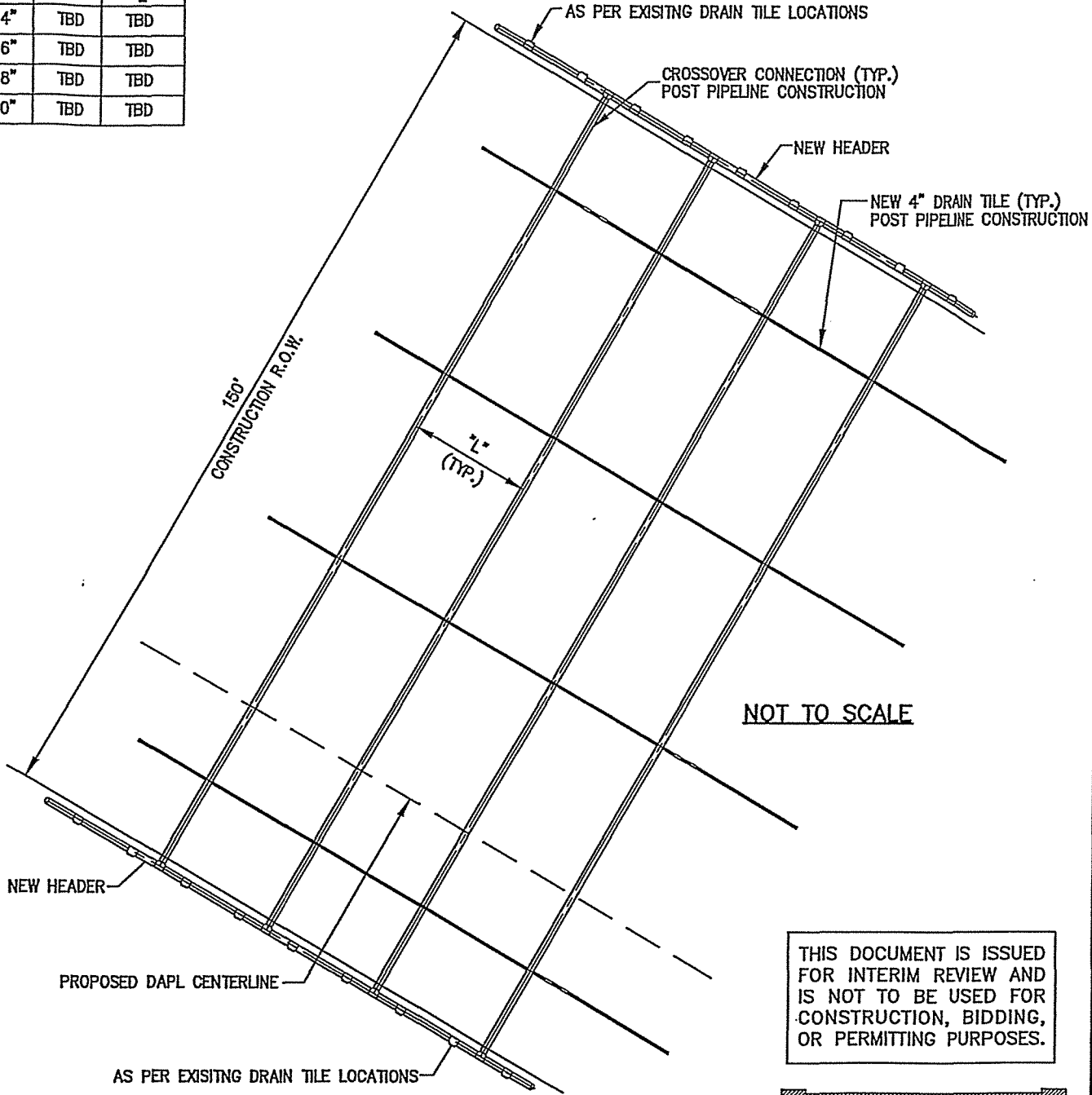

NOT TO SCALE

THIS DOCUMENT IS ISSUED FOR INTERIM REVIEW AND IS NOT TO BE USED FOR CONSTRUCTION, BIDDING, OR PERMITTING PURPOSES.

ISSUED FOR REVIEW  
09/02/14

- NOTES:
- HEADERS WILL BE CONNECTED TO EXISTING DRAIN TILE PRE-CONSTRUCTION.
  - CROSSOVER PIPING WILL BE INSTALLED POST PIPELINE INSTALLATION.

# DAPL/ETCOP

## TYPICAL DRAIN TILE HEADER SYSTEM

REV.	DATE	BY	DESCRIPTION	CHK.
A	9/2/14	DAH	ISSUED FOR REVIEW	
PROJECT NO.			10395700	

DRAWN BY: DAH	DATE: 09/02/14	DWG. NO.	REV.
CHECKED BY: DAH	DATE: 09/02/14	P12-49	A
SCALE: N.T.S.	APP.:		