

Qwest Corporation
Access Service
Tariff

SECTION 2

Page 50

Release 3

State of South Dakota
Issued: 05-26-2017

Effective: 07-01-2017

2. GENERAL REGULATIONS

2.4 PAYMENT ARRANGEMENTS AND CREDIT ALLOWANCES

2.4.7 ORDERING, RATING AND BILLING OF ACCESS SERVICES WHERE MORE THAN ONE EXCHANGE TELEPHONE COMPANY IS INVOLVED (Cont'd)

- D. When jointly provisioned Switched Access Service is provided between the Company and another Exchange Telephone Company, the appropriate Switched Access recurring rates will be applied based on the type of Switched Transport provided, Tandem-Switched Transport (TST) or Direct-Trunked Transport (DTT). Tandem 3rd Party rates apply to Terminating Traffic Types between the Company and another Exchange Telephone Company that is not a CenturyLink Operating Company (CLOC) ILEC. (C)

For Switched Access Service provisioned as TST, the appropriate Switched Access recurring rates for Terminating – Tandem 3rd Party or Originating will be applied as follows: 1) multiply the Tandem Transmission fixed rate by the minutes of use (MOU) by the billing percentage (BP), 2) multiply the Tandem Transmission per-mile rate by the number of miles, by the MOU by the BP, and 3) all other appropriate Switched Access recurring rate elements at 100 percent, if applicable. (C)

For Switched Access Service provisioned as DTT, the recurring rates will be applied as follows: 1) multiply the monthly Transport Channel fixed rate by the BP, 2) multiply the monthly Transport Channel per-mile rate by the number of miles, by the BP, and 3) all other appropriate Switched Access recurring rate elements at 100 percent, if applicable.

The Exchange Telephone Company that owns the access tandem will assess the appropriate access tandem Terminating – Tandem 3rd Party or Originating recurring rates at 100 percent. The Exchange Telephone Company that owns the end office will assess the appropriate end office recurring rates at 100 percent. (C)

- E. When jointly provisioned Switched Access Service is provided and the Company is the intermediate non-terminating carrier, only the recurring Tandem Transmission per-mile rate for Terminating – Tandem 3rd Party or Originating or DTT per-mile rate will apply. The Tandem Transmission Originating Tandem Transmission Terminating – Tandem 3rd Party per-mile rate or DTT per-mile rate will be determined by multiplying the appropriate rate by the MOU by the number of miles, by the BP. The DTT per-mile rate will be determined by multiplying the appropriate DTT per-mile monthly rate by the number of miles by the BP. If the Company provides the access tandem, all appropriate access tandem 3rd Party recurring rates will apply at 100 percent. (C)

- F. When jointly provisioned access service is provided between the Company and another Exchange Telephone Company, or when the Company is the intermediate non-terminating carrier, the appropriate nonrecurring charges shall apply. The BP is not applied to nonrecurring charges. (C)

**Qwest Corporation
Access Service
Tariff**

SECTION 2
Page 51
Release 3
Effective: 07-01-2017

State of South Dakota
Issued: 05-26-2017

2. GENERAL REGULATIONS

2.4 PAYMENT ARRANGEMENTS AND CREDIT ALLOWANCES

2.4.7 ORDERING, RATING AND BILLING OF ACCESS SERVICES WHERE MORE THAN ONE EXCHANGE TELEPHONE COMPANY IS INVOLVED (Cont'd)

G. Examples - Switched Access provisioned by Direct Trunked Transport and Tandem-Switched Transport

(T)

Feature Group D Access Service Ordered

(C)

Example 1

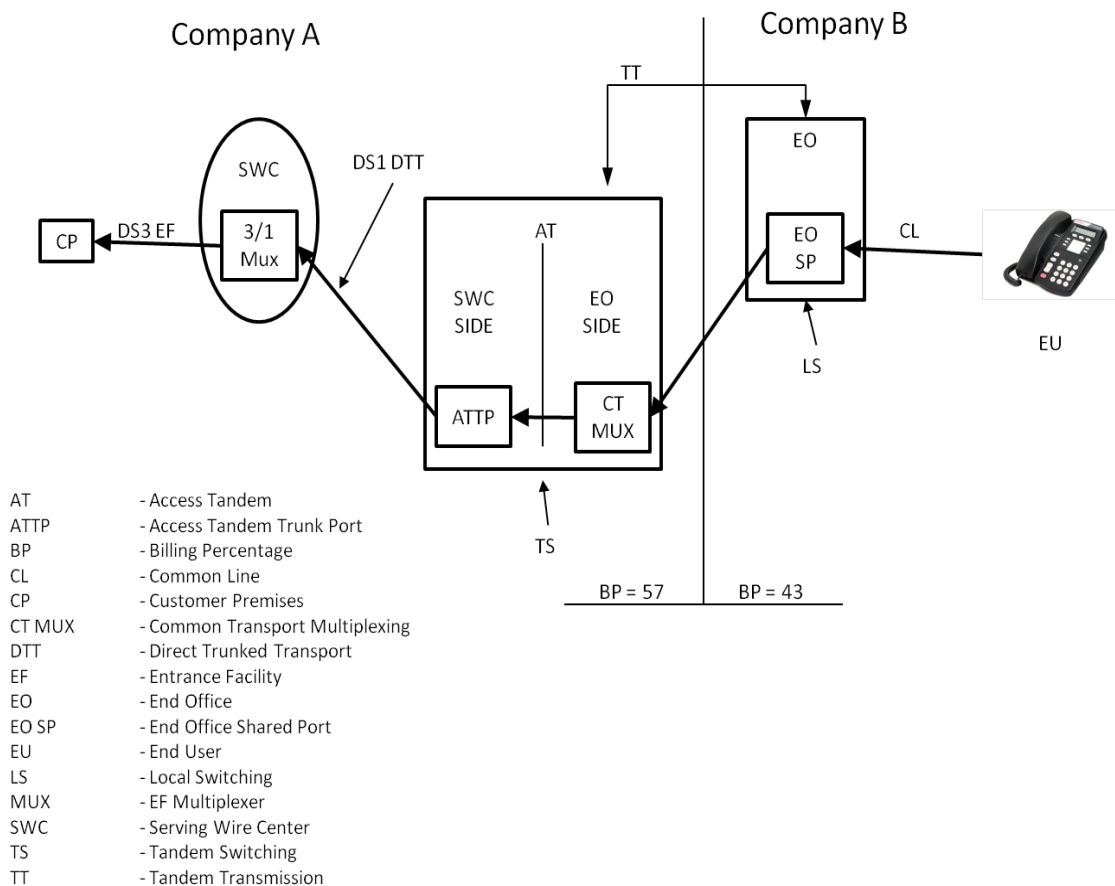

(C)

Qwest Corporation
Access Service
Tariff

SECTION 2

Page 52

Release 3

State of South Dakota
Issued: 05-26-2017

Effective: 07-01-2017

2. GENERAL REGULATIONS

2.4 PAYMENT ARRANGEMENTS AND CREDIT ALLOWANCES

2.4.7 ORDERING, RATING AND BILLING OF ACCESS SERVICES WHERE MORE THAN ONE EXCHANGE TELEPHONE COMPANY IS INVOLVED

- G. Examples - Switched Access provisioned by Direct Trunked Transport and Tandem-Switched Transport (Cont'd) (T)
1. Example 1 Layout (C)
 - a. Originating Feature Group D Switched Access is ordered to an end office via DTT and TST. Originating rates would apply. (C)
(C)
 - b. The premises of ordering customer, the serving wire center (SWC) of that premises, and the access tandem are in operating territory of Company A. (C)
 - c. The customer orders a DS3 Entrance Facility from the customer's premises to the SWC with a 3/1 MUX in the SWC.
 - d. The customer orders a DS1 DTT to the AT.
 - e. The BP for TT is 57 for Company A. (C)
 - f. The end office is in the operating territory of Company B. (C)
 - g. The BP for transport is 43 for Company B. (C)

Qwest Corporation
Access Service
Tariff

SECTION 2

Page 53

Release 3

State of South Dakota
Issued: 05-26-2017

Effective: 07-01-2017

2. GENERAL REGULATIONS

2.4 PAYMENT ARRANGEMENTS AND CREDIT ALLOWANCES

2.4.7 ORDERING, RATING AND BILLING OF ACCESS SERVICES WHERE MORE THAN ONE EXCHANGE TELEPHONE COMPANY IS INVOLVED

G. Examples - Switched Access provisioned by Direct Trunked Transport and Tandem-Switched Transport (Cont'd)

2. Rate elements assessed per Exchange Telephone Company

a. Company A (C)

Entrance Facility	- 100% of DS3 monthly Entrance Facility rate and 3/1 MUX
DS1 DTT	- 100% of DS1 monthly DTT rate
Tandem Switching	- MOU rate X MOU
Tandem Transmission	- Fixed rate X MOU X BP
Tandem Transmission	- Per-mile rate X number of miles X MOU X BP

b. Company B (C)

Tandem Transport	- Transport rate X MOU X BP
Local Switching	- MOU rate X MOU
Carrier Common Line	- MOU rate X MOU

**Qwest Corporation
Access Service
Tariff**

SECTION 2
Page 53.1
Release 1
Effective: 07-01-2017

State of South Dakota
Issued: 05-26-2017

2. GENERAL REGULATIONS

2.4 PAYMENT ARRANGEMENTS AND CREDIT ALLOWANCES

2.4.7 ORDERING, RATING AND BILLING OF ACCESS SERVICES WHERE MORE THAN ONE EXCHANGE TELEPHONE COMPANY IS INVOLVED

G. Examples - Switched Access provisioned by Direct Trunked Transport and Tandem-Switched Transport (Cont'd)

Feature Group D Access Service Ordered

Example 2

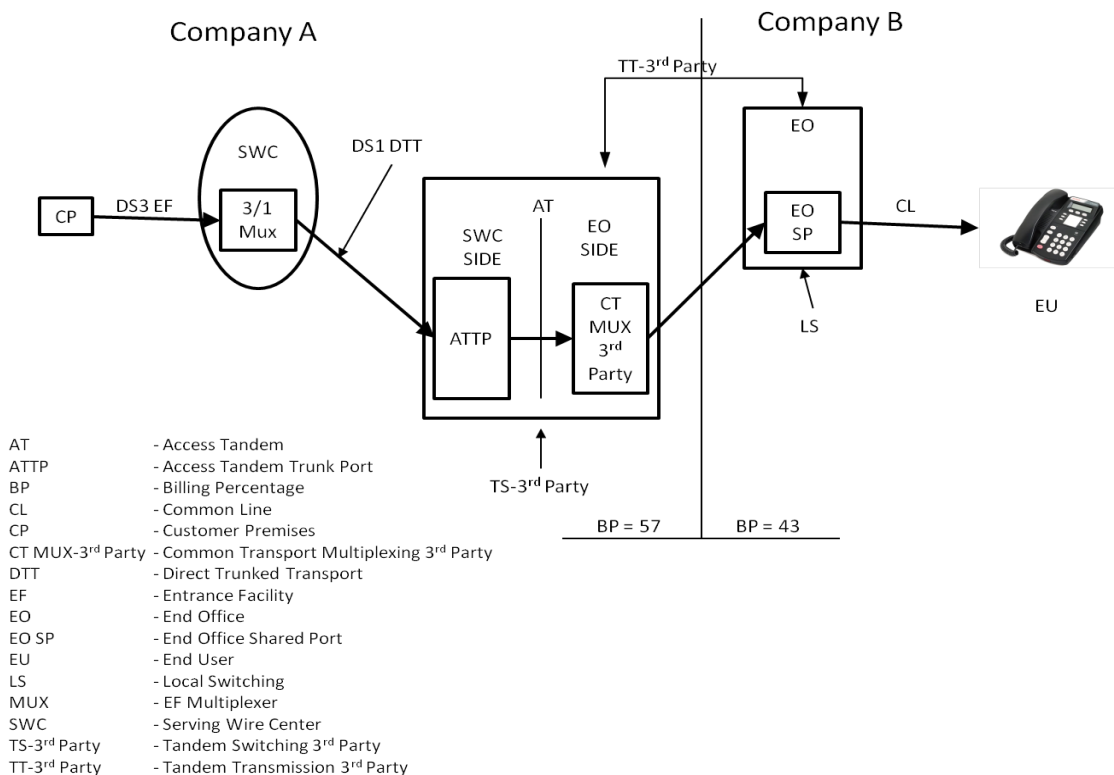

(N)

Qwest Corporation
Access Service
Tariff

SECTION 2

Page 53.2

Release 1

State of South Dakota
Issued: 05-26-2017

Effective: 07-01-2017

2. GENERAL REGULATIONS

2.4 PAYMENT ARRANGEMENTS AND CREDIT ALLOWANCES

2.4.7 ORDERING, RATING AND BILLING OF ACCESS SERVICES WHERE MORE THAN ONE EXCHANGE TELEPHONE COMPANY IS INVOLVED

G. Example - Switched Access provisioned by Direct Trunked Transport and Tandem-Switched Transport (Cont'd)

3. Example 2 Layout

- a. Terminating Feature Group D Switched Access is ordered to an end office via DTT & TST. Terminating – Tandem 3rd Party rates would appl.
- b. The premises of ordering customer, the serving wire center (SWC) of that premises, and the access tandem are in operating territory of Company A.
- c. The customer orders a DS3 Entrance Facility from the customer's premises to the SWC with a 3/1 Mux in the SWC.
- d. The customer orders a DS1 DTT to the AT.
- e. The BP for TT is 57 for Company A.
- f. Company B is not a CLOC ILEC.
- g. The end office is in the operating territory of Company B.
- h. The BP for transport is 43 for Company B.

(N)

(N)

Qwest Corporation Access Service Tariff

SECTION 2

Page 53.3

Release 1

State of South Dakota
Issued: 05-26-2017

Effective: 07-01-2017

2. GENERAL REGULATIONS

2.4 PAYMENT ARRANGEMENTS AND CREDIT ALLOWANCES

2.4.7 ORDERING, RATING AND BILLING OF ACCESS SERVICES WHERE MORE THAN ONE EXCHANGE TELEPHONE COMPANY IS INVOLVED

- G. Examples - Switched Access provisioned by Direct Trunked Transport and Tandem-Switched Transport (Cont'd)

Feature Group D Access Service Ordered

Example 3

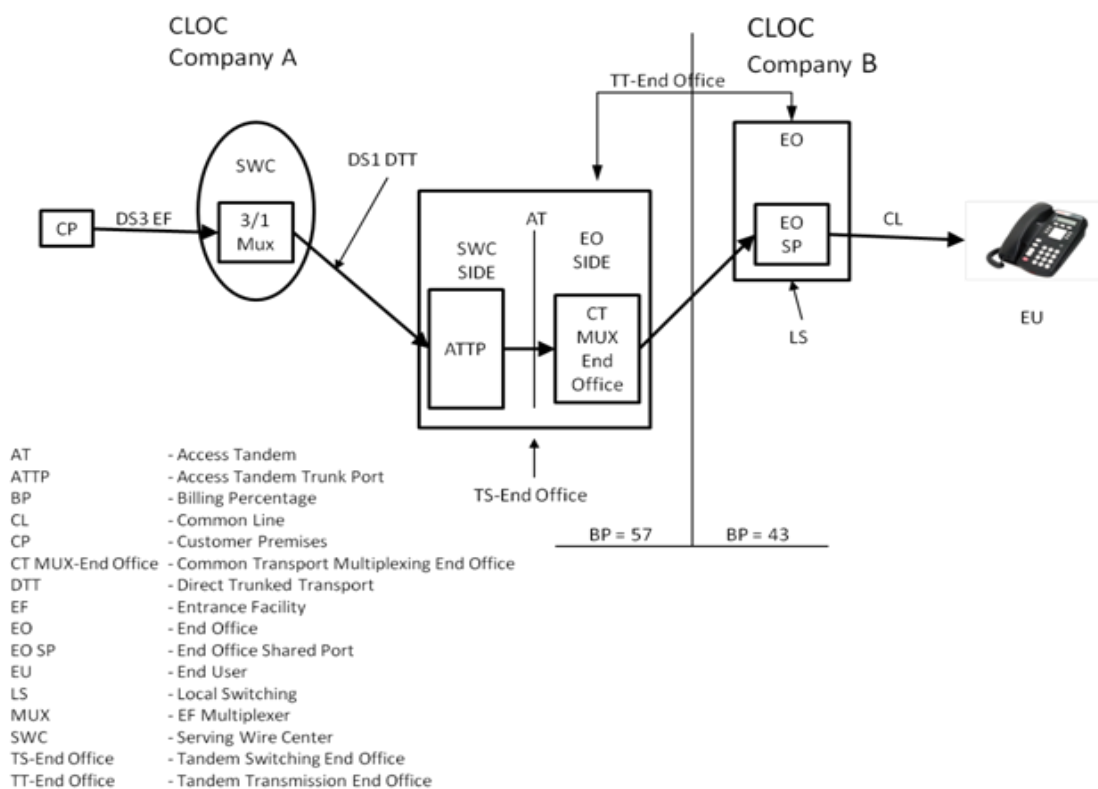

(N)

(N)

Qwest Corporation
Access Service
Tariff

SECTION 2

Page 53.4

Release 1

State of South Dakota
Issued: 05-26-2017

Effective: 07-01-2017

2. GENERAL REGULATIONS

2.4 PAYMENT ARRANGEMENTS AND CREDIT ALLOWANCES

2.4.7 ORDERING, RATING AND BILLING OF ACCESS SERVICES WHERE MORE THAN ONE EXCHANGE TELEPHONE COMPANY IS INVOLVED

G. Examples - Switched Access provisioned by Direct Trunked Transport and Tandem-Switched Transport (Cont'd)

4. Example 3 Layout

- a. Terminating Feature Group D Switched Access is ordered to an end office via DTT & TST. Terminating – Tandem End Office rates would apply
- b. The premises of ordering customer, the serving wire center (SWC) of that premises, and the access tandem are in operating territory of Company A.
- c. The customer orders a DS3 Entrance Facility from the customer's premises to the SWC with a 3/1 Mux in the SWC.
- d. The customer orders a DS1 DTT to the AT.
- e. The BP for TT is 57 for Company A.
- f. Company B is a CLOC ILEC.
- g. The end office is in the operating territory of Company B.
- h. The BP for transport is 43 for Company B.

(N)

(N)

Qwest Corporation
Access Service
Tariff

SECTION 2

Page 54

Release 3

State of South Dakota
Issued: 05-26-2017

Effective: 07-01-2017

2. GENERAL REGULATIONS

2.4 PAYMENT ARRANGEMENTS AND CREDIT ALLOWANCES (Cont'd)

2.4.8 ORDERING, RATING AND BILLING OF SWITCHED ACCESS PROVIDED IN CONJUNCTION WITH A COMMERCIAL MOBILE RADIO SERVICE PROVIDER

When Switched Access Service is ordered by a customer in conjunction with a Commercial Mobile Radio Service provider, the Company will provide its portion of the Switched Access Service based on the regulations, rates and charges contained in this Tariff, subject to the following rules.

If the Company and the Commercial Mobile Radio Service provider have agreed to jointly provide the Switched Access Service, the Meet Point Billing provisions as set forth in 2.4.7, preceding, shall determine the ordering, rating and billing for access services.

If the Company and the Commercial Mobile Radio Service provider have not agreed to jointly provide the Switched Access Service under the provisions of Meet Point Billing, the Company shall provide the Switched Access Service to the carrier subject to the following rules.

- If the Company provides the Switched Transport and provides end office local switching functions, the customer will be assessed all applicable Switched Access Service rates (i.e., Switched Transport and Local Switching). Carrier Common Line rates will not be assessed.
- If the Company provides the Switched Transport and does not provide end office local switching functions, the Company will assess all applicable Switched Access Service charges, including the Switched Transport Tandem 3rd Party charges.

(C)
(C)

The mileage to be used to determine the Switched Transport rate is calculated as set forth in 6.7.11, following.

Qwest Corporation
Access Service
Tariff

SECTION 6

Page 15

Release 4

State of South Dakota
Issued: 05-26-2017

Effective: 07-01-2017

6. SWITCHED ACCESS SERVICE

6.1 GENERAL

6.1.2 RATE CATEGORIES

A. Switched Transport

1. General Description (Cont'd)

c. Switched Transport TST Rate Category

TST provides the transmission facilities between an access tandem and end offices subtending that tandem utilizing tandem switching functions. TST is not available from or to a Company Hub. TST consists of circuits used in common by multiple customers from the access tandem to an end office. For TST, the Company will determine the type of facilities to the end office(s) based on the customer's order for service on a per-trunk basis. For example of Tandem Switched Transport see Section 2.4.7 preceding.

(C)
(C)

The TST rate category is composed of the rate elements set forth in (1) and (2), following. Rates and charges are set forth in 6.8, following.

(1) Tandem Transmission

Tandem Transmission is composed of a fixed per-MOU rate and per-mile/per-MOU rate. The fixed rate provides for the circuit equipment at the end of the interoffice transmission paths. The per-mile rate provides for the transmission facilities, including intermediate transmission circuit equipment between the end points of the interoffice circuit. For purposes of determining the per-mile rate, mileage will be measured as airline mileage using the V & H coordinates method. Mileage measurement rules are set forth in 6.7.11, following.

(2) Tandem Switching

Tandem Switching is a per-MOU rate assessed for utilizing tandem switching functions when tandem routing is requested for trunkside services. Tandem Switching is not assessed to FGA Services.

(3) Access Tandem Trunk Port

An access tandem trunk port (ATTP) is provided for each trunk terminated on the SWC side of the access tandem when the customer has requested tandem routing. The ATTP rate is assessed monthly per Feature Group trunk (excludes FGA).

Qwest Corporation
Access Service
Tariff

SECTION 6

Page 139

Release 4

State of South Dakota
 Issued: 05-26-2017

Effective: 07-01-2017

6. SWITCHED ACCESS SERVICE

6.8 RATES AND CHARGES

6.8.1 SWITCHED TRANSPORT (Cont'd)

C. Tandem-Switched Transport Usage Rates

MILEAGE BANDS	RATE PER ACCESS MINUTE	
	FIXED	PER MILE

1. Tandem Transmission

• Originating

0	-	-
Over 0 to 8	\$0.000237	\$0.000015
Over 8 to 25	0.000273	0.000018
Over 25 to 50	0.000308	0.000019
Over 50	0.000311	0.000020

• Terminating – Tandem 3rd Party

(C)

0	-	-
Over 0 to 8	0.000240	0.000030
Over 8 to 25	0.000240	0.000030
Over 25 to 50	0.000240	0.000030
Over 50	0.000240	0.000030

• Terminating – Tandem End Office

(N)

0	-	-
Over 0 to 8	0.000000	0.000000
Over 8 to 25	0.000000	0.000000
Over 25 to 50	0.000000	0.000000
Over 50	0.000000	0.000000

(N)

(M)

(M) Material moved to Page 139.1.

Qwest Corporation
Access Service
Tariff

SECTION 6
Page 139.1
Release 1
Effective: 07-01-2017

State of South Dakota
Issued: 05-26-2017

6. SWITCHED ACCESS SERVICE

6.8 RATES AND CHARGES

6.8.1 SWITCHED TRANSPORT (Cont'd)

C. Tandem-Switched Transport Usage Rates

	RATE PER ACCESS MINUTE	(M)
2. Tandem Switching Charge:		
Originating	\$0.007664	
Terminating – Tandem 3rd Party	0.002252	(C-M)
Terminating – Tandem End Office	0.000700	(N)
3. Common Transport Multiplexing:		(M)
Originating	0.000036	
Terminating – Tandem 3rd Party	0.000036	(C-M)
Terminating – Tandem End Office	0.000000	(N)
	MONTHLY	(M)
	RATE	
4. Access Tandem Trunk Port Charge, per port	\$6.00	(M)

(M) Material moved from Page 139.

Qwest Corporation
Access Service
Tariff

SECTION 6

Page 149

Release 7

State of South Dakota
Issued: 05-26-2017

Effective: 07-01-2017

6. SWITCHED ACCESS SERVICE

6.8 RATES AND CHARGES (Cont'd)

6.8.2 LOCAL SWITCHING

A. Local End Office Switching

	RATE PER ACCESS MINUTE
• LS1 - Feature Groups A and B	
Originating	\$0.008557
Terminating	0.000000 (R)
• LS2 - Feature Groups C and D	
Originating	0.008557
Terminating	0.000000 (R)
• End Office Shared Port	
Originating	0.000747
Terminating	0.000000
	MONTHLY RATE
• End Office Dedicated Trunk Port,[1] per trunk	\$3.00

[1] The End Office Dedicated Trunk Port rate was calculated based upon a 50/50 split between originating and terminating traffic using this flat-rated port. The FCC in their FCC 11-161 ICC Transformation order in section 51.907(d)(1) allowed Price Cap Carriers to use an equal split to divide the charge between originating and terminating elements. When the terminating portion of the rate is reduced and then combined with the originating portion of the rate a single flat rate is generated for billing purposes. The Originating portion of the charge is \$3.00.