

APPENDIX O
OPERATION AND MAINTENANCE PLAN

Class II
Item no.: 964106.R00
2007-06-29

Mechanical Operating and Maintenance Manual

V90 – 3.0 MW, VCRS 60 Hz

Onshore/Offshore (Mk 7)

History of this Document

Rev. no.	Date	Description of changes
00	2007-06-29	First edition

Table of Contents

1	Preface	3
2	Updating of the Manual	3
3	The Header	3
4	Contents	4

Please see Mechanical Drawings & Parts List

1 Preface

This manual applies to the wind turbine **V90 - 3.0MW, VCRS 60 Hz, Mk-7**.

It is the turbine owner's responsibility that only qualified persons operate the turbine.

Do not operate the turbine before, as a minimum, having studied the following carefully:

- ✓ 960314 Safety Regulations for Operators and Technicians
- ✓ 950173 User Guide

Do not hesitate to contact your plant manager or Vestas' Service Department if you need more detailed explanations.

Vestas Wind Systems A/S

Alsvej 21

DK-8900 Randers

Telephone: +45 9730 0000

2 Updating of the Manual

The manual will continuously be brought up to date. Corrections to each specific chapter are listed for the past year under the heading of "History of this Document".

3 The Header

The latest revision date of a specific chapter is stated in the header of the chapter. Class II indicates that the document is only handed out according to agreement with Vestas' Technology Department.

Each specific chapter has its own item number followed by a revision number (Rx).

First editions have revision number R0.

4 Contents

Item no.	Title	Chapter
960314	Safety Regulations for Operators and Technicians	1
958627	Manual Rotor Lock	2
959055	Rescue Equipment RED Pro	3
946812	Conversion Tables	4
958640	Blades	5
963233	Blade Bearing	6
961109	Pitch System	7
958638	Gearbox	8
958630	Brake System	9
950270	Composite Coupling	10
963244	Gear Oil Lubrication System	11
958534	Generator and Transformer	12
958612	Yaw Gear	13
960304	Yaw Bearing System	14
958614	Hydraulic System	15
958636	Wind Sensor and Anemometer	16
958532	Air Conditioning System	17
950263	Tubular Tower	18
958637	Surface Treatment	19
958639	Lightning Current Transfer Unit	20
962638	Rotating Contact ND-end, Generator	21
962649	Rotating Contact in D-end	22
960301	Cooling System	23
958658	Rotating Transfer	24
963560	Mechanical Drawings & Parts List	25

Supplier Drawings

Item no.	Title	Chapter
963243	Gearbox Drawings	26
943674	Parking Brake Drawings	27
958610	Yaw Gear Drawings	28
963504	Generator Drawings	29

Safety Regulations for Operators and Technicians, V90-3MW/V100-2.75MW

History of this Document

Rev. no.:	Date:	Description of change
0	2005-06-23	First edition
1	2005-09-19	947554 replaced by 959055; Chap. 9: "However, the capacitors in the converter and AGO2 section might be energized." inserted Chapter 10 Converter and AGO2 Sections Figure numbers updated
2	2006-01-17	Reference to 947554 added again page 12
3	2006-03-03	Chapter 18.1.1. New wind speed limit 23m/s
4	2006-05-08	Language revision. Inserted: section 14.2 Access to roof, text and picture.
5	2006-09-11	Reference to V100 added Section 19 updated with new pictures and new text.

Contents	Page
1. Introduction	3
2. Stay and Traffic by the Turbine.....	3
3. Address and Phone Number of the Turbine	3
4. Controller and Operating Panel	4
5. Emergency Stop Buttons	4
5.1 Trip F60	8
5.2 Lift (Optional)	8
5.3 Internal Crane	8
6. Practical Advice at Inspection.....	8
7. Influence by Lubricants.....	8
8. High Voltage Installations	8
9. Grid Drop-Out	9
10. Converter and AGO2 Sections	9
11. Turbine Standstill	9
12. Overspeed Guard	10
13. Inspection of the Turbine	10
14. Safety Equipment	12
14.1 ResQ Emergency Rescue Equipment.....	13
14.2 Access to Roof	14
15. Hooking Points and Safety Chains	15
16. Precautions in Case of Fire	17
17. Directions for Use of Rotor Lock.....	17
18. Operating the Rotor Locking System.....	19
18.2 Operating the Manual Rotor Locking System with Bolts	21
19. Operating the Internal Crane	25

1. Introduction

A turbine connected to the grid implies certain elements of danger if it is handled without exercising proper caution.

For safety reasons, at least two persons have to be present during a work procedure.

The work must be properly carried out in accordance with this manual and other related manuals. This implies, among other things that personnel must be instructed in and familiar with relevant parts of this manual.

Furthermore, personnel must be familiar with the contents of the “Substances and Materials” regulations.

Caution must especially be exerted in situations where measurement and work is done in junction boxes that can be connected to power.

Consequently the following safety regulations must be observed.

2. Stay and Traffic by the Turbine

Do not stay within a radius of 400m (1300ft) from the turbine unless it is necessary. If you have to inspect an operating turbine from the ground, do not stay under the rotor plane but observe the rotor from the front.

Make sure that children do not stay by or play nearby the turbine. If necessary, fence the foundation. The access door to the turbine must be locked in order to prevent unauthorised persons from stopping or damaging the turbine due to mal-operation of the controller.

3. Address and Phone Number of the Turbine

Note the address and the access road of the turbine in case an emergency situation should arise. The address of the turbine can often be found in the service reports in the ring binders next to the ground controller. Find the phone number of the local life-saving service.

4. Controller and Operating Panel

Only authorised or instructed persons are allowed to open the doors of the controller cabinet.

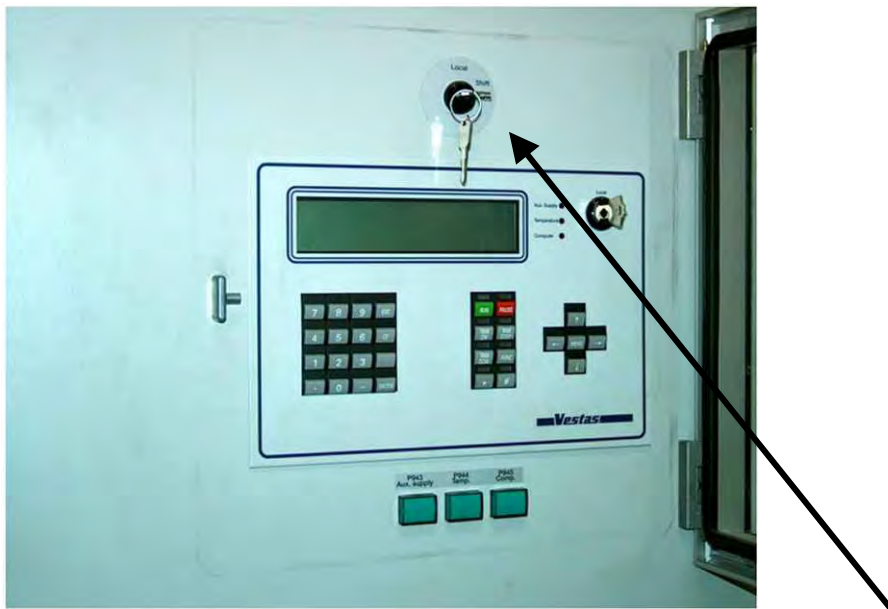

Picture 1

Before inspecting or working on the turbine, the remote control **MUST** be deactivated. Use the breaker-key and set it in position “local”. Remember to activate the remote control when the inspection or the work has been completed.

5. Emergency Stop Buttons

For safety reasons please note the location of the 4 emergency stop buttons. The buttons are located (Figure 1 Locations of emergency stop buttons and trip F60 in nacelle) at:

- Ground controller (at the bottom of the turbine).
- Gearbox (pos. 1).
- Yaw ring (pos. 2).
- Nose cone (pos. 3, only local stopping function)
- Nacelle controller (pos. 4).
- Trip F60 (pos. 5).

The emergency stop buttons are red with a yellow background. An emergency stop is activated by pressing one of the red buttons. When an emergency stop is activated, the controller switches to “EMERGENCY STOP” mode meaning that no power will be supplied to the contactor solenoids, the blades will pitch (full feathering), the brake will be applied and the turbine will stop. The yaw system, the hydraulic pump, the gear oil pump and the nacelle ventilator will also stop. Consequently, all moving parts will be brought to a standstill.

However, the power supply to the light, the nacelle, the hub and the ground controllers will still be on. The stop button in pos. 3 is not an emergency stop button but a local stopping function.

Remember: The hydraulic system is still under pressure. Due to the accumulators, up to 6 litres of hot oil will pour out, if the hydraulic system is intervened.

Please note: When the emergency stop buttons are activated, the brake is activated.

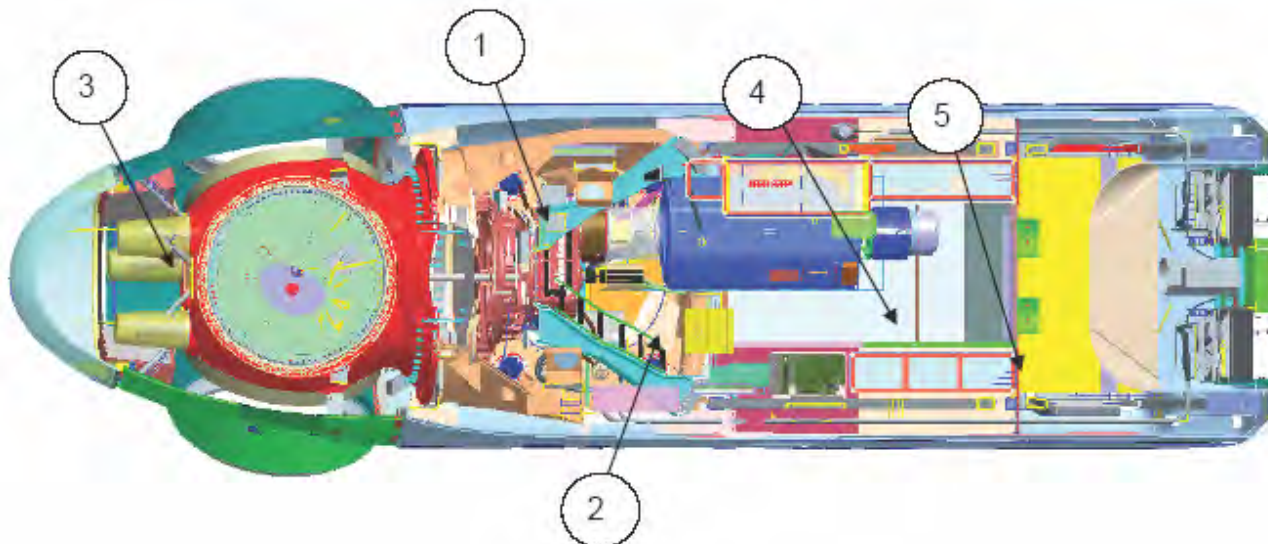
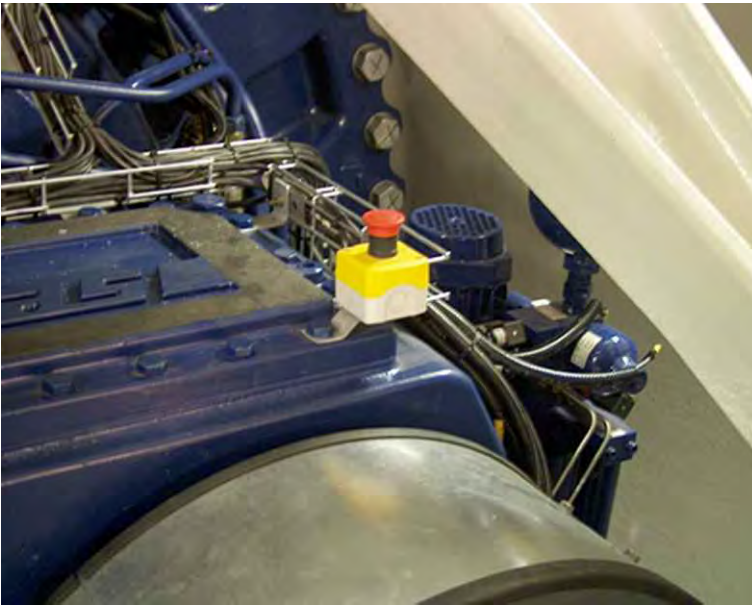

Figure 1 Locations of emergency stop buttons and trip F60 in nacelle



Picture 2 Yaw ring emergency stop button (pos. 2, Figure 1)



Picture 3 Gearbox emergency stop button (pos. 1, Figure 1)



Picture 4 Emergency stop button at nacelle controller (pos. 4, Figure 1)



Picture 5 Emergency stop button in hub (pos. 3, Figure 1)



Picture 6 The trip F60 button (pos. 5, Figure 1)

5.1 Trip F60

Trip F60 is situated on the nacelle controller (pos. 4). Trip F60 disconnects the high voltage supply for the turbine. When disconnected, only the control system in the turbine is supplied from the UPS for approx. 6 hours. Usually, the local power station must take part when the turbine is connected to the grid.

5.2 Lift (Optional)

If a lift is installed, it has several emergency stop buttons.

Note: These buttons only stop the lift; emergency stop buttons for turbine do not apply to the lift.

5.3 Internal Crane

The crane is equipped with an emergency stop button. This only applies to the crane and otherwise the emergency stop buttons in the turbine do not apply to the crane.

6. Practical Advice at Inspection

When inspecting the machinery, always look very closely for oil spills and loose bolts. Dirt must be wiped off, otherwise it can be difficult to determine whether there is a significant leak.

Loose bolts in the structure mean danger. They must be tightened immediately. If it is a matter of several bolts or repetitions, please contact Vestas Wind Systems A/S service department.

7. Influence by Lubricants



The lubricants used in the turbine can be aggressive. Lubricants must not get in contact with skin or clothes.

At inspection of a gearbox if removing a cap while the oil is still hot, be careful not to breathe in the hot oil vapours.

8. High Voltage Installations

As a basic rule it is not allowed to dismount cover or open locked doors to the high voltage installations.

An operator/service technician is only allowed to move around behind the covering when the high voltage is disconnected, locked and visibly earthed. The work must be carried out and approved by authorised personnel only (power station or selected coupling leader). One of these persons must give permission to access the HV installation.

Work done on high voltage installations must be carried out in accordance with national regulations and related Vestas Wind Systems A/S manuals.

9. Grid Drop-Out

A grid drop-out causes an EMERGENCY STOP. The blades pitch out of the wind (full feathering); the yaw system, the hydraulic pump and the nacelle ventilator stop. Consequently, all moving parts will be brought to a standstill except for emergency lubrication system for the gearbox. The power supply for the light and the nacelle, hub and ground controllers is partly off. However, the capacitors in the converter and AGO2 section might be energized.

10. Converter and AGO2 Sections

WARNING:

If working on the converter section or AGO2 section, note that the capacitors inside can be charged to 800 V and those in the filters can be charged to 690 V. The capacitors are discharged to below 50 V in 5 minutes after disconnection from the grid. Switch Q7 and Q8 must be turned off.

Before opening the cabinet, check the DC-link-voltage in picture 17.

Before working on the converter/AGO2, check the DC-link-voltage with a Fluke multimeter.

11. Turbine Standstill

After a period of maximum 14 days without grid connection, necessary equipment for humidity- and temperature control must be installed in the turbine in order to fulfil the following requirements:

- For 90 % of the shutdown period, the relative humidity (RH) must not exceed 45 %.
- The RH must be between 45% and 60% for max. 10% of the shutdown period only.
- Within a period of 12 hours, the temperature in the turbine must not drop more than 10° C.
- The temperature and humidity must be logged.

During a period without grid connection, the following inspections must be carried out on a monthly basis:

- Check the functionality of the equipment as regards humidity and temperature.
- Check the RH and temperature logging in accordance with the requirements mentioned above.
- Check the emergency lubrication.
- Recharge emergency lubrication batteries (only every 3 months).
- Check the blade locking system.
- Check that the brake is released and without pressure.

12. Overspeed Guard

If the turbine rotation exceeds its limit, the overspeed guard (VOG) is activated, and the turbine will go into EMERGENCY STOP mode. The state of failure cannot be reset until the VOG has been de-energized.

13. Inspection of the Turbine

At inspection of the turbine, the following procedure must be followed.

When inspecting the turbine there must always be at least two persons present.

Full feathering of the blades is done by pressing <PAUSE>. When the rotor comes to a standstill or rotates slowly, activate the <Emergency stop button> to stop the turbine.

It is now possible to climb the turbine but remember as a minimum to wear:

- Safety footwear suitable for climbing towers.
- H-belt with fall protection device fastened directly to the H-belts D-ring on your chest.
- Safety helmet.

Always make sure that there is nobody above you in the turbine when you start the ascent.

If you bring tools, lubricants etc. with you, keep these in a rucksack or a bag which is attached to the safety belt.

During the ascent the fall protection and the supporting strap **MUST** be mounted. Do not mount the fall protection hook on the aluminium ladder rungs or on the fittings for the ladder, as they might brake in case of falling. Instead the swivel eye plate (yellow) must be used.

Close the trap doors of the landings when passing them.

Please notice the location of the emergency stop buttons and Trip F60 in the nacelle.

When working on the electrical part of the controller, the controller must be disconnected by the circuit breaker (marked Q7, Q26 and Q27) in the board arrangement and locked by means of a padlock.

Only authorised personnel must have access to the key/keys.

When working on the terminal of the generator, inspecting the generator cables or the controlling as such, the generator must be disconnected by the circuit breaker (Q8 and Q23) in the board arrangement and locked by means of a padlock. Only authorised personnel must have access to the key/keys.

When working on the yaw system, the yaw motors must be disconnected in the control panel at the contactors F35.1 and F35.2.

Always make sure that there is nobody below the turbine while you are working in the nacelle. Even a small screw is highly dangerous when falling from a height of 60m or more.

Unauthorised persons must under no circumstances move the covering plates which cover rotating or electrical parts, especially the high voltage installation. Be cautious that safety straps are not caught on any rotating shafts during stay in the nacelle while the turbine is in operation.

Before entering the hub or working on rotating parts in the nacelle, make sure that the rotor is locked and that the blades are fully feathered. See section “Operating the Rotor Locking System” on how to activate the rotor locking system.

Before descent, close the nacelle skylights and the service hatch. Make sure that you have gathered all tools and remember that the red emergency stop buttons must be off.

If the blades are iced up, it is highly dangerous to stay below or close to the rotor. If the turbine is to be restarted with iced up blades, the operator must be very careful and make sure that no persons are nearby because of the risk of falling pieces of ice.

Do not stay in the nacelle while the turbine is in operation, unless if checking for gear and generator noise.

Any oil or grease spills must be cleaned up because of the risk of slipping.

Make sure that the covering and the locking of the high voltage installations are undamaged.

Make sure that the high voltage cable between the high voltage installations in the nacelle and the bottom are undamaged and do not have any visible mechanical damages, such as having been squeezed/cut by cable binders, mechanical parts etc.

When working in the nacelle, spinner or roof, please pay attention to safety hooking points. See figure 3.

When working on the roof of the nacelle, secure a safety line on the roof rail. See Picture 11 Hooking points on the roof.

Special caution must be taken when climbing lattice towers when it is wet or icy. Moreover special cautions must be taken when climbing on the outside of the lattice tower, since the back of the blade is close to the lattice tower when the blade is turning around its longitudinal axis. This happens if anyone pushes <PAUSE> or <EMERGENCY STOP> and also at an unintended EMERGENCY STOP.

14. Safety Equipment

See Figure 2 Safety Equipment

1. Safety helmet.
2. H-belt (delivered by Vestas).
3. Lanyards: one line with a fall damper device, one line with a shortening device (delivered by Vestas).
4. Fall protection device (delivered by Vestas).
5. Rubber-soled footwear properly tightened.

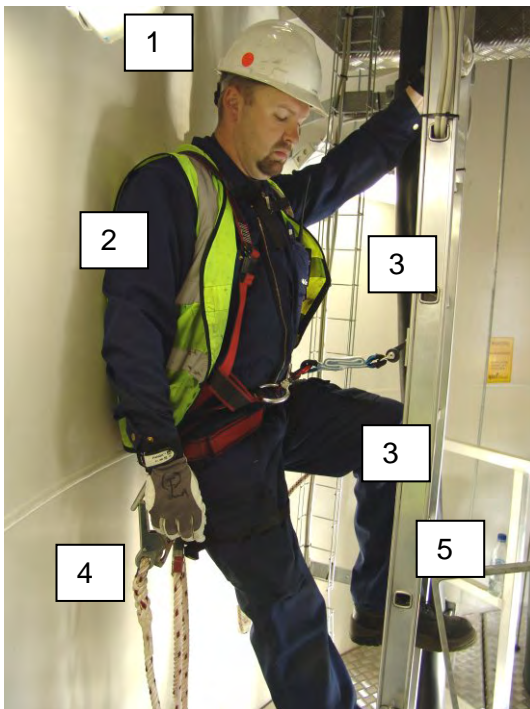

Figure 2 Safety Equipment

When climbing the tower, fasten the fall protection device directly to the H-belt's D-ring. Only one person is allowed on each ladder section at a time.

If a service lift is installed in the turbine, bring along the safety equipment in it.

14.1 ResQ Emergency Rescue Equipment

In case the escape route via the tower should be cut off by fire or other unforeseen events, a rescue and descent device is located in the nacelle behind the main controller section in an aluminium box. Please see user manual for rescue equipment, item number 959055 (VCS, 50 Hz turbines) or 947554 (VCRS, 60 Hz turbines).

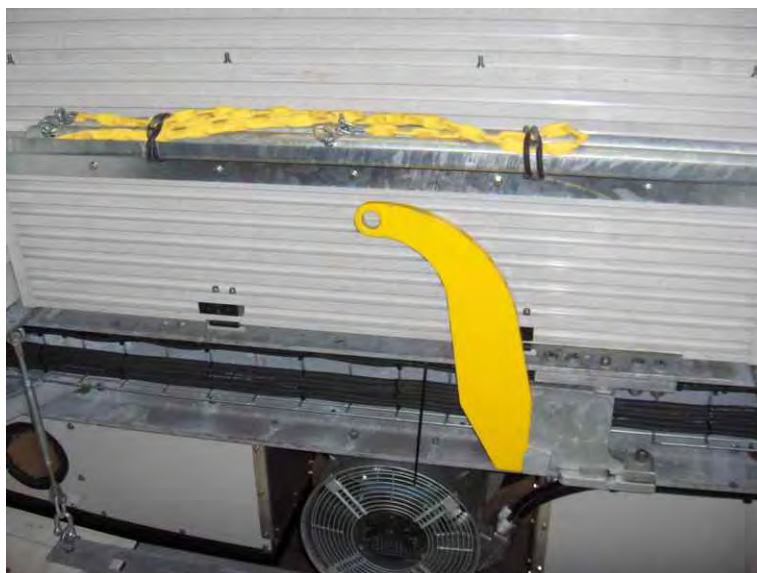

Picture 7 Fixing Point for ResQ descent device

- Fixing point for ResQ descent device.
- Open the left service hatch.
- Lift the arm above the opening.
- Fasten the ResQ descent device to the arm.
- Ready for lowering, SWL 2000kg.

14.2 Access to Roof

Place the ladder on machine foundation at the rear of the nacelle to gain access to nacelle roof as shown in the picture below.



Picture 8 Ladder to roof

15. Hooking Points and Safety Chains

A number of hooking points is installed at different locations in the nacelle. A hooking point is shown in Picture 9 Hooking point.

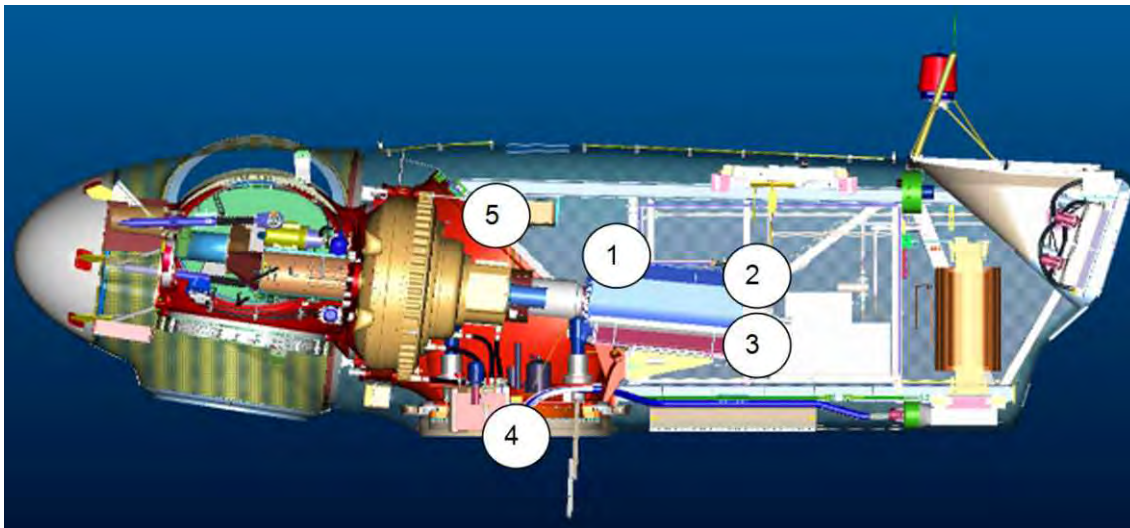

Figure 3 Hooking points in the nacelle and position of safety chains



Picture 9 Hooking point



Picture 10 Safety chains must be mounted when the bottom hatch is open (Figure 3)



Picture 11 Hooking points on the roof

16. Precautions in Case of Fire

At any type of fire in or near a turbine, the power to the turbine must always be disconnected at the main high voltage circuit breaker. To disconnect supply, switch off by pushing the red button (marked TRIP F60) on the nacelle controller in the nacelle. In the tower bottom the power supply is switched off by pushing the red button situated on the breaker in the high voltage section. If it is impossible to get to the main circuit breaker, contact the power station for a disconnection of the grid.

In case of a fire during an uncontrolled operation, do under no circumstances approach the turbine. Evacuate and rope off the turbine in a radius of minimum 400m (1300ft). In case of a fire in a non-operating turbine, the fire can be put out by means of a powder extinguisher.



Use of a CO2 extinguisher in a closed room can result in lack of oxygen.

17. Directions for Use of Rotor Lock

To avoid accidents and near-accidents, which can be prevented via mechanical locking of the rotor, the following guidelines must be followed:

IN GENERAL:

Besides following the requirements listed in this document, it is important also to use ones common sense and assess the specific situations.

When the wind speed exceeds the values of the mechanical design of the locking system, it is not allowed to work in a turbine as listed below.

A technical solution must be prepared before starting work on a turbine that cannot be locked mechanically.

The work listed below must not be carried out before the turbine has been mechanically locked.

Mechanical rotor locking must be used in connection with:

1. Hub and blades:
 - a. stay in hub and nose cone
 - b. stay on/near the blade is not allowed unless both the rotor and the blade has been locked
2. Work on gearbox and gear oil system if this involves:
 - a. disassembly and adjustment of mechanical parts
 - b. tensioning
 - c. activation of shrink disc
 - d. internal inspection – unless it is a visual inspection
3. Work on coupling and braking system if this involves:
 - a. disassembly and adjustment of mechanical parts

- b. tensioning
 - c. inspection of coupling
 - d. lubrication
4. Work on generator if this involves:
- a. disassembly and adjustment of mechanical parts
 - b. tensioning
 - c. work on slip ring systems/units
5. Work on yaw system
In addition to rotor locking, the turbine must be secured against unintentional yawing, if this involves:
- a. disassembly of mechanical parts
 - b. yaw brakes cannot be activated
6. Work on electricity in the nacelle, if this involves:
- a. that the turbine controller is switched off and work at rotating parts of the drive train has to be carried out.
7. Work on hydraulics for pitch as well as brake system, if this involves
- a. disassembly of mechanical parts
 - b. that the pumps are out of operation
8. Work on the turbine's exterior
In addition to rotor locking, the turbine must be secured against yawing, if this involves:
- a. use of crane
 - b. use of front lift
 - c. use of other lifts or scaffold systems
9. Replacement of components, if this involves:
- a. replacement of components, sensors, etc. close to unshielded rotating parts of the drive train.

18. Operating the Rotor Locking System

The rotor must not be locked unless it is necessary, however always when servicing the hub and it must be unlocked as soon as possible after the service operation, which caused the locking.

If the rotor has to be locked for more than 48 hours, it must be bolted to the main foundation, following the procedure description in section 18.2.

18.1.1 Operating the hydraulic rotor locking system for normal service

The rotor locking system must not be set or used at wind speeds exceeding 23 m/s.

The rotor locking system must not be used while the rotor is rotating.

Pitching of blades is not allowed while the rotor is locked, except at wind speeds below 15 m/s. In this case only one blade may be pitched at a time.

The rotor locking system is located at the upper right hand side of the main gear, see Picture 12 Rotor locking system.

1. Set the turbine to PAUSE mode and select test picture 11.7 (Manual Pitch and Brake), where the brake can be activated.
2. Align the locking system position holes in the hub with the locking system mandrels by "manoeuvring" the brake (press [*]) until the V-notch marking (pos. 1) on the hub is aligned with pointer on machine foundation (see pos. 2). See Picture 13.
3. At the correct position set the handle in "+" position and pump the locking system mandrels out. Observe at the right side during the pumping! See Figure 4.
4. The locking takes place with the hydraulic hand pump located above the main gear on right hand side. The locked position of the handle is 45°. When locking set the handle in "+" position (the handle perpendicular to the gearbox centre shaft). When unlocking set the handle in "-" position and pump in the locking system mandrels.
5. When the mandrels are fully out or in, set the handle in "lock" position, see Figure 4. Verify the fully in or out position by looking at picture 11.7.B at the operator panel.

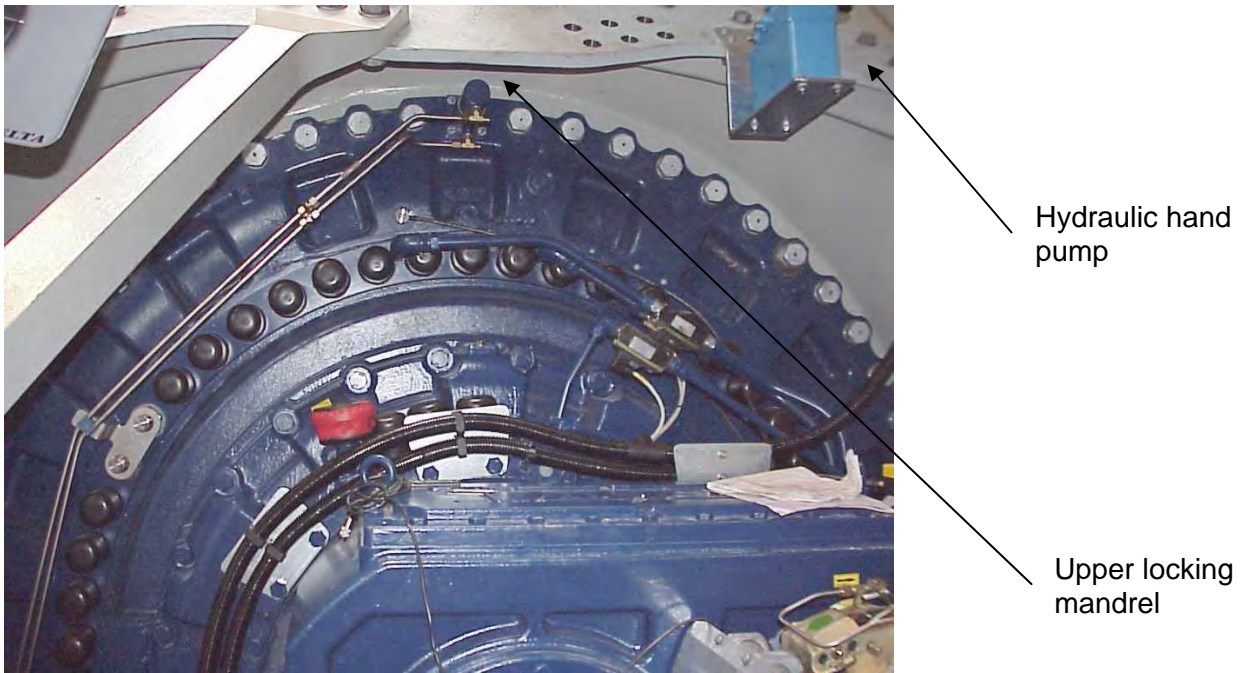

Picture 12 Rotor locking system



Picture 13 Alignment markings seen from machine foundation side

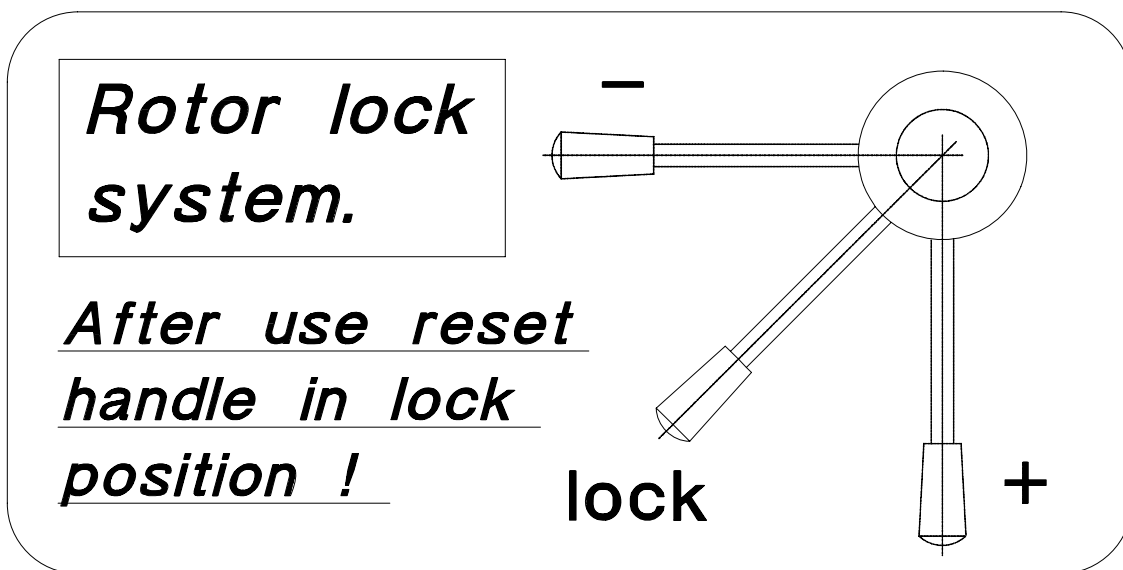

Figure 4 Handle positions

18.2 Operating the Manual Rotor Locking System with Bolts

The manual rotor locking system is used in case of servicing:

- Gearbox repairs
- Gearbox replacements
- Transport of nacelle
- Turbine standstill for long period of time: > 48 hours

The manual rotor lock must be used as an alternative to the hydraulic rotor lock

The following components must be used when operating the manual rotor lock.

Item number	Description	Quantity
950461	Centering mandrels	3
782137	M42 special nut	16
782138	Washer	16
782139	M42 special bolt	16
782142	Shim for rotor lock	16
782141	Hex.soc.h.scr.M16x60 yellow	16x8 = 128

Prior to mounting the manual rotor lock:

- Set the turbine in PAUSE mode and activate the <emergency stop button> to activate the disc brake.

18.2.1 Mounting the manual rotor lock

1. Turn the hub until the highest point points up and one of the blade bearings points downwards.
2. Lock the rotor with the hydraulic rotor lock or mount the three centering mandrels using 3 x 2 M20x40 from in front of the hub flange and into the locking holes of the main foundation.
3. Place 16 x M42 bolts (782139) 5 on each side and 6 in the top.
4. Insert 16 shims (782142) so the bolt is placed in the slot and the shims. Use a small hammer for mounting to ensure there is no space between the shim and the hub/main foundation.
5. Screw on the special nut, with washer underneath so it hits the hub flange.
6. Tighten the yellow M16 special bolts (782141) following this procedure:
Tighten the 8 M16 bolts to 70Nm. Then tighten the 8 M16 bolts to 140Nm in a circular way and proceed with this operation with the first 3 bolts again, so you at the end have tightened 11 bolts to 140Nm.
(see figure on the following page)

NOTE

Do not at any time remove the centering mandrels when the M 16 bolts are not tightened.

Tightening force sequence, the full sequence has to be used.

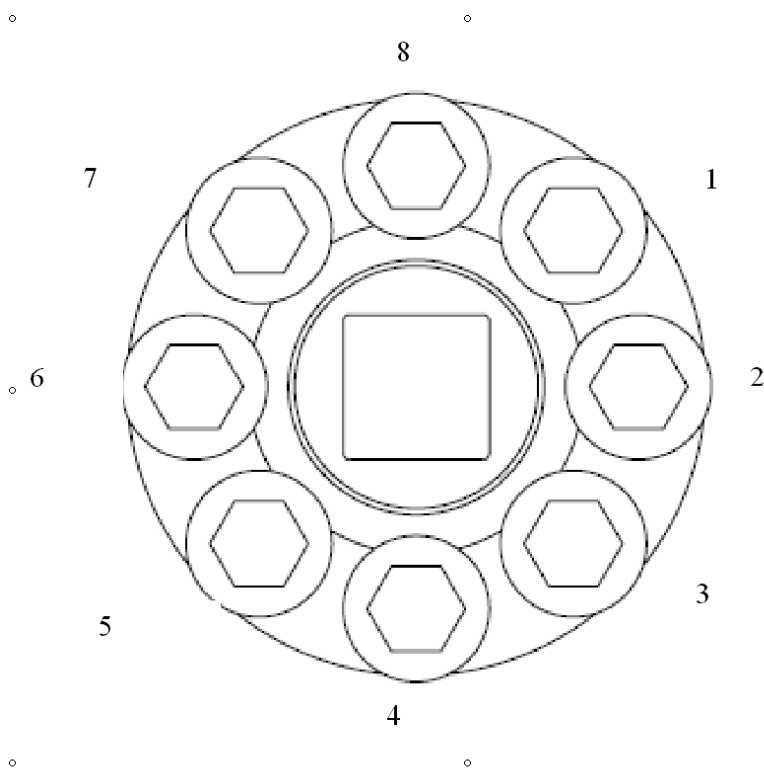

Bolt nr.	Torque Nm
1	70
2	70
3	70
4	70
5	70
6	70
7	70
8	70
1	140
2	140
3	140
4	140
5	140
6	140
7	140
8	140
1	140
2	140
3	140

Figure 5

18.2.2 Dismantling the manual rotor lock after service work

1. Loosen all the M16 special bolts.
2. Loosen and remove all M42 special nuts.
3. Remove all the M42 special pin bolts
4. Remove the centering mandrels or pull back the hydraulic rotor lock.

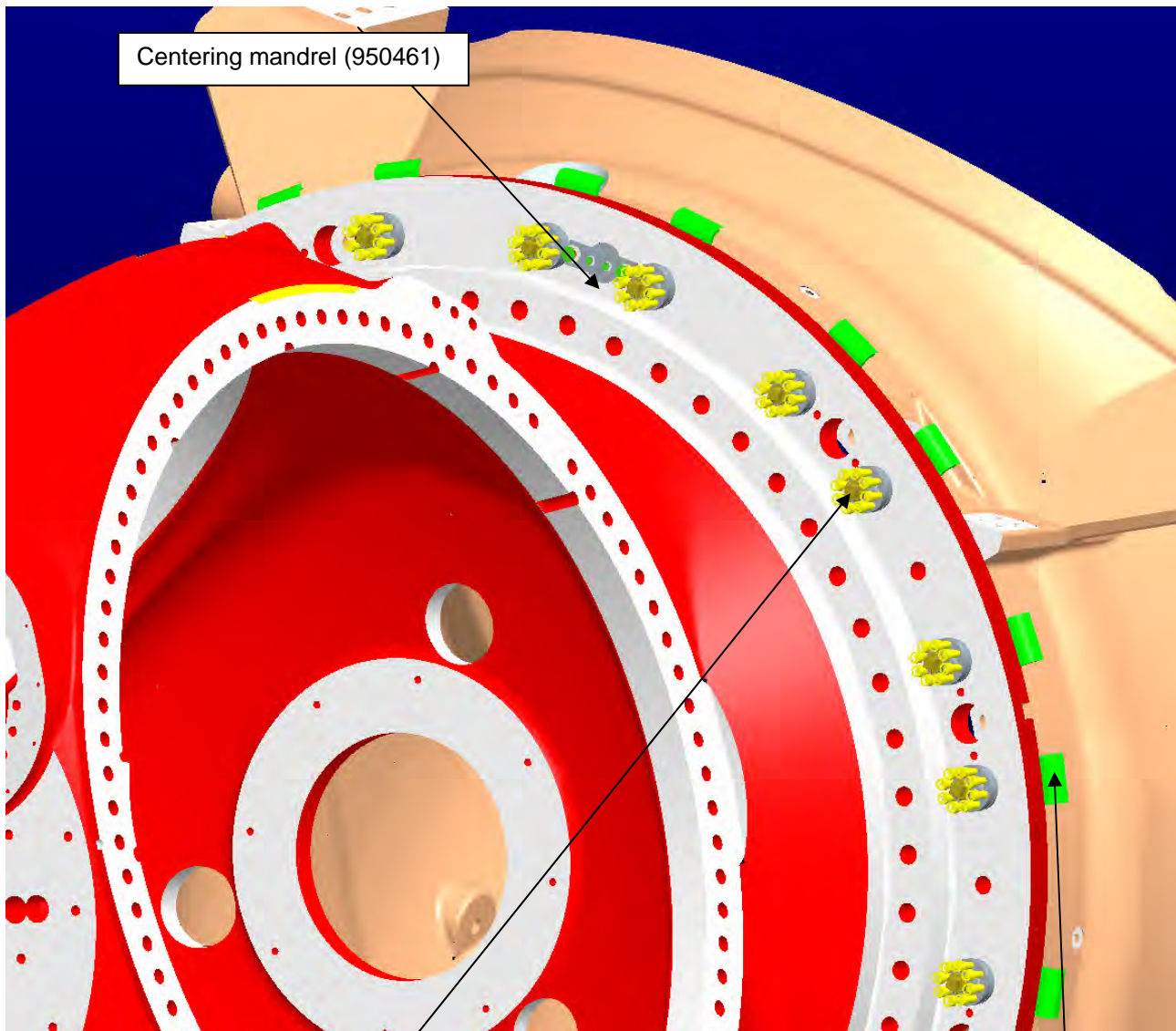

Figure 6

Bolt M42x200	(782139)
Washer	(782138)
M 42 nut	(782137)
Spec. bolt M16	(782141)

Shim (782142)

All these components are shown in an additional document 958627.

19. Operating the Internal Crane

Limitations on use:

- Lift or landing to floating vessels is not permitted for any crane constellation.
- Lift or lowering of personnel is not permitted for any crane constellation.
- Do not use any of the crane constellations for external operation above wind speed 15 m/sec 10 min.
- Do not operate the crane without correct authorization.

After 50 lifts with 12000 kg load the crane must be recertified:

- Inspect all welding on both trolleys for cracks. Repair or replace damaged items.
- Inspect all welding on lattice construction for cracks. In case of cracks Vestas Technology must be contacted.
- Replace all bolts, nuts and washers on bridge and trolley.
- Check rollers for free rotation, replace if malfunction.
- Perform overload test.

Attach chain to prevent accidental access to hazardous area.

Open the service hatch and secure it to transformer partition wall.

Keep the service hatch closed after hoisting operation is completed.

The internal crane and the traverse must be fastened in parked position when turbine in operation.



Figure 7 Attach chain



Figure 8 Service Hatch

Release the chain from the chain box.



Figure 9 The chain box

The crane can be moved longitudinally by a winch mounted on the machine foundation.



Figure 10 The Crane Winch placed on foundation.

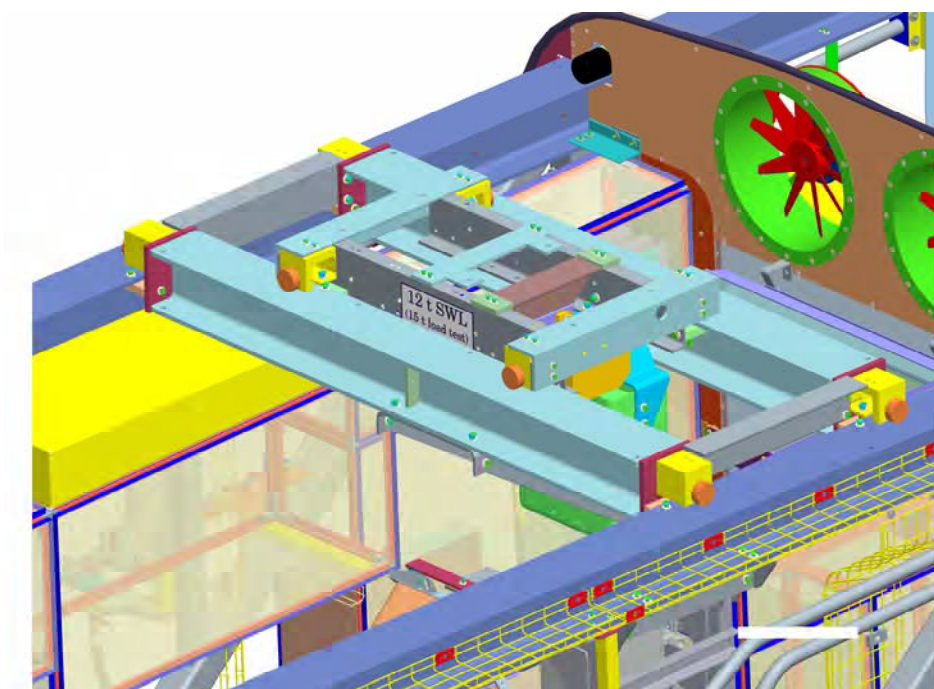

Figure 11 The crane in parked position

General crane functions:

The internal nacelle overhead traverse trolley support 4 lifting functions, each with specific manual.

- Normal service operation. Max. Work load is 800 kg.

Prior to lowering the trolley must be locked in sideways direction by tightening lock screws $\frac{1}{4}$ extra turn after contact and in longitudinally direction locked by keeping the steel wire tensioned and tightening lock screw for longitudinally direction by tightening lock screws $\frac{1}{4}$ extra turn after contact .

Warning:

Visual inspect:

- The bridge and trolley for corrosion, wear, defect bolts and connections before using the crane.
- Winch for oil/grease leaks and corrosion.

The crane must not be used before defects are repaired.

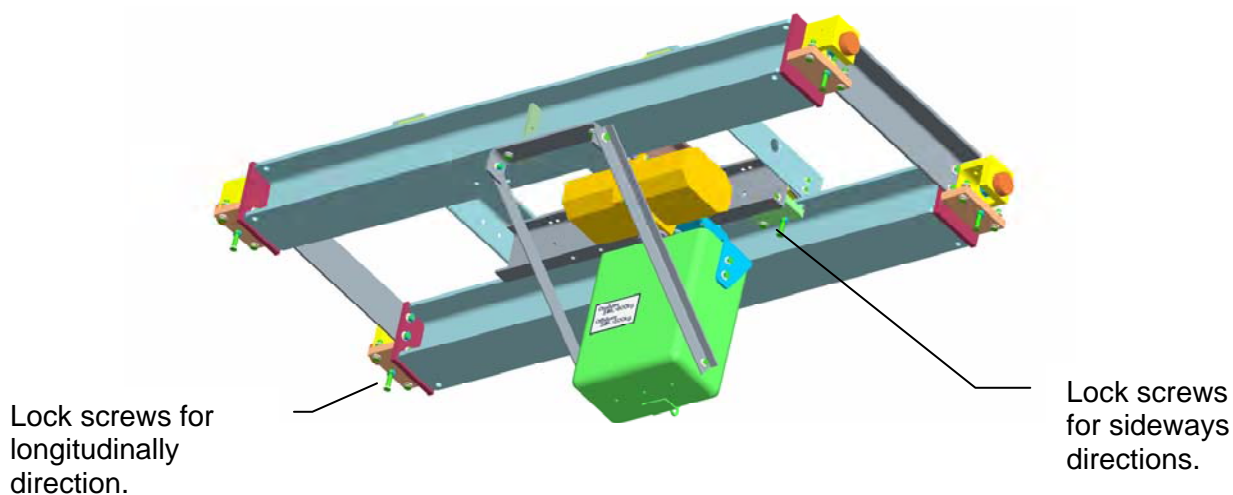
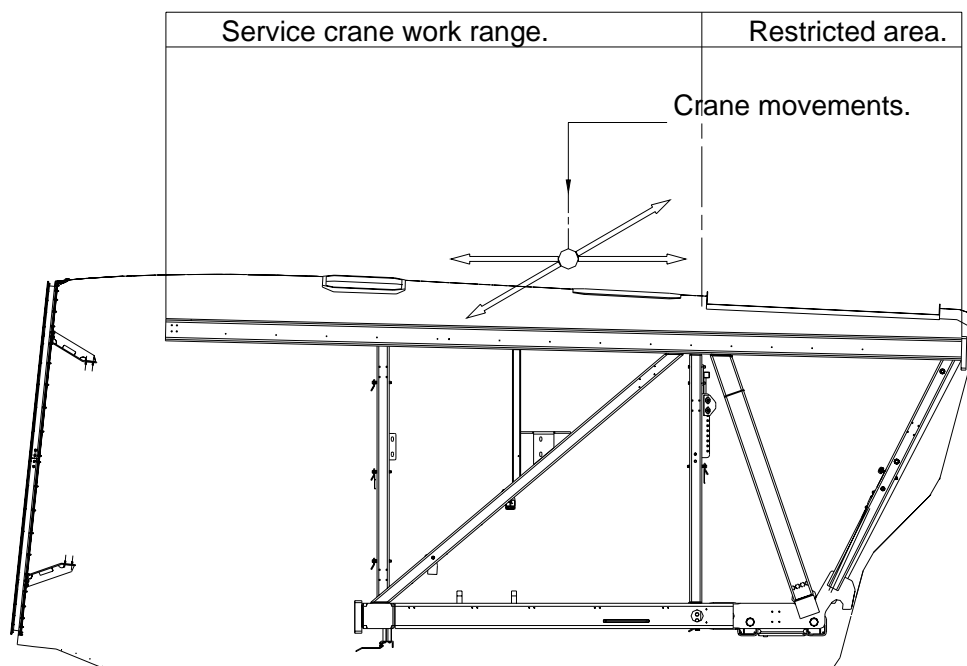

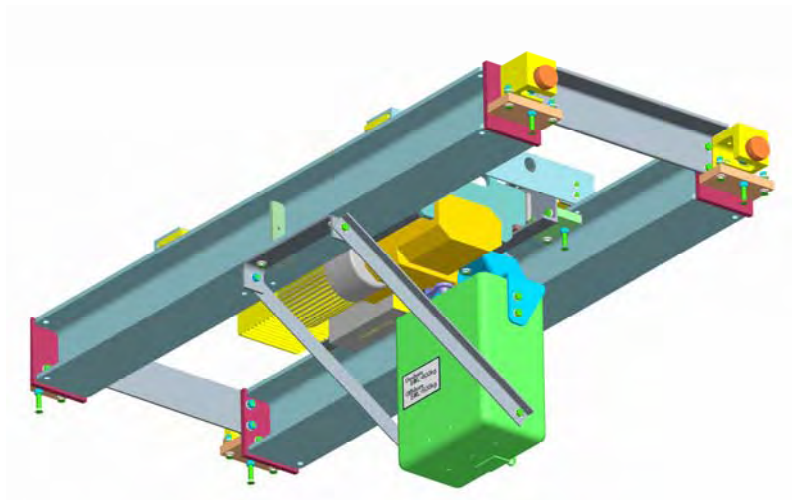

- Lifting transformer. Max. work load is 12000 kg.
This operation is only to be done by authorized personnel.

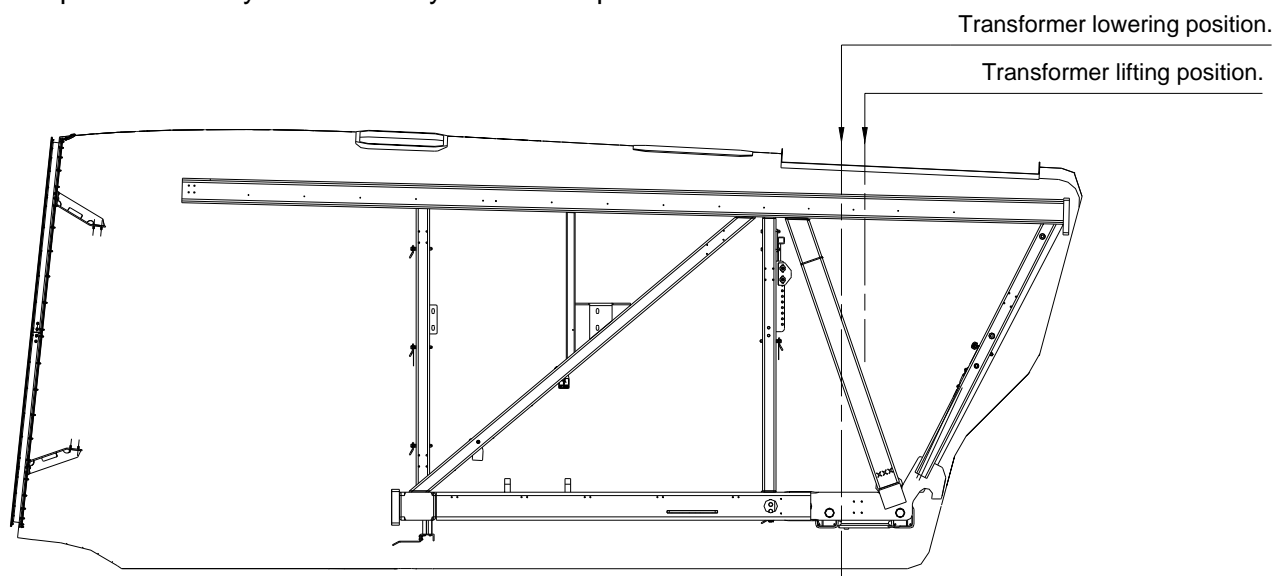

- Lifting generator. Max. Work load is 12000 kg.
This operation is only to be done by authorized personnel.

Generator lowering.

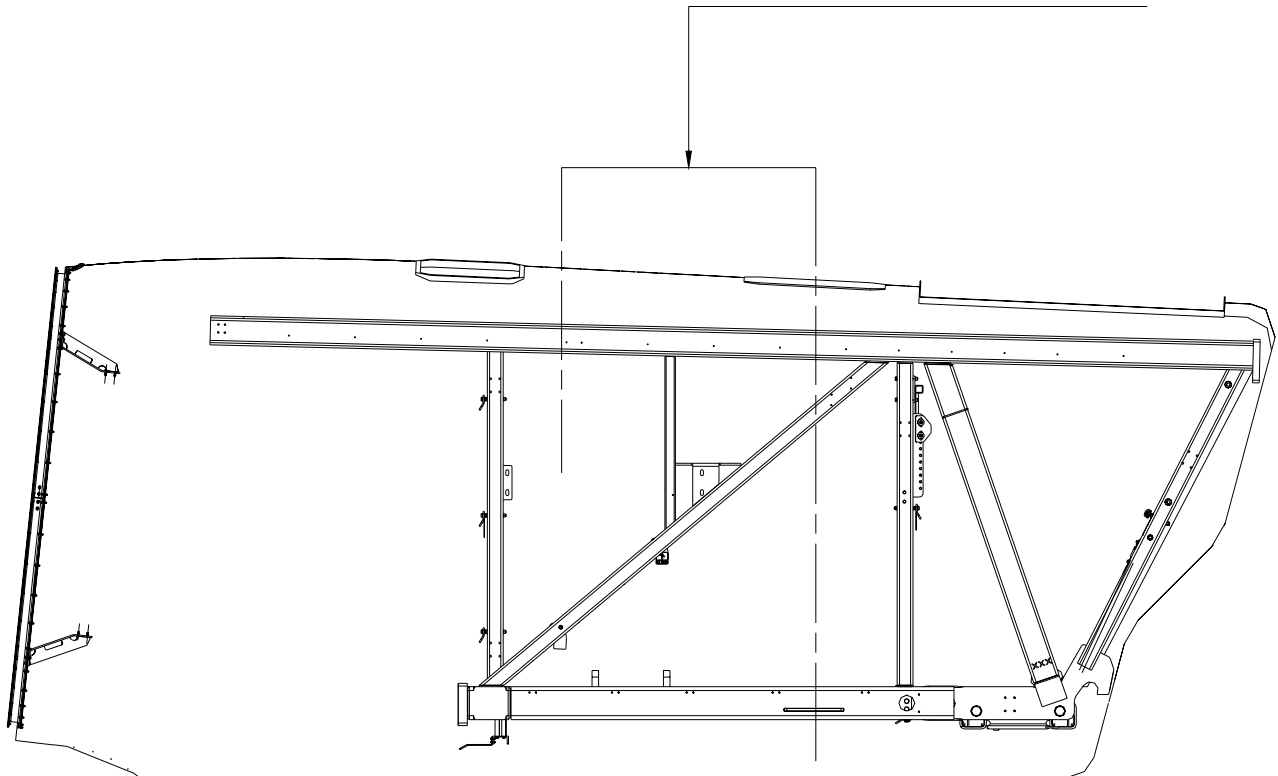

Internal crane for lifting components in the hub:

This operation is only to be done by authorized personnel.

Hub components position.

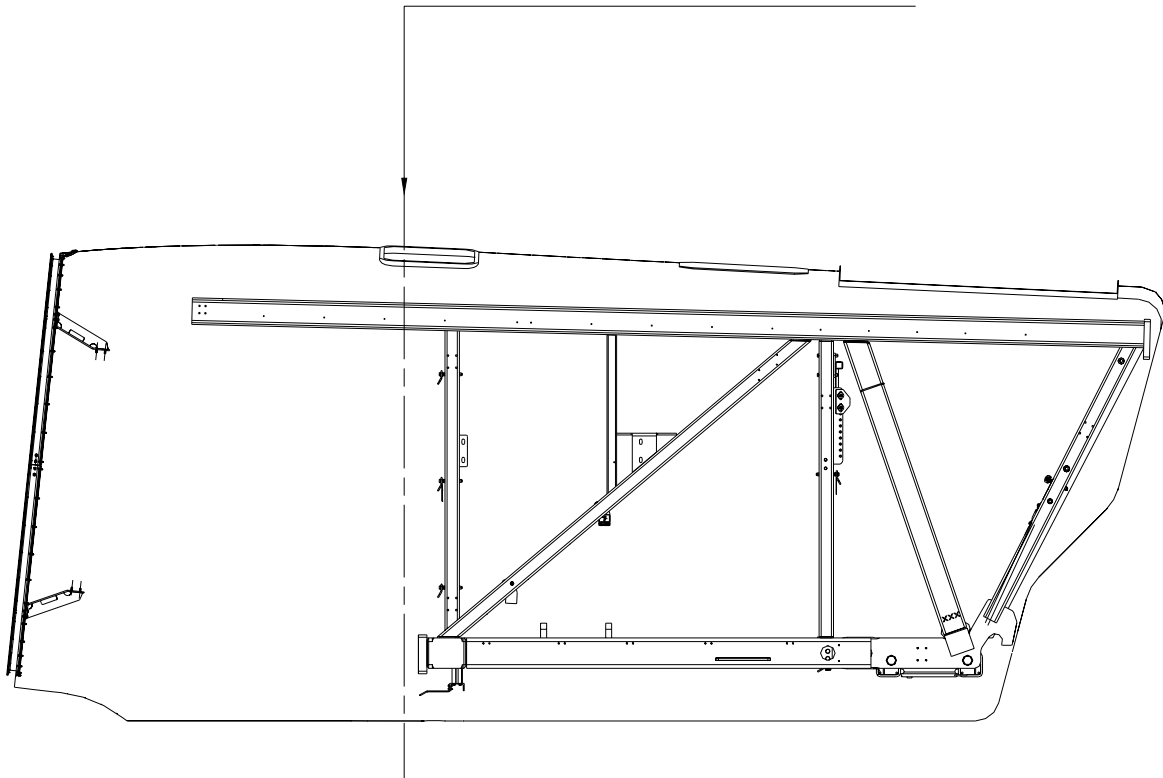

Internal crane for lifting gear stages, Max. work load is 12000 kg:

This operation is only to be done by authorized personnel.

