

APPENDIX A

Typical BMP Layouts

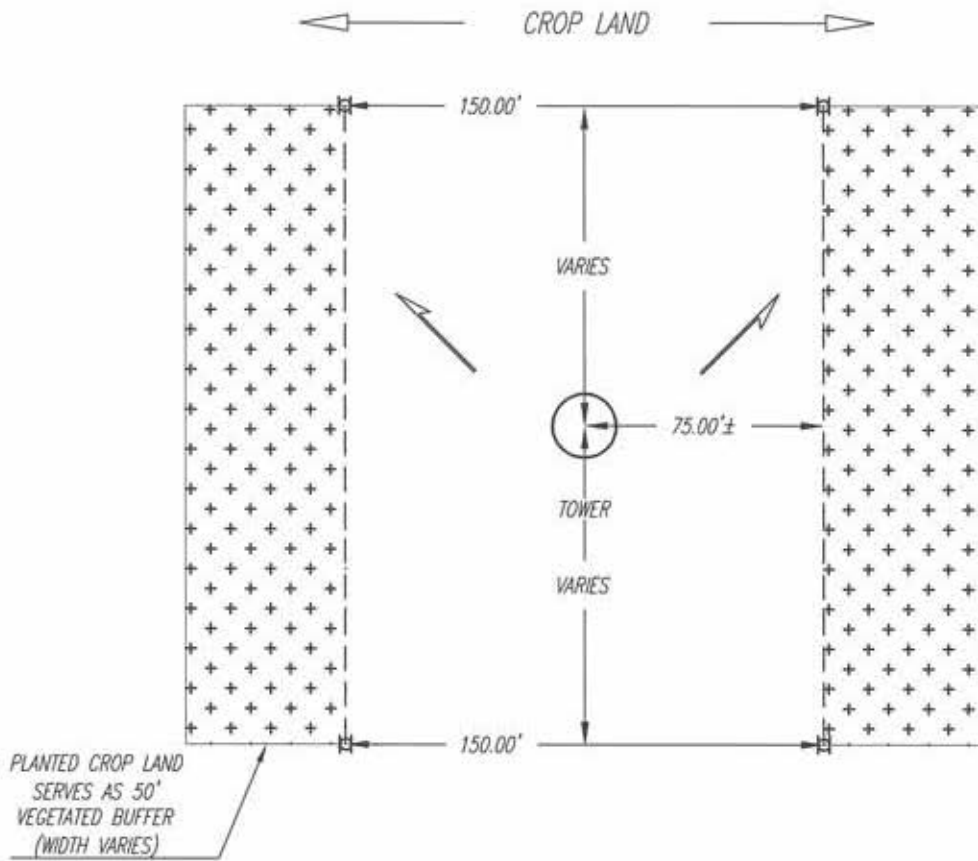

LEGEND	
BOUNDARY DELINEATOR POST	□
DRAINAGE FLOW DIRECTION	→
PLANTED CROP LAND AS VEGETATED BUFFER	+ + + + +
150' EASEMENT BOUNDARY	- - - - -

EROSION CONTROL PRODUCTS
 -DELINEATOR POSTS
 -MATS IF REQUIRED BY LAND OWNER

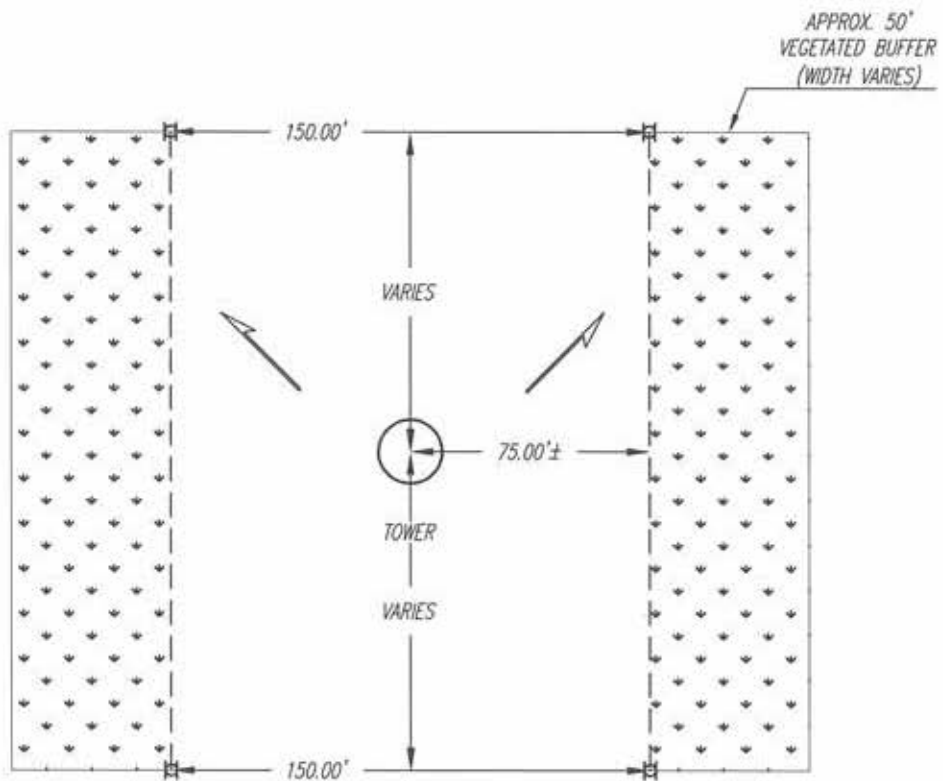

LEGEND	
BOUNDARY DELINEATOR POST	⊞
DRAINAGE FLOW DIRECTION	→
SEED FOR VEGETATED BUFFER	↓ ↓ ↓ ↓ ↓
150' EASEMENT BOUNDARY	- - - - -

EROSION CONTROL PRODUCTS
 -DELINEATOR POSTS
 -SEED FOR VEGETATED BUFFER



PROJ. NO. 15016
 DRAWN BY: CMC
 CHECKED BY: PJC
 DATE: 07/2015

TYPICAL PASTURE/GRASSLAND
SLOPES LESS THAN 8%

SHEET

2

OF 4

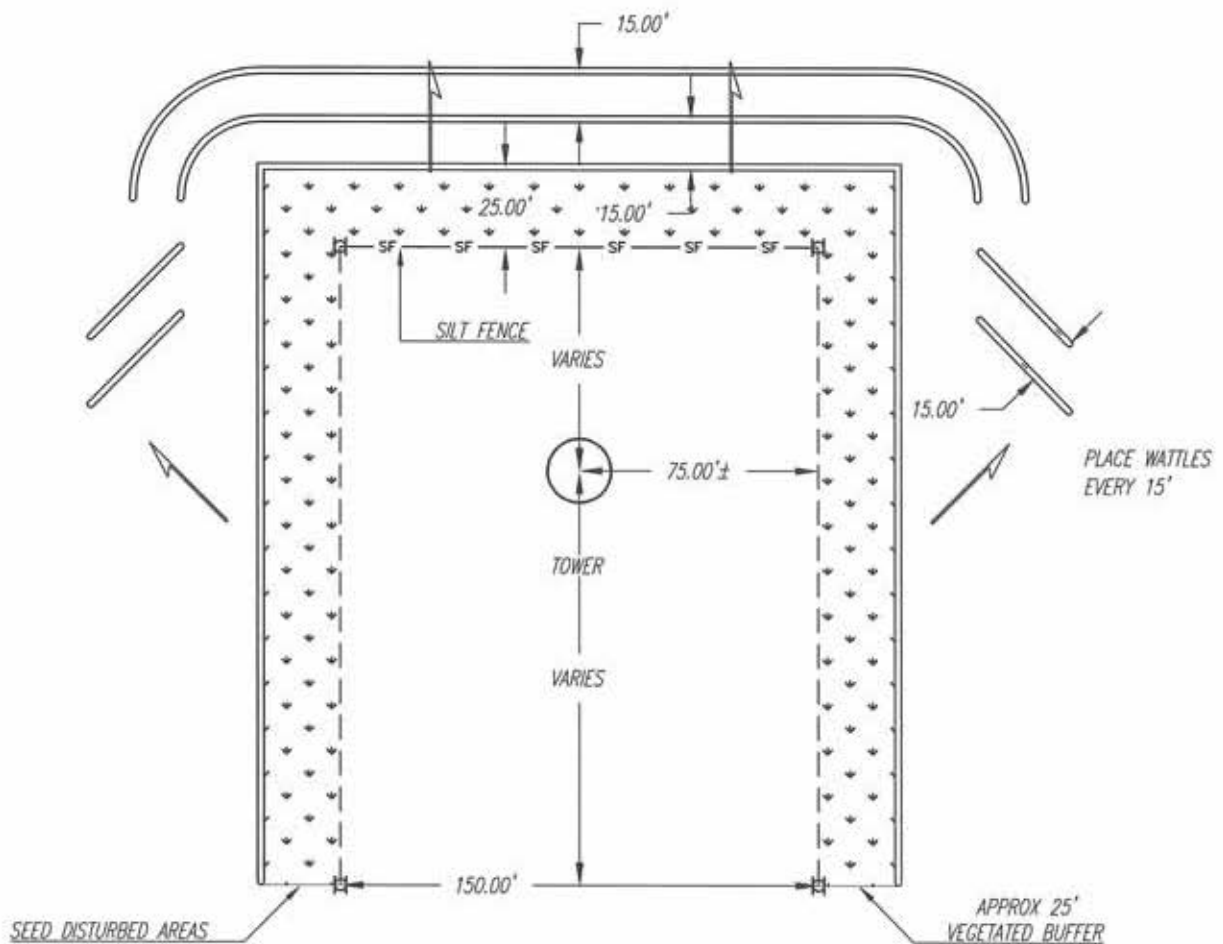

EROSION CONTROL PRODUCTS
 -HIGH FLOW SILT FENCE
 -EROSION CONTROL WATTLES
 -SEED FOR DISTURBED AREAS

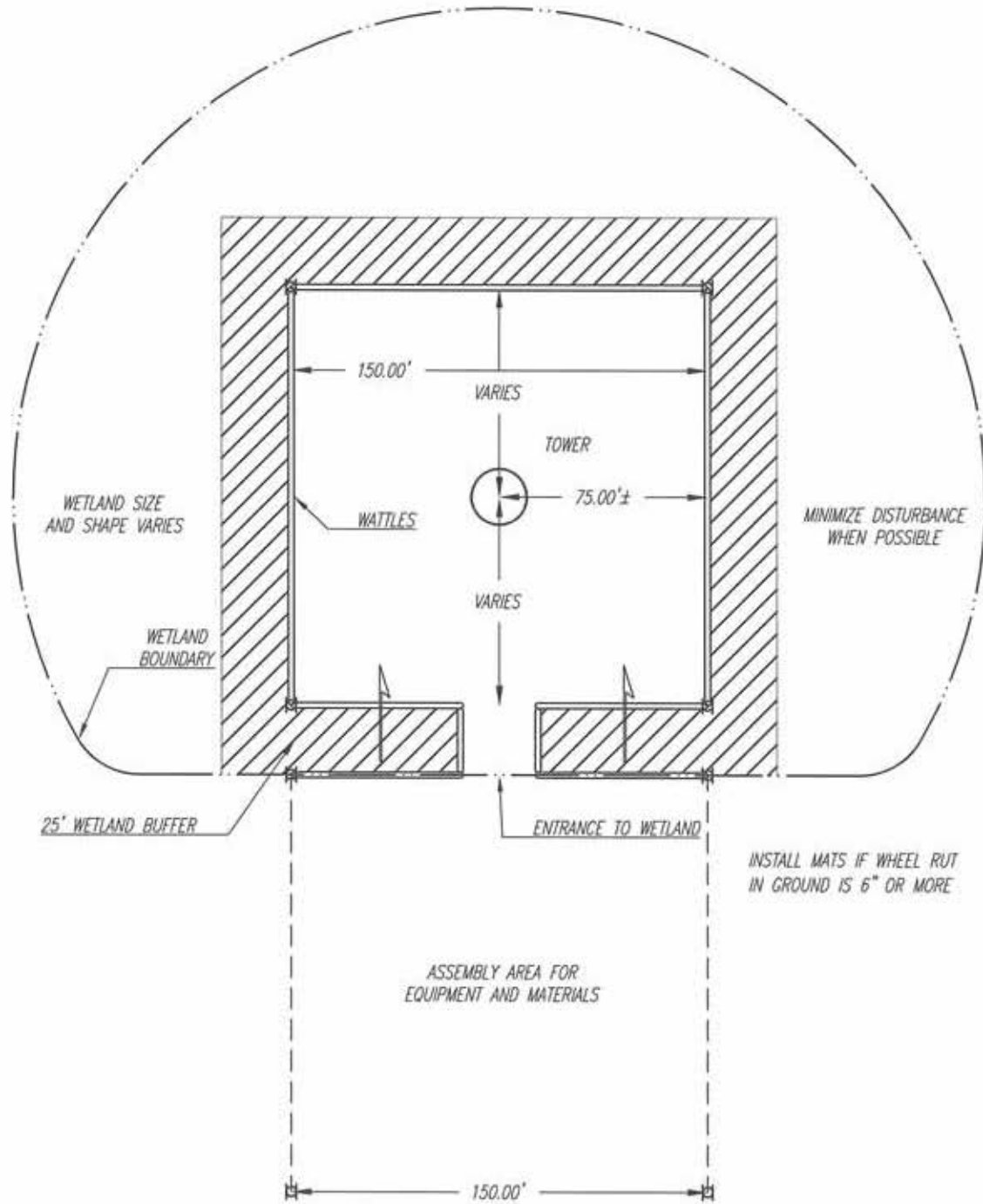

LEGEND	
DRAINAGE FLOW DIRECTION	
BOUNDARY DELINEATOR POST	
EROSION CONTROL WATTLE	
150' EASEMENT BOUNDARY	
WETLAND BOUNDARY	
25' WETLAND BUFFER	

EROSION CONTROL PRODUCTS
 - DELINEATOR POSTS
 - EROSION CONTROL WATTLES

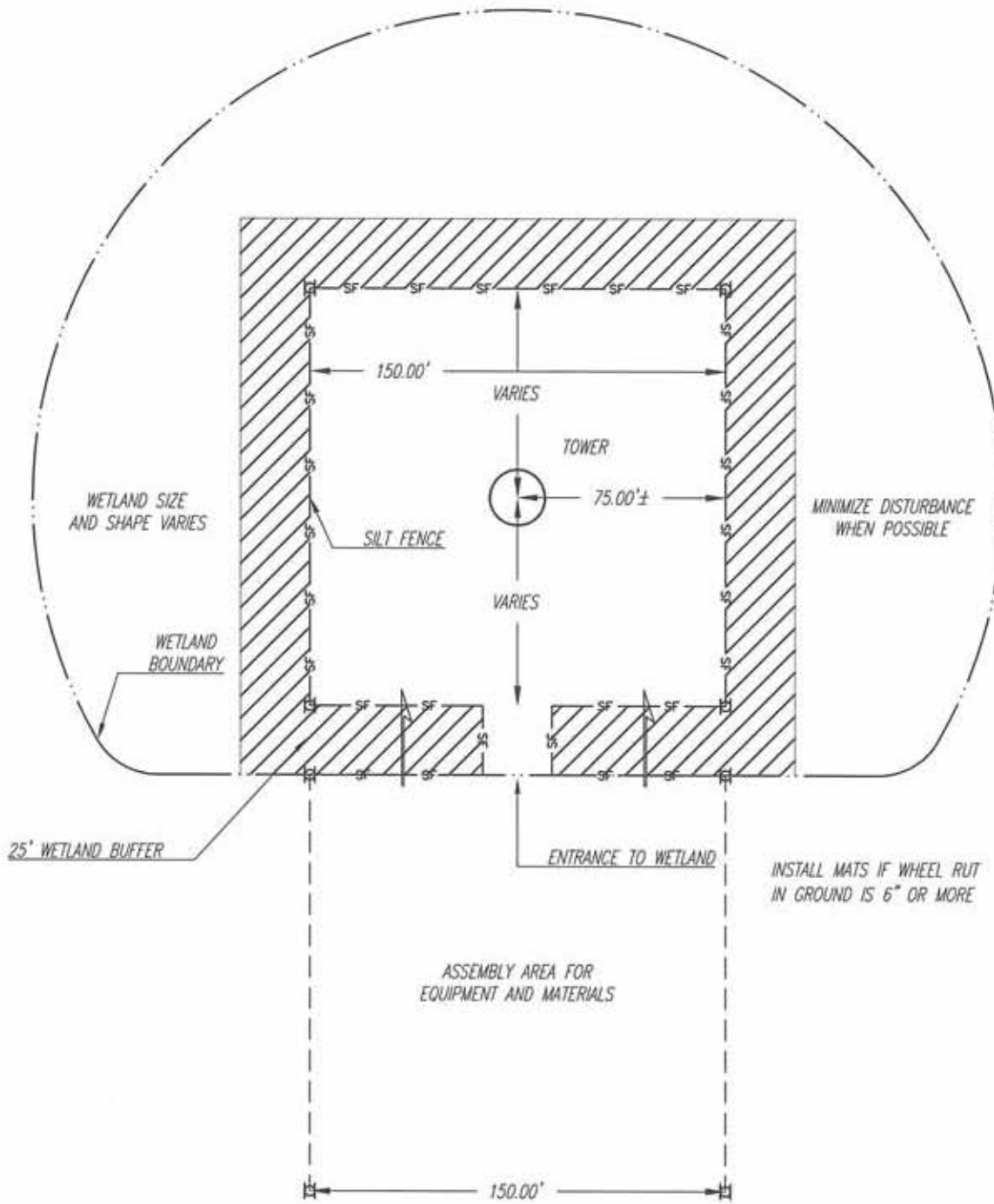

LEGEND	
DRAINAGE FLOW DIRECTION	
BOUNDARY DELINEATOR POST	
HIGH FLOW SILT FENCE	
150' EASEMENT BOUNDARY	
WETLAND BOUNDARY	
25' WETLAND BUFFER	

EROSION CONTROL PRODUCTS
 -DELINEATOR POSTS
 -HIGH FLOW SILT FENCE



PROJ. NO.:	15014
DRAWN BY:	CMC
CHECKED BY:	PJC
DATE:	07/2015

TYPICAL WETLAND

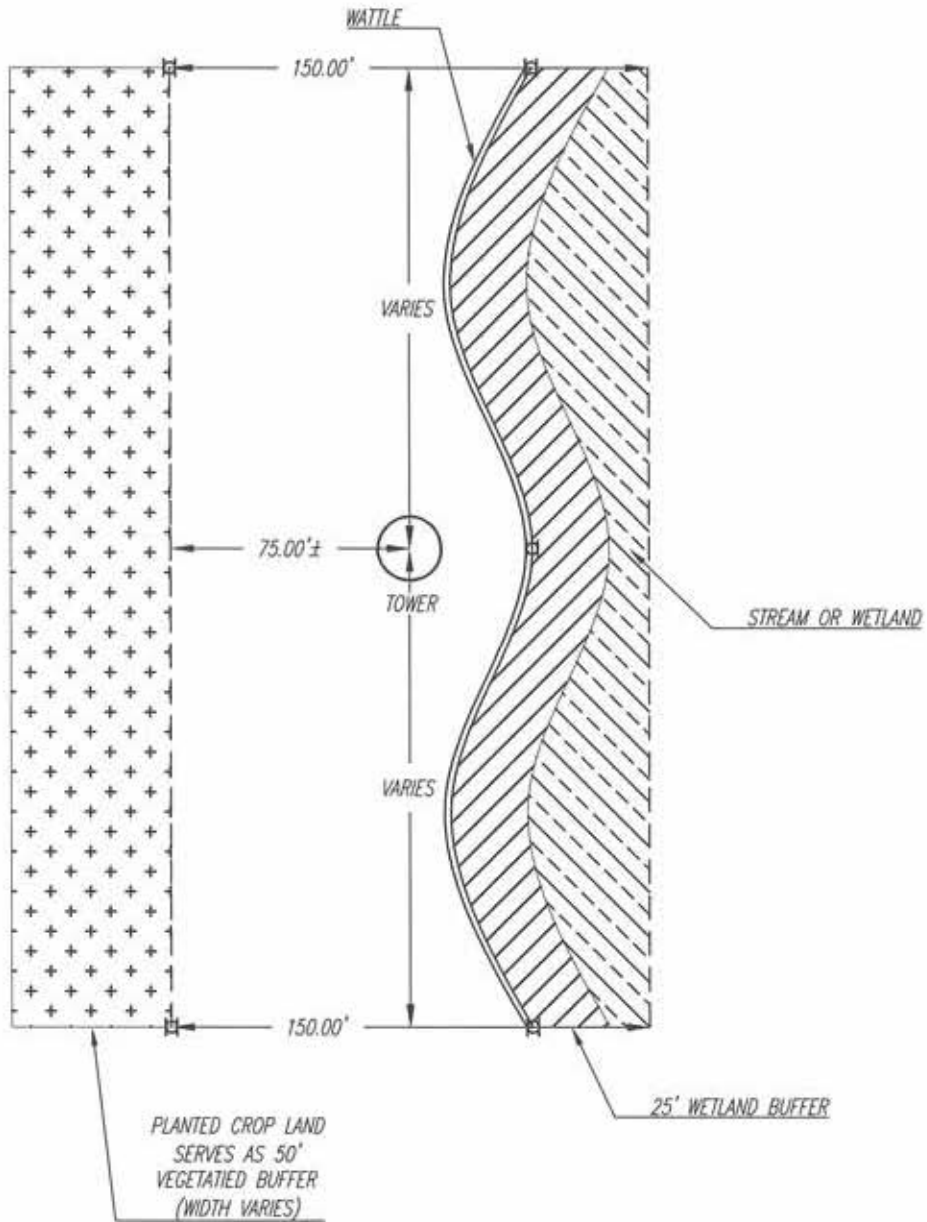

LEGEND	
DRAINAGE FLOW DIRECTION	
BOUNDARY DELINEATOR POST	
EROSION CONTROL WATTLE	
150' EASEMENT BOUNDARY	
STREAM	
25' WETLAND BUFFER	
CROP LAND BUFFER	

EROSION CONTROL PRODUCTS
 -DELINEATOR POSTS
 -HIGH FLOW SILT FENCE
 -EROSION CONTROL WATTLES