

## Attachment 31 Project Maps

Brookings – Twin Cities

Fargo – Twin Cities

Twin Cities – La Crosse

Bemidji – Grand Rapids

Chisago – Apple River

Blue Lake Wilmarth

BRIGO

North Mankato

Merriicourt System Upgrade

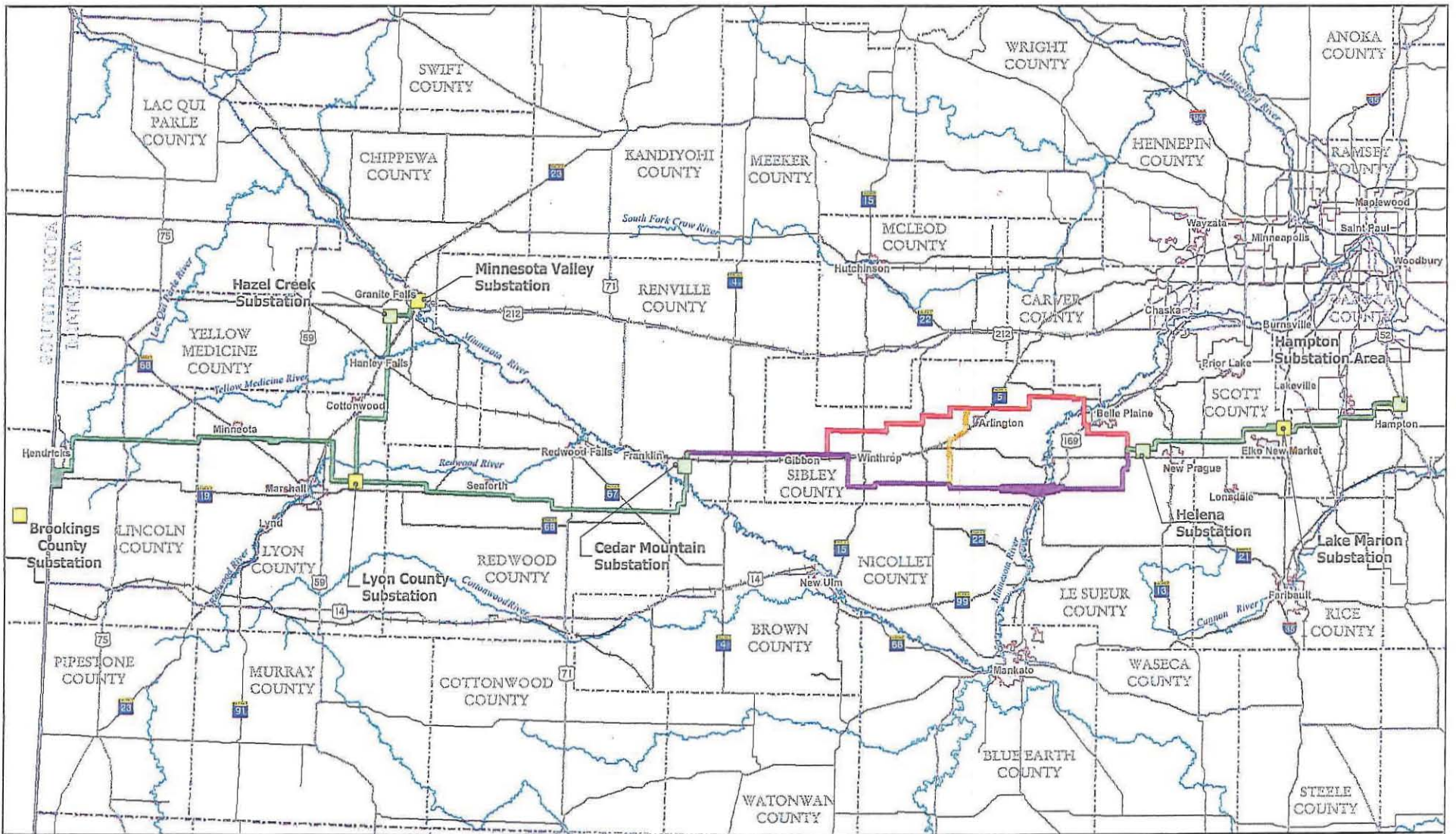

**CapX2020**

Delivering electricity you can rely on

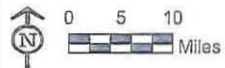

- Existing Project Substation
- Permitted Substation

**Routes**

- Approved Route
- Alternate Crossover
- Crossover
- Modified Preferred Route (MPR)

Overview Map  
Modified Preferred, Alternative Crossover and Crossover Route

Brookings-Hampton Route Maps  
PUC Docket Number ET2/TL-08-1474

Map Document Filename: 05/27/2010 10:48:00 AM Project: 085648022\_PWS\_Airmonitors.mxd 10/27/2010 10:48:00 AM 10/27/2010 10:48:00 AM



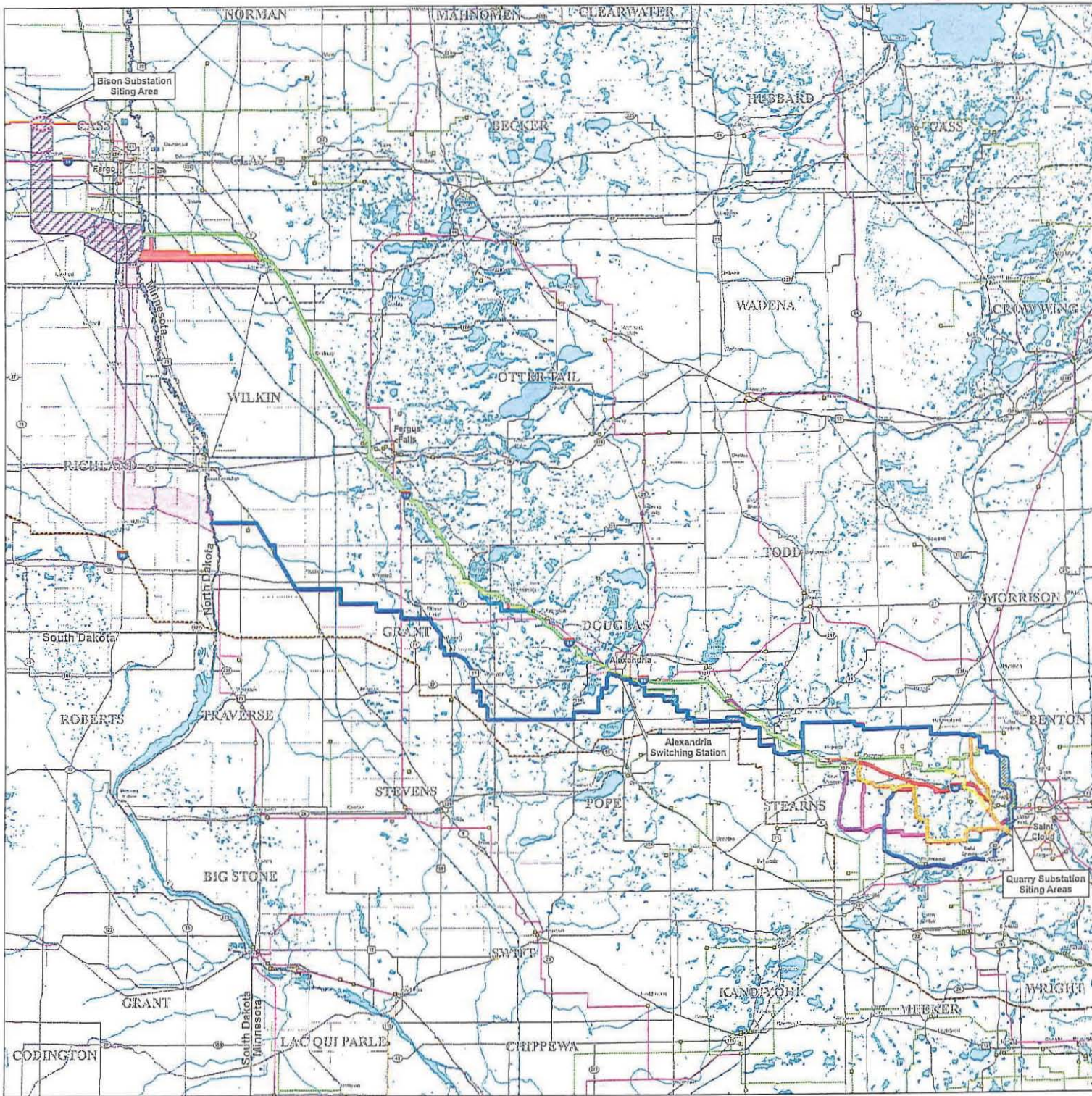

**Legend**

Applicants' Proposed Routes	Route G
Applicant Preferred Route	Route H
Route A	Public Route Options
Route E	Option 2c
Option 1	Option 4
Option 2b	Option 5
Option 3	Option 7
Option 6	Option 8
Applicants' Proposed New Route Areas	Option 9
ATF Identified Routes	Option 10
Route B	Option 11
Route C	Option 12
Route D	
Route F	

Bison Substation Siting Area  
 ND Corridor Option 1  
 ND Corridor Option 2

**Existing Transmission Lines**  
Voltage (kV)

400	230
345	115
250	69

Existing Substations

**Roads**

- Interstate
- US Highway
- State Highway
- County Road / Secondary Road
- Railroad
- River / Stream
- Lake

State Boundary  
 County Boundary  
 Municipalities

**FARGO TO ST. CLOUD**  
**345 kV Transmission**  
**Line Project**

Date: 07/26/10	Revised: 07/26/10
\\NCS\dev\proj\345\Chk\Final_Ard\070510\Map\Map_XCL_CAPX_Fargo_Map_DV_072610.mxd	Drawn by: MLTEICHERT



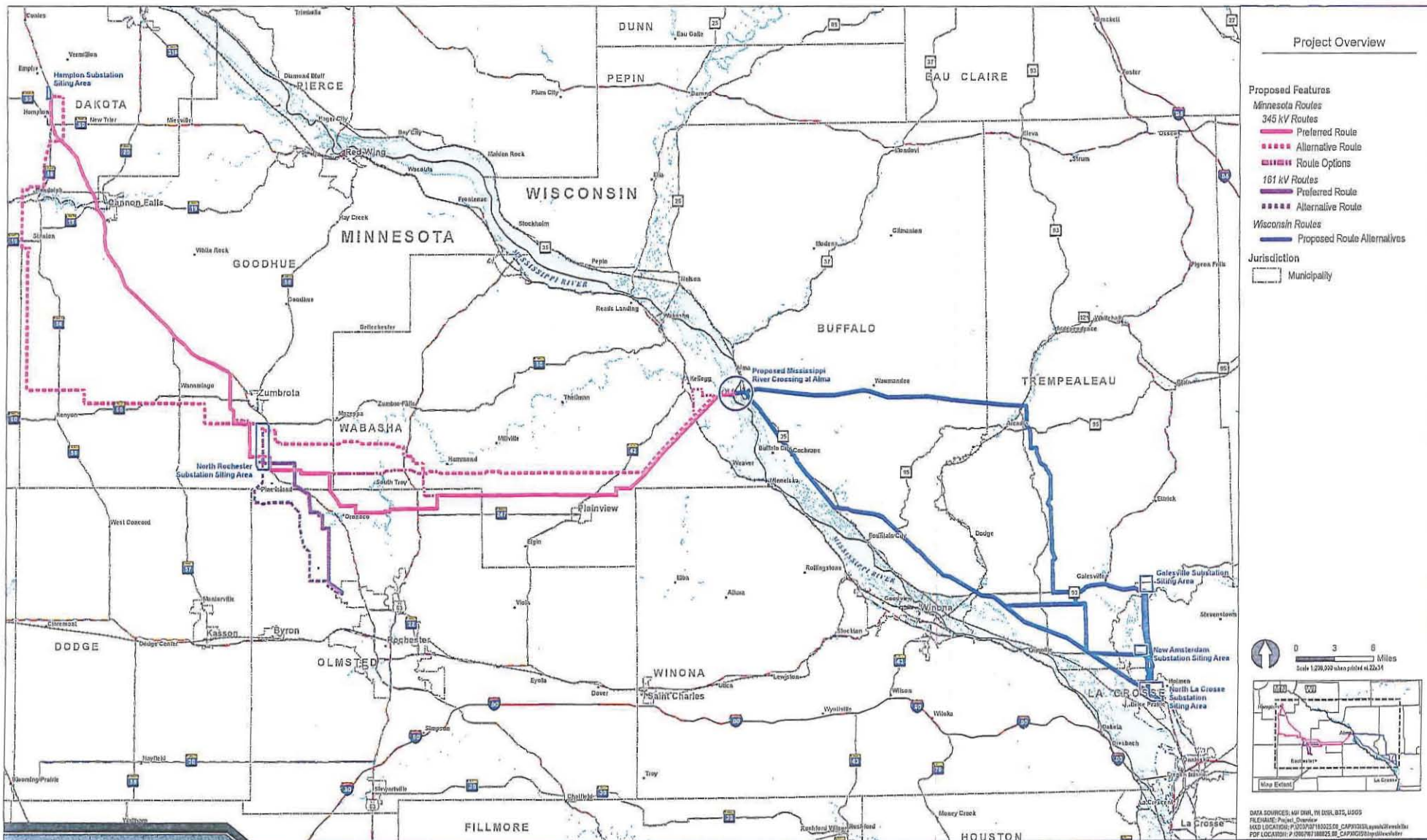

**Project Overview**

- Proposed Features**
- Minnesota Routes**
    - 345 kV Routes
      - Preferred Route
      - Alternative Route
    - 161 kV Routes
      - Preferred Route
      - Alternative Route
  - Wisconsin Routes**
    - Proposed Route Alternatives
  - Jurisdiction**
    - Municipality

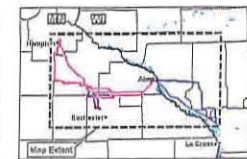
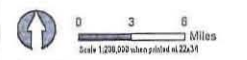

DATA SOURCES: MNDNR, WI DNR, BLS, USGS  
 RELEASED: Project Owner  
 EXD LOCATION: P:\2013\180225\_DE\_CAP\GIS\Layers\Map\wshdr  
 PDF LOCATION: P:\2013\180225\_DE\_CAP\GIS\Layers\Map\wshdr

**CapX 2020**

Hampton • Rochester • La Crosse 345 kV Transmission Project

*Project Overview*

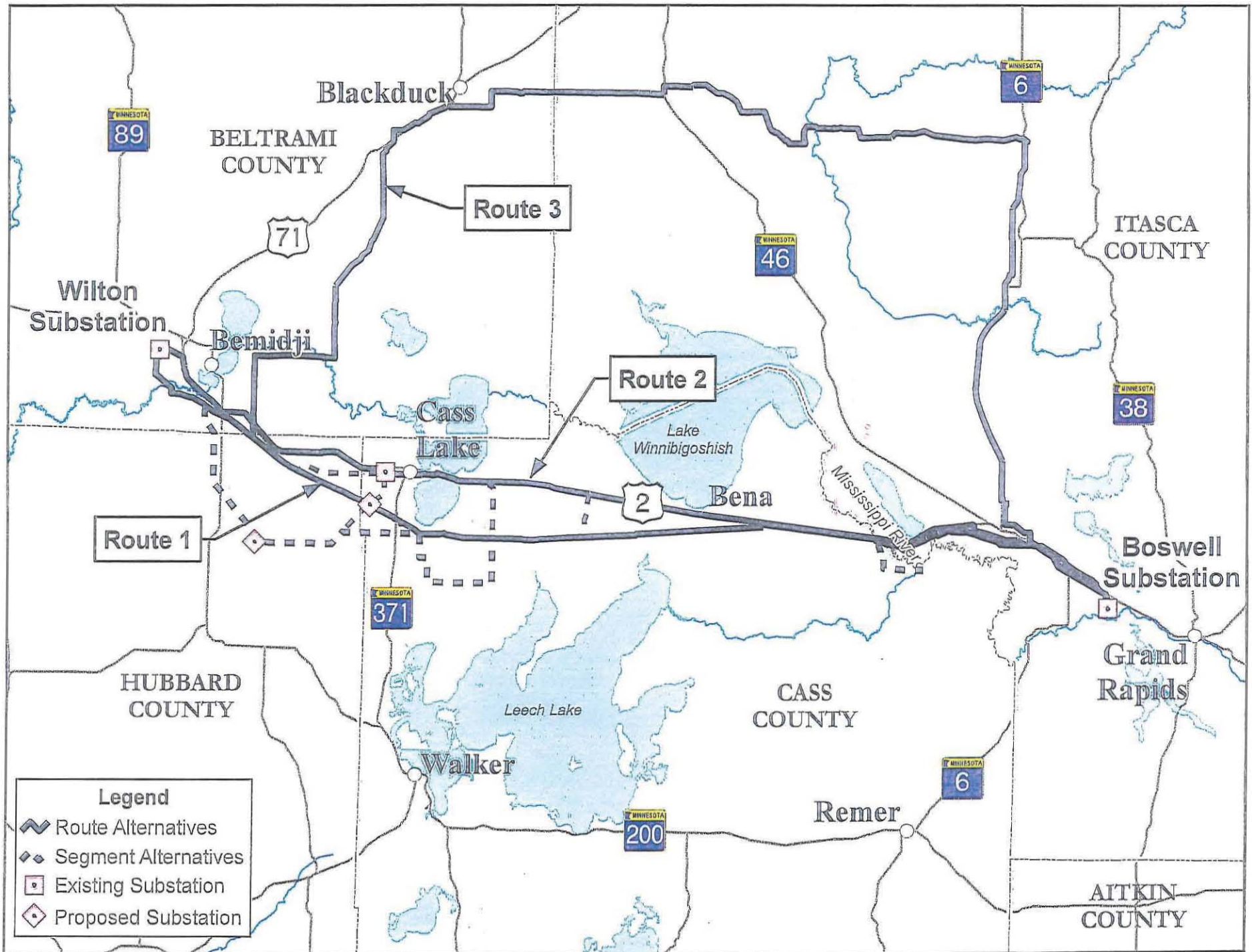



Map Document: (N:\gisproj\0679407616\map\_docs\mxd\route\_app\_maps\figure1\_overview\_map\_rn\_wi.mxd)  
11/20/2008 3:59:44 PM

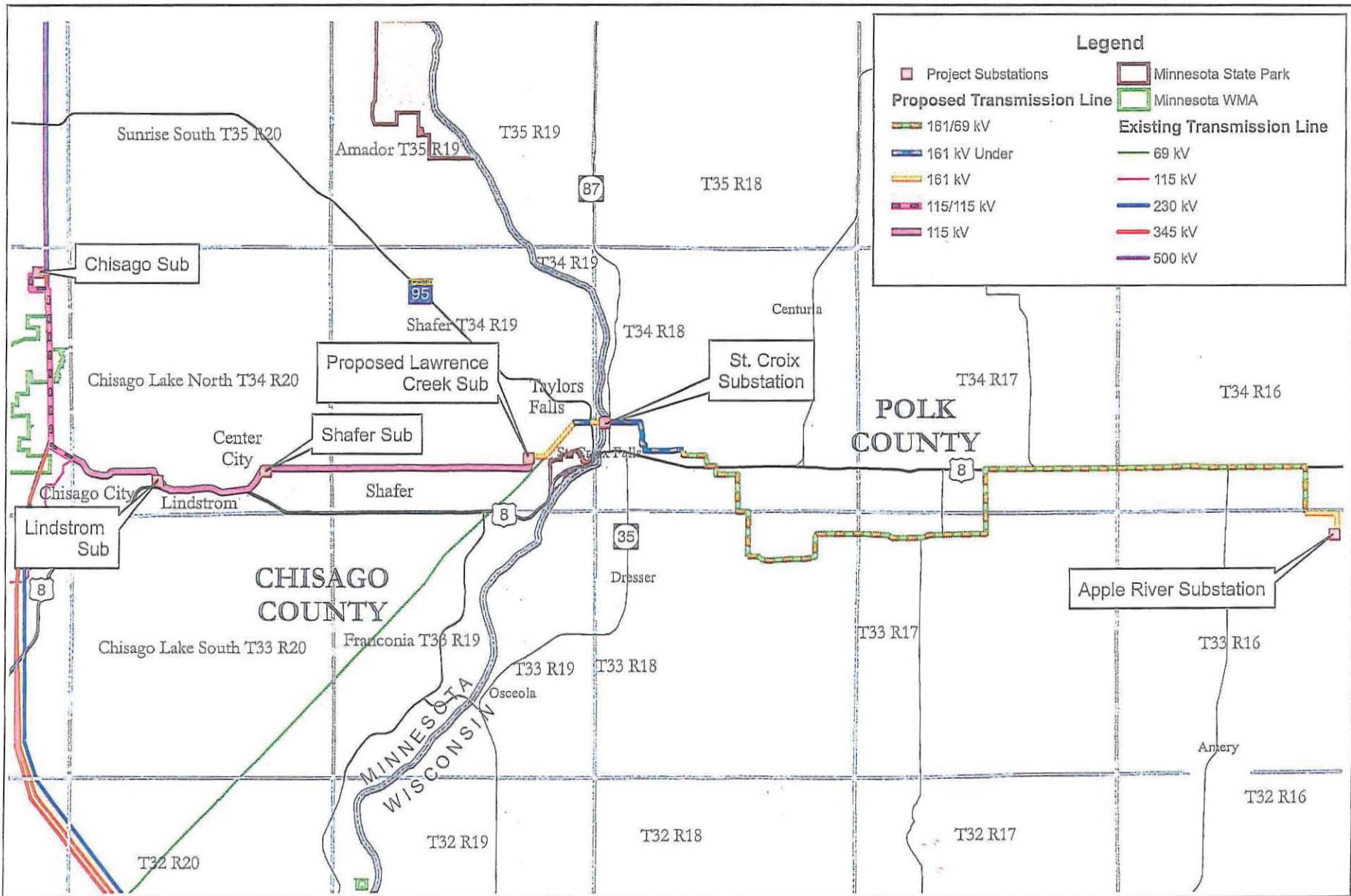

Figure 1 - Project Overview Map  
Chisago County to Apple River 115 kV/161 kV Transmission Line Project  
Xcel Energy  
Chisago County, Minnesota



0 0.75 1.5  
Miles



# Blue Lake ~ Wilmarth ~ Fieldon Series ~ Lakefield Gen ~ Lakefield Junction

## 1- Line Diagram

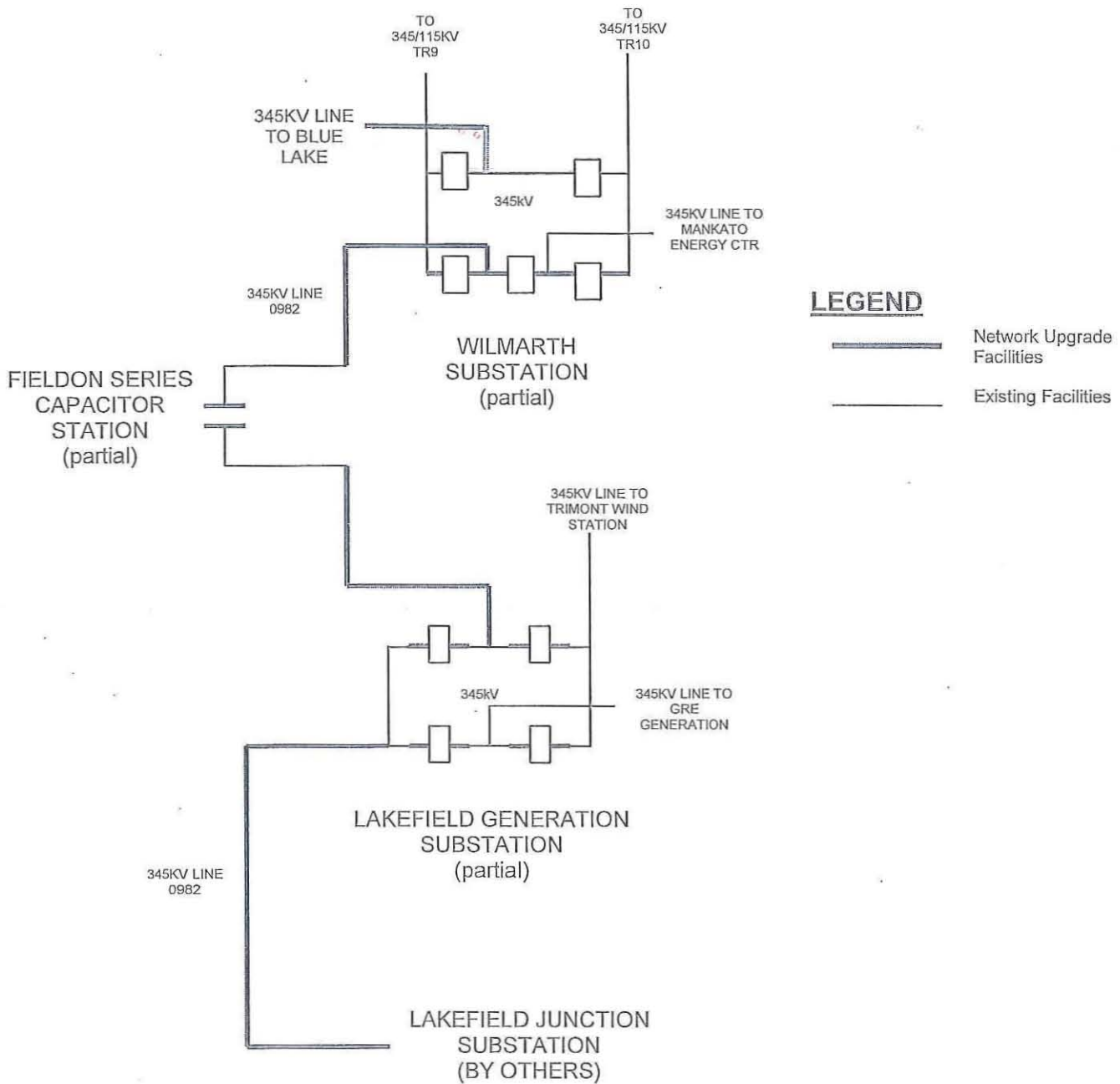

Application to the  
Minnesota Public Utilities Commission  
for Certificates of Need

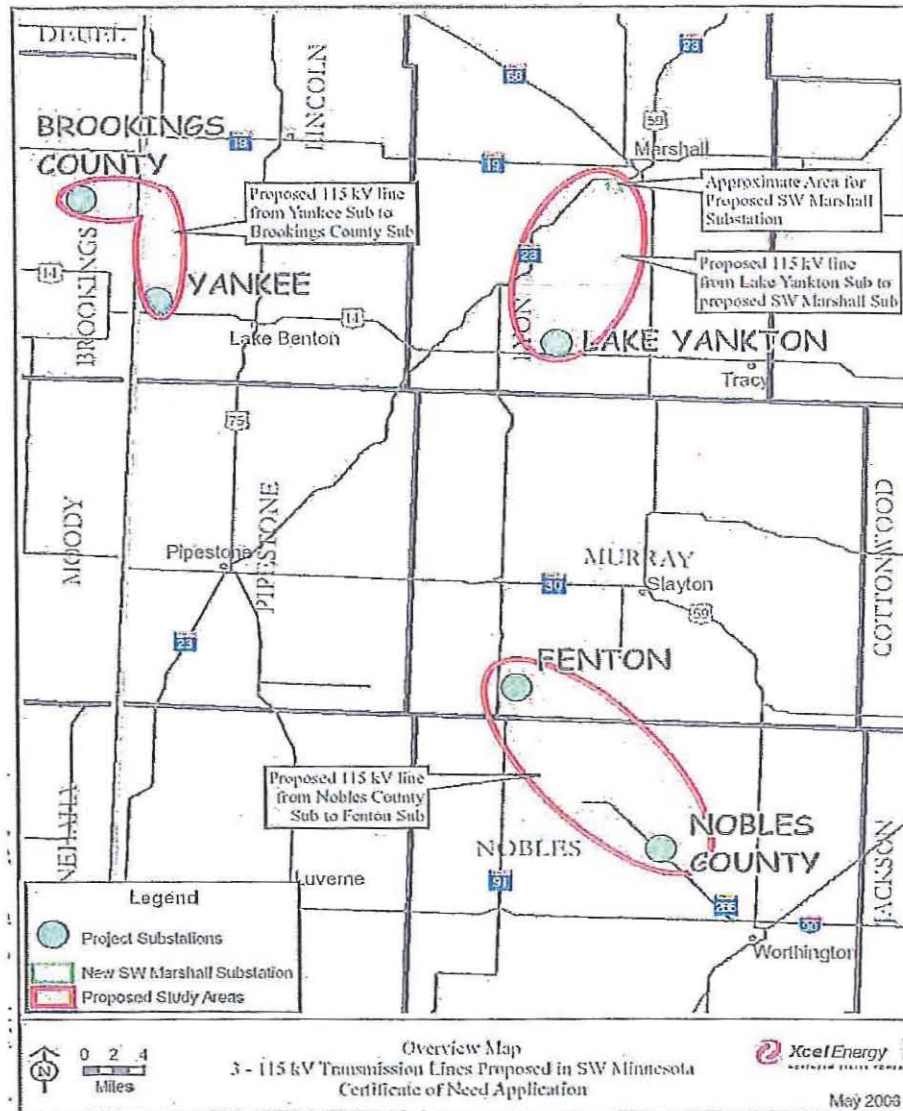

Three 115 kV Transmission Lines  
Buffalo Ridge Area of Southwestern Minnesota

Docket No. E002/CN-06-154



# North Mankato Project

2.If South Helena site is approved for Helena Substation (Current Plan)

**SCOPE**

"Construct Le Sueur 69 kV breaker substation (now called Kelso)

"Construct Helena 345/115/ 69 kV transformer substation at south Helena substation

"Permit and build 5 mile of 69 kV double circuit transmission line from Helena south to St. Thomas

"CON not required

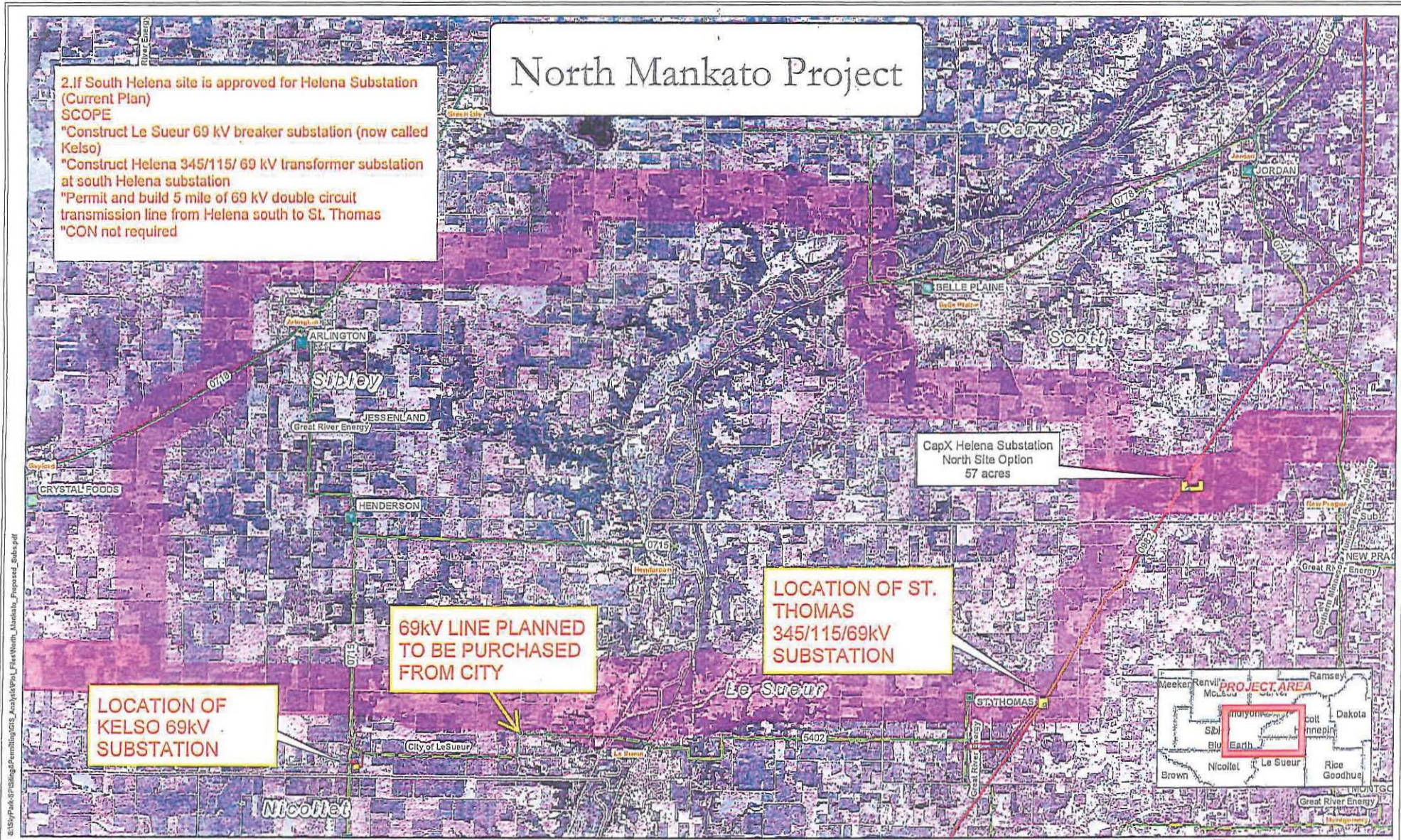

S:\Sib\Permitting\GIS\_Analysis\PA\_LeSueur\LeSueur\_Proposed\_subst.pdf

LOCATION OF  
KELSO 69kV  
SUBSTATION

69kV LINE PLANNED  
TO BE PURCHASED  
FROM CITY

LOCATION OF ST.  
THOMAS  
345/115/69kV  
SUBSTATION

CapX Helena Substation  
North Site Option  
57 acres

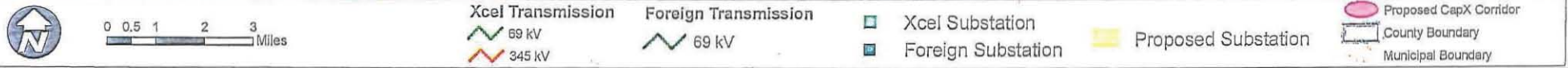



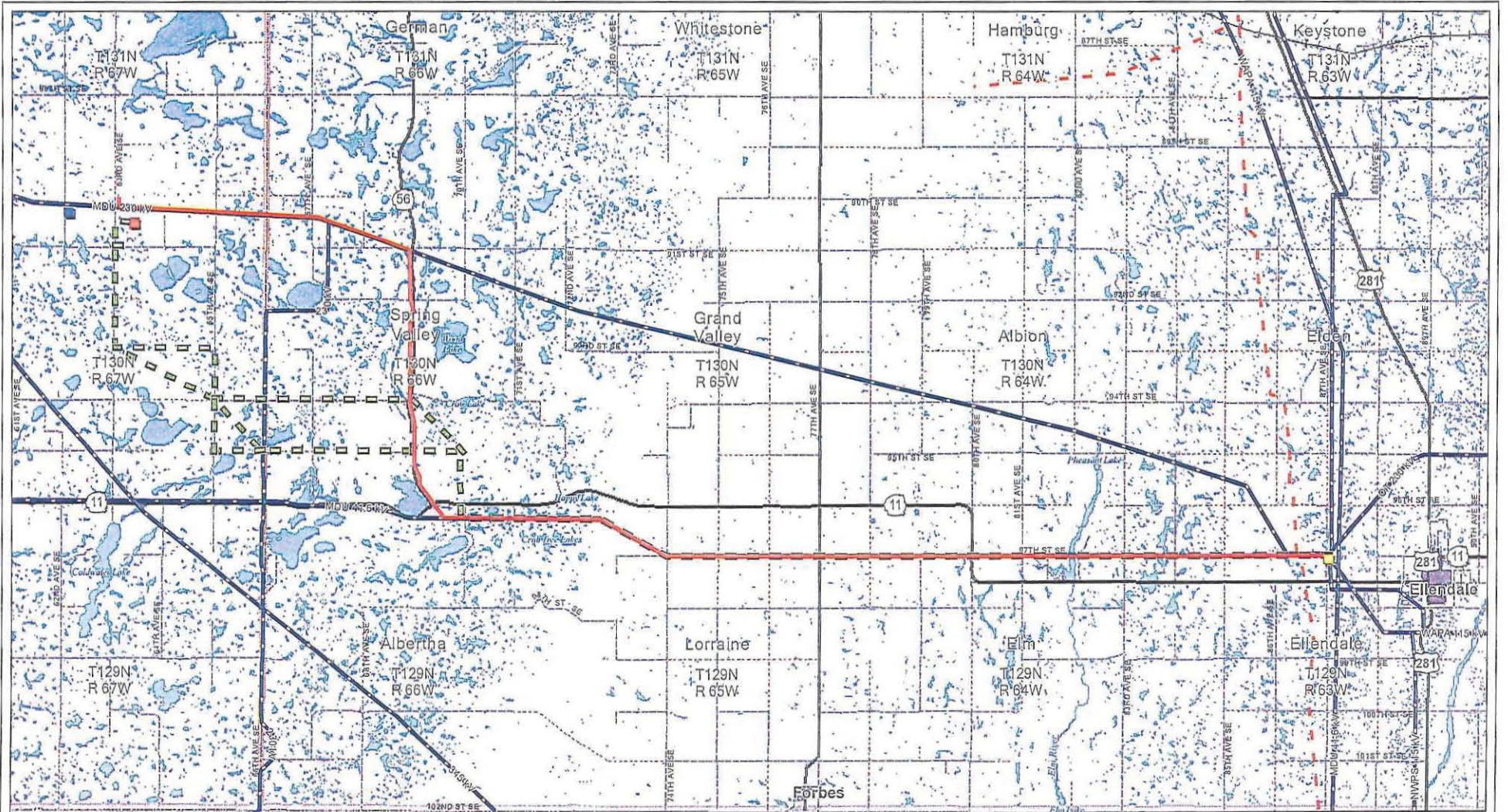

- |   |  |                            |                  |                 |
|---|--|----------------------------|------------------|-----------------|
| Proposed Route                                | Existing MDU Ellendale Jct. Substation | Existing Transmission Line | Highway          | Stream          |
| Alternate Route                               | Forbes Substation                      | Existing Gas Pipeline      | In-Use Railroad  | Wetland         |
| Alternate MDU Merricourt Wind Farm Substation | Incorporated Area                      | Graded/Drained/Gravel      | Trail/Unimproved | County Boundary |
| Proposed MDU Merricourt Wind Farm Substation  |  |                            |                  |                 |

Route Strategy Index Map  
 Montana-Dakota Utilities Co.  
 Merricourt Wind Farm to  
 Ellendale Project



Map Document: D:\merricourt\GIS\MapDocs\MapDocs\MerricourtWindFarmRouteStrategyIndexMap.mxd, Project: 10/15/2010, File: T:\GIS\MapDocs\MerricourtWindFarmRouteStrategyIndexMap.mxd, Date: 10/15/2010