

EAST RIVER

ELECTRIC POWER COOPERATIVE

121 Southeast First St.
Madison, SD 57042

P.O. Box 227

Telephone (605) 256-4536

RECEIVED

FEB 27 2004

**SOUTH DAKOTA PUBLIC
UTILITIES COMMISSION**

February 25, 2004

for 605-256-8058

Ms. Pam Bonrud, Executive Director
South Dakota Public Utilities Commission
500 East Capitol Avenue
Pierre, SD 57501-5070

Dear Ms. Bonrud:

Attached for the Public Utilities Commission's review and consideration are twelve copies of East River Electric Power Cooperative's (East River) Application for its proposed Sioux Falls Area 115 KV Transmission Upgrade Project. The proposed project would convert approximately 36 miles of existing East River 69 KV transmission line and 7 existing East River 69 KV distribution substations to 115 KV. The multi-year project is needed for East River to be able to continue to adequately and reliably serve the growing electrical needs of its member distribution systems in the Sioux Falls area.

The Application was prepared by East River in accordance with the requirements set forth in South Dakota Codified Law (SDCL) 49-41B. East River respectfully requests the Commission begin the Application review and decision process for the proposed project. If additional information or clarification is needed, please contact either myself or Dan Wall, Manager of Transmission and Engineering Services.

Sincerely,

Jim Edwards
Assistant General Manager
Operations

JE/jc

cc: Jeff Nelson



EL 04-009

RECEIVED

FEB 27 2004

SOUTH DAKOTA PUBLIC
UTILITIES COMMISSION

SOUTH DAKOTA PUBLIC UTILITIES COMMISSION

APPLICATION

FOR

SIOUX FALLS AREA 115 KV TRANSMISSION

UPGRADE PROJECT

Prepared by:

East River Electric Power Cooperative, Inc.
121 Southeast First Street
Madison, South Dakota

February 2004

CONTENTS

| <u>Section</u> | <u>Page</u> |
|---|-------------|
| ACRONYMS AND ABBREVIATIONS | v |
| 1.0 APPLICATION PREFACE..... | 1 |
| 2.0 APPLICATION | 3 |
| 2.1 NAME OF PARTICIPANTS (SDAR 20:10:22:06)..... | 3 |
| 2.2 NAME OF OWNER AND MANAGER (SDAR 20:10:22:07)..... | 4 |
| 2.3 DESCRIPTION OF THE NATURE AND LOCATION OF THE FACILITY (SDCL 49-41b-11 (2) | 4 |
| 2.4 PURPOSE OF FACILITY (SDAR 20:10:22:08)..... | 6 |
| 2.5 ESTIMATED COST OF FACILITY (SDAR 20:10:22:09) | 6 |
| 2.6 DEMAND FOR FACILITY (SDAR 20:10:22:10) | 7 |
| 2.7 GENERAL SITE DESCRIPTION (SDAR 20:10:22:11)..... | 8 |
| 2.7.1 Part One | 8 |
| 2.7.2 Part Two | 9 |
| 2.7.3 Part Three..... | 10 |
| 2.7.4 Part Four..... | 10 |
| 2.7.5 Part Five | 11 |
| 2.7.6 Part Six..... | 11 |
| 2.8 PROJECT ALTERNATIVES (SDAR 20:10:22:12)..... | 12 |
| 2.9 ENVIRONMENTAL INFORMATION (SDAR 20:10:22:13) | 13 |
| 2.10 EFFECT ON PHYSICAL ENVIRONMENT (SDAR 20:10:22:14)... | 15 |
| 2.10.1 Regional Land Forms | 15 |
| 2.10.2 Topography..... | 15 |
| 2.10.3 Geologic Features | 16 |
| 2.10.4 Economic Deposits | 16 |
| 2.10.5 Soil Type..... | 16 |
| 2.10.6 Potential for Erosion and Sedimentation..... | 16 |
| 2.10.7 Seismic Risks, Subsidence Potential, and Slope Instability..... | 16 |
| 2.10.8 Geological Constraints..... | 16 |
| 2.11 HYDROLOGY (SDAR 20:10:22:15) | 17 |
| 2.11.1 Hydrologic Map..... | 17 |
| 2.11.2 Effect on Current Planned Water Uses..... | 17 |
| 2.11.3 Surface and Groundwater Use by Proposed Facility | 17 |

| | | |
|--------|--|----|
| 2.11.4 | Aquifer Use by Proposed Facility | 17 |
| 2.11.5 | Water Storage, Reprocessing, and Cooling by Proposed Facility..... | 17 |
| 2.11.6 | Deep Well Injection Use by Proposed Facility | 17 |
| 2.12 | EFFECT ON TERRESTRIAL ECOSYSTEMS (SDAR 20:10:22:16) | 17 |
| 2.12.1 | Effect on Wildlife | 18 |
| 2.12.2 | Effect on Vegetation | 18 |
| 2.13 | EFFECT ON AQUATIC ECOSYSTEMS (SDAR 20:10:22:17) | 18 |
| 2.14 | LAND USE (SDAR 20:10:22:18) | 19 |
| 2.14.1 | Land Use Map | 19 |
| 2.14.2 | Homes and Persons Displaced..... | 19 |
| 2.14.3 | Land Use Compatibility | 19 |
| 2.14.4 | Effect on Land Use | 19 |
| 2.15 | LOCAL LAND USE CONTROLS (SDAR 20:10:22:19)..... | 20 |
| 2.16 | WATER QUALITY (SDAR 20:10:22:20)..... | 20 |
| 2.17 | AIR QUALITY (SDAR 20:10:22:21)..... | 21 |
| 2.18 | TIME SCHEDULE (SDAR 20:10:22:22)..... | 21 |
| 2.19 | COMMUNITY IMPACT (SDAR 20:10:22:23)..... | 21 |
| 2.19.1 | Forecast of Socioeconomic Impact..... | 21 |
| 2.19.2 | Property and Other Tax Impacts..... | 22 |
| 2.19.3 | Forecast of Agricultural Impacts | 22 |
| 2.19.4 | Forecast of Population and Community Impacts | 22 |
| 2.19.5 | Forecast of Transportation Impacts | 22 |
| 2.19.6 | Forecast of Cultural Resource Impacts..... | 22 |
| 2.20 | EMPLOYMENT ESTIMATES (SDAR 20:10:22:24)..... | 23 |
| 2.21 | FUTURE ADDITIONS AND MODIFICATIONS (SDAR 20:10:22:25) | 23 |
| 2.22 | RIGHT-OF-WAY ACCESS, CLEARING, WEED CONTROL, AND RESTORATION (SDAR 20:10:22:34)..... | 23 |
| 2.22.1 | Vegetation Clearing | 23 |
| 2.22.2 | Soils | 23 |
| 2.22.3 | Herbicides and Sterilants (Weed Control)..... | 23 |
| 2.22.4 | Construction Site Access..... | 23 |
| 2.22.5 | Waster Disposal..... | 24 |
| 2.22.6 | Restoration and Revegetation | 24 |

| | | |
|--------|---|----|
| 2.23 | TRANSMISSION FACILITY DESIGN AND CONSTRUCTION (SDAR 20:10:22:35) | 24 |
| 2.23.1 | Configuration of Poles | 24 |
| 2.23.2 | Line Switches..... | 25 |
| 2.23.3 | Conductor Configuration | 25 |
| 2.23.4 | Proposed Transmission Site and Major Alternatives | 26 |
| 2.23.5 | Reliability and Safety | 26 |
| 2.23.6 | Right-of-Way or Condemnation Requirements | 26 |
| 2.23.7 | Necessary Clearing Activities | 26 |
| 2.23.8 | Configuration of Underground Facilities..... | 26 |
| 2.24 | ADDITIONAL INFORMATION IN APPLICATION (SDAR 20:10:22:36) | 27 |
| 2.25 | TESTIMONY AND EXHIBITS (SDAR 20:10:22:39) | 27 |

EXHIBITS

- 1 PROJECT MAP
- 2 PROJECT HIGH VOLTAGE SOURCE ADDITIONS
- 3 PROJECT MAP WITH PARTS IDENTIFIED
- 4 PART 1 LOCATION MAP
- 4a PART 1 AERIAL MAP
- 4b PART 1 TOPOGRAPHIC MAP
- 5 PART 2 LOCATION MAP
- 5a PART 2 AERIAL MAP
- 5b PART 2 TOPOGRAPHIC MAP
- 6 PART 3 LOCATION MAP
- 6a PART 3 AERIAL MAP
- 6b PART 3 TOPOGRAPHIC MAP
- 7 PART 4 LOCATION MAP
- 7a PART 4 AERIAL MAP
- 7b PART 4 TOPOGRAPHIC MAP
- 8 PART 5 LOCATION MAP
- 8a PART 5 AERIAL MAP
- 8b PART 5 TOPOGRAPHIC MAP
- 9 PART 6 LOCATION MAP
- 9a PART 6 AERIAL MAP
- 9b PART 6 TOPOGRAPHIC MAP
- 10 PHOTO OF EXISTING LINE CROSSING CROP LAND
- 11 PHOTO OF EXISTING LINE INTERACTION WITH RESIDENTIAL AREA
- 12 PHOTO OF WESTERN AREA POWER ADMINISTRATIONS SIOUX FALLS SUBSTATION
- 13 PHOTO OF TYPICAL 69 kV LINE STRUCTURE WITH SUSPENSION INSULATORS
- 14 PHOTO OF TYPICAL 115 kV TRANSMISSION STRUCTURE WITH SIDE MOUNT INSULATORS
- 14a TECHNICAL DRAWING OF TRANSMISSION STRUCTURE WITH SIDE MOUNT INSULATORS
- 15 PHOTO OF TWO POLE LINE STRUCTURE
- 15a TECHNICAL DRAWING OF TWO POLE TRANSMISSION STRUCTURE
- 16 PHOTO OF THREE WAY SWITCH
- 17 PHOTO OF DOUBLE CIRCUIT TRANSMISSION STRUCTURE
- 18 PHOTO DIPICTING EXISTING LINE PROXIMETRY TO HIGHWAY ROW
- 18a TECHNICAL DRAWING OF SINGLE POLE LINE STRUCTURE WITH WISHBONE CROSS ARMS
- 19 MINNEHAHA COUNTY LAND USE MAP
- 20 LINCOLN COUNTY LAND USE MAP
- 21 PHOTO OF THREE WAY LINE SWITCH
- 21a TECHNICAL DRAWING OF 115 kV THREE WAY LINE SWITCH
- 22 PHOTO OF 69 kV LINE SWITCH
- 22a TECHNICAL DRAWING OF 115 kV LINE SWITCH

ACRONYMS AND ABBREVIATIONS

| | |
|--------------|---|
| ACSR | Aluminum conductor steel reinforced |
| East River | East River Electric Power Cooperative |
| kV | Kilovolt |
| MCM | Million circular mills |
| MW | Megawatts |
| OPGW | Optical Ground Wire |
| PUC | Public Utilities Commission |
| ROW | Right-of-way |
| RUS | Rural Utilities Service |
| SDAR | South Dakota Administrative Rule |
| SDCL | South Dakota Codified Law |
| Section Line | Public Land Survey Section Line |
| SPCC | Spill Prevention Control and Counter Measure Plan |
| WAPA | Western Area Power Administration |

1.0 APPLICATION PREFACE

East River Electric Power Cooperative, Inc. (East River) is proposing to upgrade its existing 69,000 volt (69 kV) overhead electric transmission system located on the northeast, east and south sides of Sioux Falls, South Dakota to 115,000 volts (115 kV). This entire project is referred to in this application as the "Sioux Falls Area 115 kV Transmission Upgrade Project " or as the "Project".

The Sioux Falls Area 115 kV Transmission Upgrade Project will include:

- Converting approximately 36 miles of existing 69 kV overhead transmission lines owned by East River to 115 kV transmission lines.
- Converting seven existing 69/12.47 kV electrical distribution substations owned by East River to 115/12.47 kV distribution substations.
- Replacing 36 miles of existing shield wire used to protect the transmission lines from lightning with a shield wire containing a fiber optic wire to be utilized by East River for the purpose of communicating with electronic devices East River utilizes in its electric transmission control system.
- Adding a 230/115 kV transformer at the East River/Western Area Power Administration Virgil Fodness High Voltage Substation and a new 115 kV bay at the Western Area Power Administration (WAPA) Sioux Falls High Voltage Substation.

The proposed Project will be constructed in six parts:

1. Conversion of the facilities between WAPA's Sioux Falls High Voltage Substation and the Brandon Substation which will upgrade 5.9 miles of transmission line and three substations.
2. Conversion of the facilities from the Brandon Substation to the Rowena Substation which will upgrade 5.1 miles of transmission line and one substation.
3. Conversion of the facilities from the Rowena Substation to the Split Rock Substation which will upgrade 5.7 miles of transmission line and one substation.
4. Conversion of the facilities from the Split Rock Substation to the Harrisburg Substation which will upgrade 8.9 miles of transmission line and two substations.

5. Conversion of the facilities between the Harrisburg Substation and Interstate 29 which will upgrade 7.75 miles of transmission line.

At the Virgil Fodness High Voltage Substation, a new 230/115 kV transformer will be installed and a new 115 kV bay will be installed at WAPA's Sioux Falls High Voltage Substation.

6. Conversion of the facilities between Interstate 29 and the Virgil Fodness High Voltage Substation which will add 2.5 miles of 115 kV transmission line to an existing 69 kV line, creating a 115/69 kV double circuit.

This application meets the requirements set forth in South Dakota Codified Law (SDCL) 49-41B and South Dakota Administrative Rule (SDAR) 20:10:22. The balance of this document includes the application, supporting exhibits, and supporting documents. In accordance with SDCL 49-41B-22, East River establishes that:

1. The proposed facilities comply with all applicable laws and rules;
2. The facilities will not pose a threat of serious injury to the environment nor to the social and economic condition of inhabitants or expected inhabitants in the siting area;
3. The facilities will not substantially impair the health, safety or welfare of the inhabitants; and
4. The facilities will not unduly interfere with the orderly development of the region with due consideration having been given the views of governing bodies of affected local units of government.

East River requests the Public Utilities Commission (PUC) of South Dakota to make complete findings and render a decision to grant a permit to both upgrade and construct the transmission facilities upon such terms, conditions or modification of the construction, and operation or maintenance as the Commission may deem appropriate.

East River Electric Power Cooperative, Inc.

By: 
Jim Edwards, P.E.

Title: Assistant General Manager-Operations

Date: February 23, 2004

2.0 APPLICATION

This East River PUC application was developed and organized to meet the requirements of the South Dakota PUC rules set forth in SDAR 20:10:22. This application is submitted to the South Dakota PUC and conforms to South Dakota statutes and rules governing energy conversion and transmission facilities.

2.1 NAME OF PARTICIPANTS (SDAR 20:10:22:06)

The applicant's name, address, and telephone number is:

East River Electric Power Cooperative, Inc.
121 SE 1st Street
P.O. Box 227
Madison, SD 57042
(605) 256-4536

The individuals authorized to receive communications relating to the application on the behalf of East River are:

David L. Blair
General Counsel
East River Electric Power Cooperative, Inc.
121 SE 1st Street
P.O. Box 227
Madison, SD 57042
(605) 256-4536
dblair@eastriver.coop

Jim Edwards
Assistant General Manager-Operations
East River Electric Power Cooperative, Inc.
121 SE 1st Street
P.O. Box 227
Madison, SD 57042
(605) 256-4536
jedwards@eastriver.coop

Dan Wall
Manager, Transmission/Engineering Services
East River Electric Power Cooperative, Inc.
121 SE 1st Street
P.O. Box 227
Madison, SD 57042
(605) 256-4536
dwall@eastriver.coop

2.2 NAME OF OWNER AND MANAGER (SDAR 20:10:22:07)

The proposed transmission facilities are owned by East River. The Project Manager for the Project is:

Jim Edwards
Assistant General Manager-Operations
East River Electric Power Cooperative, Inc.
121 SE 1st Street
P.O. Box 227
Madison, SD 57042
(605) 256-4536
jedwards@eastriver.coop

2.3 DESCRIPTION OF THE NATURE AND LOCATION OF THE TRANSMISSION PROJECT (SDCL 49-41B-11 (2))

East River is proposing to upgrade its existing 69 kV overhead electric transmission system located northeast, east and south of Sioux Falls, South Dakota to 115 kV. (Exhibit 1). The entire Project is referred to in this application as the "Sioux Falls Area 115 kV Transmission Upgrade Project" or as the "Project".

The Project will provide for increased voltage and capacity levels necessary to reliably meet the increasing electric cooperatives' electrical demand in the Sioux Falls area.

The Sioux Falls Area 115 kV Transmission Upgrade Project will include:

- Converting approximately 36 miles of existing 69 kV overhead transmission lines owned by East River to 115 kV transmission lines.
- Converting seven existing 69/12.47 kV electrical distribution substations owned by East River to 115 kV distribution substations.
- Replacing 36 miles of existing shield wire used to protect the transmission lines from lightning with a shield wire containing a fiber optic wire to be utilized for communicating with electronic devices East River utilizes in its electric transmission control system.
- Addition of a 115 kV power supply bay to the existing WAPA Sioux Falls Substation and addition of a 230/115 kV transformation and

bay to the jointly owned East River/WAPA Virgil Fodness High Voltage Substation. (Exhibit 2)

The proposed multi-year Sioux Falls Area 115 kV Transmission Upgrade Project will be completed in six parts. (Exhibit 3)

Part One Upgrade East River's existing transmission system between WAPA's Sioux Falls Substation and East River's Brandon Substation. This part will upgrade 5.9 miles of transmission line and three substations to 115 kV. (Exhibits 4, 4a and 4b)

Part Two Upgrade East River's existing transmission system between the Brandon Substation and East River's Rowena Substation. This part will upgrade 5.1 miles of transmission line and one substation to 115 kV. (Exhibits 5, 5a and 5b)

Part Three Upgrade East River's existing transmission system between the Rowena Substation and East River's Split Rock Substation. This part will upgrade 5.7 miles of transmission line and one substation to 115 kV. (Exhibits 6, 6a and 6b)

Part Four Upgrade East River's existing transmission system between the Split Rock Substation and East River's Harrisburg Substation. This part will upgrade 8.9 miles of transmission line and two substations to 115 kV. (Exhibits 7, 7a and 7b)

Part Five Upgrade East River's existing transmission system between the Harrisburg Substation and Interstate 29. This part will upgrade 7.8 miles of transmission line to 115 kV. (Exhibits 8, 8a and 8b)

Part Five will also involve adding a 230/115 kV transformer at the Virgil Fodness Substation and a new 115 kV bay at WAPA's Sioux Falls Substation. (Exhibit 2)

Part Six Rebuilt East River's existing 2.5 mile 69 kV transmission line between Interstate 29 and the Virgil Fodness Substation. This part will create a 2.5 mile 115/69 kV double line. (Exhibits 9, 9a and 9b)

The existing transmission line is located in both rural croplands (Exhibit 10) and urban growth areas. (Exhibit 11) The 36 miles of transmission line involved in the Project will require no new right-of-way (ROW). As well, the seven substations being upgraded will not require additional land.

East River does not anticipate any deviations from the existing transmission line routes.

2.4 PURPOSE OF FACILITY (SDAR 20:10:22:08)

East River is a consumer-owned, regional power supply cooperative headquartered in Madison, South Dakota. It transmits wholesale electricity to 22 member electric distribution systems in Minnesota and South Dakota. These member systems, in turn, distribute electricity to approximately 83,000 consumers.

Two of East River's member systems, Sioux Valley Energy headquartered in Colman, South Dakota and Southeastern Electric Cooperative headquartered in Marion, South Dakota serve a substantial and growing electric load in the area around Sioux Falls. Presently, East River transmits power to Sioux Valley Energy and Southeastern Electric Cooperative in the Sioux Falls area through a 69 kV transmission system owned by East River. This system, consisting of overhead power lines and distribution substations, has been serving member consumers in the Sioux Falls area for the past half century.

Engineering studies and load growth projections completed by East River, Sioux Valley Energy, and Southeastern Electric Cooperative show the two distribution cooperatives' electricity demand and energy usage in the Sioux Falls area increasing by approximately 5% per year.

Presently, East River's 69 kV transmission system on the east side of Sioux Falls has a peak loading of approximately 22 MWs. This is expected to increase to around 31 MWs by 2010 and 40 MWs by 2015. East River's transmission system on the west side of Sioux Falls presently has a peak loading of around 31 MWs which is expected to increase to 51 MWs by 2010 and 62 MWs by 2015.

Engineering studies performed by East River indicate East River's existing 69 kV system on the east side of Sioux Falls is inadequate to meet this growing electrical need around Sioux Falls. In order to serve this increasing load reliably and efficiently, East River is proposing to upgrade its 69 kV system on the east side of Sioux Falls to 115 kV. This system runs from WAPA's Sioux Falls Substation on the northeast side of Sioux Falls and extends around the east and south sides of Sioux Falls to the new Virgil Fodness Substation, located two miles south of Tea, South Dakota. East River's 69 kV system on the west side of Sioux Falls will require some upgrades to serve the increased electrical demand, but conversion of the west side system to 115 kV is not required at this time.

2.5 ESTIMATED COST OF FACILITY (SDAR 20:10:22:09)

The estimated total cost of this Project is \$6,908,000. The cost per breakdown by Project Part is as follows:

| | |
|------------|-------------|
| Part One | \$1,560,000 |
| Part Two | \$ 404,000 |
| Part Three | \$ 455,000 |
| Part Four | \$1,086,000 |
| Part Five | \$3,011,000 |
| Part Six | \$ 392,000 |

East River will utilize its existing work force to complete this Project. Cost estimates for the Project are based on East River's construction cost histories accumulated during recent construction projects.

2.6 DEMAND FOR FACILITY (SDAR 20:10:22:10)

The historic and projected summer and winter peak electrical demand for the Cooperative's load on the east side of Sioux Falls is given in the table below. The load growth projections are based on:

- The Cooperative's 2003 Power Requirements Study and 2000 Engineering Requirements Study.
- An analysis of the load growth in this area for the last ten years.
- Review of the various Sioux Falls area development plans.
- Survey of load growth experienced by other cooperatives serving similar types of areas around growing cities.

| Year | Summer Peak (kW) | Winter Peak (kW) |
|------|---------------------|---------------------|
| 1994 | 13,538 | 16,761 |
| 2000 | 21,114 | 16,655 |
| 2002 | 24,204 | 21,187 |
| 2003 | 21,820 | 17,491 |
| 2010 | 35,820 | 23,661 |
| 2015 | 44,430 | 30,198 |

This Project will allow East River to reliably and efficiently serve the current and projected load growth of Sioux Valley Energy and Southeastern Electric Cooperative in the Sioux Falls area. It will also strengthen and reinforce the rest of East River's transmission system in the Sioux Falls and surrounding area providing increased reliability and capacity to the cooperatives.

If the 115 kV upgrade Project is not done or is delayed significantly beyond the projected completion date and the load grows as projected, the East River transmission system in the Sioux Falls area will have increasing operational, reliability, and system loading problems. As system loading increases, serving

the load reliably and preventing thermal overloading during system contingencies will become more difficult.

2.7 GENERAL SITE DESCRIPTION (SDAR 20:10:22:11)

As stated in Section 2.3, the Sioux Falls Area 115 kV Transmission Upgrade Project is proposed to be completed in six parts. A general description of these six parts is in this section.

2.7.1 PART ONE (Exhibits 4, 4a and 4b)

The existing transmission line involved in Part One of the Project was originally constructed in 1963. It originates at WAPA's Sioux Falls Substation (Exhibit 12) located at 4400 North Timberline Avenue and extends east paralleling the north side of Rice Street to a location one-quarter mile west of East River's West Brandon Substation.

At that point, the West Brandon Substation line tap, originally constructed in 1987, connects to the main transmission line. The substation line tap crosses Brandon Road (also known as Rice Street) to the south side and turns east where it continues to parallel the road to the West Brandon Substation.

The main transmission line, from the point where the West Brandon Substation line tap connects to it, turns north until 261st Street (also known as Redwood Boulevard) where the line route turns east and runs on the south side of 261st Street to a point approximately one-half mile west of East River's Brandon Substation.

At that point, East River's Corson Substation line tap, originally constructed in 2002, connects to the main transmission line. The Corson Substation line tap crosses 261st Street to the north and continues north approximately one-half mile, crossing Interstate 90. After crossing Interstate 90, the Corson Substation line tap runs west for one-quarter mile and then turns north where it continues for one-half mile to the Corson Substation.

The main transmission line, from the point where the Corson Substation line tap connects to it, continues to the east for one-quarter mile where it connects to the Brandon Substation.

Due to both the age of the transmission system and the weight of the larger conductor required to transmit the higher loads, the majority of the structures in Part One will be removed and replaced with new structures. In some locations, structures may need to be relocated within the existing ROW. The existing single pole structures with wooden wishbone crossarms (Exhibit 13) will be replaced with single pole structures (Exhibits 14 and 14a). The two pole structures (Exhibit 15) will continue to use a wooden crossarm for this purpose. The 3/8

steel shield wire attached at the top of the poles will be replaced with a shield wire containing an embedded fiber optic wire. This fiber optic wire will be utilized by East River for the purpose of communicating with electronic relaying, control, and communication devices East River utilizes in its electric transmission control system. Several line switches will be replaced with 115 kV switches to handle the higher voltage level as well.

East River's West Brandon and Brandon Substations will be upgraded to accommodate the higher voltage level. This upgrade consists of replacing the transformer, switches and insulators and other equipment to 115 kV rated equipment.

In 2002, the Corson Substation and its associated line tap were constructed. Although operated today at 69 kV, both the substation and line were constructed so that they could be operated in the future at 115 kV. Because of this, no upgrades will be made to the Corson Substation and its line tap in this Project.

2.7.2 PART TWO (Exhibits 5, 5a and 5b)

The existing transmission line involved in Part Two was originally constructed in 1975. It originates at East River's Brandon Substation and extends east, crossing Split Rock Boulevard, paralleling the north side of 261st Street (Chestnut Avenue) to 483rd Avenue where it turns south, paralleling 483rd Avenue on the east side. The transmission line crosses 262nd Street following the section line until it crosses 263rd Street. At this point, the line continues south, paralleling 483rd Avenue on the east for two miles to the point it enters East River's Rowena Substation property.

The transmission system in Part Two consists of both single pole wooden structures as well as two pole wooden structures. The existing poles, crossarms and conductors in this line section will not need to be replaced for the conversion except for the possible replacement of any defective structures or components. An additional insulator will be added to each string of insulators to increase the insulation rating of the line from 69 kV to 115 kV. The shield wire will be replaced with a shield wire containing a fiber optic wire to be utilized by East River for the purpose of communicating with electronic devices East River employs in its electric transmission control system. One line switch will be replaced with a 115 kV switch to handle the higher voltage level.

East River's Rowena Substation will have its transformer, switches, insulators and other equipment replaced with 115 kV rated equipment.

2.7.3 PART THREE (Exhibits 6, 6a and 6b)

The existing transmission line involved in Part Three was originally constructed in 1978. It originates at East River's Rowena Substation and extends south, following 483rd Avenue one mile to 266th Street. There the line turns west, paralleling 266th Street on the south side for one mile. At that point the line crosses back to the north side of 266th Street continuing west for one mile. After crossing to the west side of 481st Avenue, the transmission line crosses to the south of 266th Street (Iverson Crossing Road) and continues west for one-half mile, then crosses back to the north side of 266th Street. The line continues on to the west for one and one-half miles, crossing Highway 42 to where there is a three way line switch (Exhibit 16) at the intersection of 266th Street and Six Mile Road. The line being upgraded in Part Three continues north from the line switch, paralleling Six Mile Road on the east side for approximately one mile, again crossing Highway 42, until it connects to East River's Split Rock Substation.

The existing poles, crossarms and conductors in this line section will not need to be replaced for the conversion except for the possible replacement of any defective structures or components. An additional insulator will be added to each string of insulators to increase the insulation rating of the line from 69 kV to 115 kV. The shield wire will be replaced with a shield wire containing a fiber optic wire to be utilized by East River for communicating with electronic devices East River utilizes in its electric transmission control system. One line switch will be replaced with a new 115 kV switch to handle the higher voltage level.

East River's Split Rock Substation will have its transformer, switches, insulators and other equipment replaced with 115 kV rated equipment.

2.7.4 PART FOUR (Exhibits 7, 7a and 7b)

The transmission line in Part Four was originally constructed in 1979. It originates at the line switch on the corner of 266th Street and Six Mile Road. From this point, the transmission line runs south for two miles paralleling Six Mile Road on the east side. The line crosses Six Mile Road to the west and continues west for one-half mile, paralleling 268th Street on the south side. The transmission line turns south at the quarter line and runs south for one-half mile, crossing 269th Street and then connects to East River's Shindler Substation. The Shindler Substation and its associated line tap were constructed in 2000.

East River's transmission line continues to the south from the Shindler Substation to East River's Harrisburg Substation. This portion of the line is built on the quarter line for two miles until it crosses to the south side of 271st Street. There the line turns west and proceeds west for one half-mile crossing to the west side of Highway 11. The line turns south continuing for three miles until it crosses to the south side of 274th Street. The line turns west and proceeds west

for approximately one-quarter mile where it connects with East River's Harrisburg Substation.

The existing poles, crossarms and conductors in this line section will not need to be replaced for the conversion except for the possible replacement of some defective structures or components. An additional insulator will be added to each string of insulators to increase the insulation rating of the line from 69 kV to 115 kV. The shield wire will be replaced with a shield wire containing a fiber optic wire to be utilized by East River for communicating with electronic devices East River utilizes in its electric transmission control system. Several line switches will be replaced with 115 kV switches to handle the higher voltage level.

East River's Harrisburg and Shindler Substations will have their transformers, switches, insulators and other equipment replaced with 115 kV rated equipment.

2.7.5 PART FIVE (Exhibits 8, 8a and 8b)

The transmission line in Part Five was originally constructed in 1953 and upgraded in 1979. It originates at East River's Harrisburg Substation proceeding west on the south side of 274th Street for two and three-quarter miles. At that point the transmission line crosses to the north side of 274th Street continuing west for one and three-quarter miles. There the line turns south following the quarter line south for one-half mile. The line turns west again and follows the quarter line west for three miles to that point where the line crosses to the west side of Interstate 29 and connects to an existing East River line switch.

The first two and three-quarter miles of transmission line going west out of the Harrisburg Substation will be rebuilt with new conductor and poles. The remaining five miles will not have its poles and conductor replaced, but an additional insulator will be added within the insulator string. The shield wire will be replaced with a shield wire containing a fiber optic wire to be utilized by East River for communicating with electronic devices East River utilizes in its electric transmission control system. One line switch will be replaced with a 115 kV switch to handle the higher voltage level.

2.7.6 PART SIX (Exhibits 9, 9a and 9b)

The existing transmission line in Part Six was originally constructed in 1975 and 1978. It begins with the line switch located on the west side of Interstate 29 and proceeds west on the quarter line for one mile. There the line turns north following the quarter line until the line crosses to the north side of 274th Street. The line then turns west and proceeds west for one mile where it turns north into the Virgil Fodness High Voltage Substation.

For this part, the existing 69 kV line will be rebuilt to a double circuit 115/69 kV line (Exhibit 17). The double circuit is needed to maintain East River's 69 kV

system that extends south towards Beresford. The double circuit line will require the existing poles be removed and replaced with taller and larger wooden poles. The crossarms now used to support the 69 kV conductors will be removed and replaced with side mount insulators to support both the 69 kV and 115 kV transmission lines. The shield wire will be replaced with a shield wire containing a fiber optic wire to be utilized by East River for communicating with electronic devices East River utilizes in its electric transmission control system.

Also at the Virgil Fodness High Voltage Substation, a new 230/115 kV transformer and 115 kV bay will be installed and a new 115 kV bay will be installed at WAPA's Sioux Falls High Voltage Substation.

2.8 PROJECT ALTERNATIVES (SDAR 20:10:22:12)

Modeling of the existing East River transmission system around Sioux Falls, using the Cooperative's projected load growth, showed a need to increase capacity in the system in order to maintain adequate voltage levels, system reliability and continuity of service. Several approaches to upgrading the capacity in the system were considered.

1. Leave the system at its current 69 kV voltage level and increase capacity by reconductoring/rebuilding portions of the system and adding additional 69 kV tie lines and a high voltage interconnection.
2. Convert the system to a higher voltage level (115 kV) to increase the overall capacity of the system and, where needed, reconductor sections of lines which have smaller conductors and thermal loading limitations.
3. A combination of the two approaches above.

When considering the different approaches, the following general criteria were used:

- The upgraded system needed to be able to carry the existing and projected Cooperative load during normal and emergency conditions with no reliability or overloading problems.
- The upgraded system needed to maintain the multiple tie lines and high voltage sources required to allow loads to be transferred between line sections and sources during outages, emergencies, and construction/maintenance work.
- Utilizing as much of the existing lines, facilities, equipment and right-of-way as possible.

- Minimize the new lines and facilities required.

The first approach of leaving the system around Sioux Falls at the current 69 kV voltage level was not practical due to the number of additional lines, new sources and the density of distribution substations required to serve the projected load during normal and emergency conditions.

The second approach of converting the entire system around Sioux Falls to 115 kV was not practical due to the amount of the system that would need to be converted to maintain the necessary backup tie lines and sources. Ties between 69 kV and 115 kV systems would require 69 kV to 115 kV transformations at each tie point.

The third approach involved converting sections of the existing system to 115 kV and leaving the remainder of the system at 69 kV. What parts of the system would be converted to 115 kV and what parts would remain at 69 kV would be based on load growth projections, the rating and condition of the various line sections, and the location of tie lines and sources for each particular area. Load growth projections also indicated the timing of when conversions and upgrades needed to be done.

Engineering studies showed that the best approach for upgrading East River's transmission system around Sioux Falls was to convert the portion of the system on the east side between WAPA's Sioux Falls Substation and the Virgil Fodness Substation to 115 kV and leave the rest of the system at 69 kV for now. The system between Sioux Falls and the Virgil Fodness Substation has two sources (Sioux Falls and Virgil Fodness Substation) and no other tie points. Conversion of this section would not require complete rebuild of the line or require additional new lines or right-of-way. The remainder of the system can remain at 69 kV with some additions and upgrades as required. As load grows, additional portions of the system may also need to be upgraded to 115 kV in the future.

As part of its engineering analysis, East River did not consider any alternative transmission line routes for the Project due to the utilization of existing transmission lines and right-of-way.

2.9 ENVIRONMENTAL INFORMATION (SDAR 20:10:22:13)

The proposed Sioux Falls Area 115 kV Transmission Upgrade Project will have minimal environmental impact both during and after construction. The Project utilizes existing transmission lines and ROW. The Project will only minimally alter the appearance, type and location of the approximately 36 miles of existing East River transmission line involved in the Project. Twenty-six miles of the Project will involve adding some insulators, replacing line switches and the static wire, and the possible minor relocation of some poles and guys within the existing ROW. The remaining ten miles of the Project will involve the

replacement of the existing structures, conductors and switches with similar but larger structures and conductors. Also, some equipment will need to be replaced or added at six existing East River distribution substations and at the existing Sioux Falls and Virgil Fodness High Voltage Substations.

Because the Project utilizes existing transmission lines and ROW, the Project should not alter the existing environment of the land around the transmission lines and substations. It also should not cause any increased hazards to the health and welfare of human, plant, and animal communities around the lines.

The existing transmission facilities involved in the Project were built to the United States Department of Agriculture's Rural Utilities Service (RUS) Standards or Approvals. Facilities constructed in 1979 or later required RUS approved Borrowers Environmental Reports before the lines could be constructed. Below are the original construction dates for the different facilities in the Project:

| Part One | |
|--|---------------------|
| Brandon Line Tap | Constructed in 1963 |
| West Brandon Substation and Line Tap RUS Borrowers Environmental Report approved September 1987 | Constructed in 1987 |
| Corson Substation and Line Tap RUS Borrowers Environmental Report approved in 2002 | Constructed in 2002 |
| Brandon Substation and Line Tap | Constructed in 1963 |

| Part Two | |
|--------------------------------|---------------------|
| Brandon to Rowena Line | Constructed in 1975 |
| Rowena Substation and Line Tap | Constructed in 1975 |

| Part Three | |
|------------------------------------|---------------------|
| Rowena to Split Rock Line | Constructed in 1978 |
| Split Rock Substation and Line Tap | Constructed in 1978 |

| Part Four | |
|---|---------------------|
| Split Rock to Harrisburg Line RUS Borrowers Environmental Report approved September 20, 1979 | Constructed in 1979 |
| Shindler Substation and Line Tap RUS Borrowers Environmental Report approved June 1998 | Constructed in 1998 |

| | |
|--|---------------------|
| Harrisburg Substation and Line Tap RUS Borrowers Environmental Report approved September 20, 1979 | Constructed in 1979 |
|--|---------------------|

| Part Five | |
|-----------------------------|----------------------|
| Harrisburg to Interstate 29 | Construction in 1953 |

| Part Six | |
|--------------------------------|---------------------|
| Interstate 29 to Tea Line | Constructed in 1975 |
| Tea to Virgil Fodness Line Tap | Constructed in 1978 |

2.10 EFFECT ON PHYSICAL ENVIRONMENT (SDAR 20:10:22:14)

This section provides information on the effect of the proposed transmission line facility on the physical environment.

2.10.1 Regional Land Forms

The Project lies in the southern portion of the James River Lowland ecoregion and the northern portion of the Loess Prairies ecoregion. This ecoregion is characterized by mexid soils, warmer temperatures, and a longer growing season than the Drift Plains ecoregion to the north. These differences are reflected in the crop types of the regions. Winter wheat, corn, and soybeans are more prevalent in this ecoregion's climate.

The Loess Prairies ecoregion surrounds the perimeter of the Des Moines lobe of the late Wisconsinan glaciation. The area of the ecoregion the proposed Project is located in is distinguished from neighboring regions by its rock-free soil and a paucity of wetlands.

The Project will not involve any new roads, grading, filling, or other changes to the topography or regional landforms.

2.10.2 Topography

Regional topography is generally characterized by rolling hills and plains. Topographic maps of the different parts the Project are provided in the following Exhibits:

- Exhibit 4b (Part 1)
- Exhibit 5b (Part 2)
- Exhibit 6b (Part 3)
- Exhibit 7b (Part 4)
- Exhibit 8b (Part 5)
- Exhibit 9b (Part 6)

2.10.3 Geologic Features

The proposed Project is located in two ecoregions, the James River Lowland comprised of glacial till over cretaceous pierre shale and sandstone of Niobrara Formation and the Loess Prairies comprised of loess deposits over cretaceous sandstone, shale (Niobrara Formation and Carlile Shale), and Sioux Quartzite.

2.10.4 Economic Deposits

The most important mineral resources in the region are sand and gravel excavated from river alluvium and glacial drift. Sioux Quartzite is currently being mined as a gravel source for building materials in Sioux Falls, and is also being explored for uranium. No mining for uranium has occurred. There are no commercially important sources of coal, oil and gas, or metals in the region.

2.10.5 Soil Type

The soil types in the area of the Project are of mollisols (Argiustolls, Haplustolls, Natrustolls).

2.10.6 Potential for Erosion and Sedimentation

The existing transmission lines and substations that are part of the Project have not caused any erosion or sedimentation problems in the past. It is not anticipated that the upgrade of these lines will cause erosion or sedimentation problems in the future.

2.10.7 Seismic Risks, Subsidence Potential, and Slope Instability

The electric transmission lines and substations involved in the Project were originally designed and constructed to meet utility standards. As a result, no issues relating to seismic risks, subsidence, and slope instability have been identified since their original construction. All changes to the transmission lines and substations will also meet these standards and will comply with all applicable construction codes. Potential difficulties due to seismic activities, subsidence and slope instability will be avoided through proper design and construction.

2.10.8 Geological Constraints

There were no geological constraints identified when the transmission lines and substations were originally constructed and it is not anticipated that any geological constraints will impact the Project.

2.11 HYDROLOGY (SDAR 20:10:22:15)

This section provides information on the hydrology of the Project area and the effect of the proposed Project on surface and groundwater.

2.11.1 Hydrologic Map

The topographic map exhibits 4b, 5b, 6b, 7b, 8b and 9b show the terrain and drainage patterns in the areas around the transmission upgrade project. As this Project is an upgrade to existing transmission facilities and does not involve any new roads, grading, filling, deforestation, or significant vegetation removal, there will be no changes to the current drainage patterns.

2.11.2 Effect on Current Planned Water Uses

The proposed transmission upgrades will not use either municipal or private water and therefore, will have no impacts on any planned water uses by communities, agriculture, recreation, fish, or wildlife.

2.11.3 Surface and Groundwater Use by Proposed Facility

The proposed transmission upgrades will not require consumptive use of or discharge to any surface water body or groundwater.

2.11.4 Aquifer Use by Proposed Facility

The proposed transmission upgrades will not require the use of groundwater as a source of potable water supply or process water.

2.11.5 Water Storage, Reprocessing, and Cooling by Proposed Facility

No water storage, reprocessing, or cooling will be required for the construction or operation of the proposed transmission facilities.

2.11.6 Deep Well Injection Use by Proposed Facility

No deep well injection would be required for the construction or operation of the proposed transmission upgrades.

2.12 EFFECT ON TERRESTRIAL ECOSYSTEMS (SDAR 20:10:22:16)

The proposed Project is an upgrade of existing electric lines currently in place and should have no adverse long term impact on the vegetation and wildlife composition within the Project area. No permanent service road will be required that would result in vegetation removal and unauthorized access. Vegetation removal or habitat loss resulting from pole and anchor placement is insignificant.

The transmission project will not displace or adversely affect wildlife or aquatic species. The Project will not impact ecologically unique or sensitive habitats including wetlands and aquatic habitats.

2.12.1 Effect on Wildlife

The proposed Project should have minimal impact and disruption of any wildlife within the Project area. It should also only cause an insignificant, if any, change or loss of any wildlife habitat or vegetation in the area.

The area around the Project is dominated by agricultural land and some urban developments. The transmission lines involved in the Project are located on road/public right-of-ways, cropland, pastures, urban areas, and some undeveloped areas. Wildlife in this area is made up of species adapted to agricultural and urban areas such as deer, rabbits, raccoons, geese, ducks songbirds and others.

The Project does not involve any new roads, grading, or deforestation. Vegetation clearing will be restricted to areas immediately around the poles. As a result, the Project should not impact wildlife composition, abundance, or habitat.

Since the Project involves the upgrade of existing transmission lines, instead of construction of new lines, the Project should not cause increased bird mortality due to electrocution or collision with the wire.

2.12.2 Effect on Vegetation

The impact to vegetation in the Project area should be minimal. As stated in 2.12.1, the transmission lines are located on road/public right-of-ways, croplands, pastures, urban areas, and some undeveloped areas. The Project does not include any new roads, buildings, grading, water uses, or other changes to the land that may have a long term negative impact to vegetation. Also, the Project should not cause any future erosion problems which could impact vegetation.

Construction of the Project will have a short term impact on vegetation as a result of vehicle and equipment accessing the structures, material delivery, structure assembly and erection, and stringing of conductors and static wire. Also, there will be some minor vegetation removal around the poles.

2.13 EFFECT ON AQUATIC ECOSYSTEMS (SDAR 20:10:22:17)

The proposed Project should not adversely impact any aquatic ecosystems. The Project does not directly change or impact any wetlands, streams, or rivers. Also, the Project does not require any new roads, grading filling, or other

changes to the existing terrain that could cause erosion or sedimentation problems or would change any existing drainage patterns.

The Project does involve the replacement of conductors and static wire across existing crossings of a river and creeks and some replacement of the poles near these crossings. These include:

- Part One: Big Sioux River
- Part Two: Split Rock Creek
- Part Three: Big Sioux River
- Part Four: Spring Creek
- Part Five: Nine Mile Creek

At these crossings and when working near any wetlands, streams, rivers, aquatic ecosystems and drainage areas, East River will utilize construction practices to minimize any impact to them and the land and vegetation adjacent to them. As listed in Section 2.16, East River will comply with all applicable federal, state and local rules and regulations and will follow the specific measures listed in Section 2.16 to protect wetlands, streams and rivers.

2.14 LAND USE (SDAR 20:10:22:18)

This section provides information concerning the present and anticipated use or condition of the land in the area of the Project.

2.14.1 Land Use Map

Minnehaha and Lincoln County Land Use Maps (Exhibits 19 and 20) depict land use within the proposed Project corridor. The proposed Project crosses a diverse landscape with a mixture of land uses.

2.14.2 Homes and Persons Displaced

There will be no homes or persons displaced as a result of the construction, operation, or maintenance of the transmission facilities that are part of this Project.

2.14.3 Land Use Compatibility

This Project will not change the compatibility and relationship of the transmission lines and substations with the surrounding areas.

2.14.4 Effect on Land Use

The land in the right-of-way can be used for the same purpose as prior to this Project. The land will still be subject to the restrictions that exist with the current

easements and have been in effect since the lines were originally constructed. These restrictions include that trees and structures that might interfere with the safety, operation or maintenance of the line may not be permitted in the right-of-way.

2.15 LOCAL LAND USE CONTROLS (SDAR 20:10:22:19)

The proposed Project will comply with all applicable zoning requirements. No existing land use controls by any of the governing bodies (Minnehaha County, the City of Brandon, Lincoln County) restrict the use of the land within the proposed Project area for the purpose of constructing and maintaining the transmission facility.

2.16 WATER QUALITY (SDAR 20:10:22:20)

This Project should not impact any wetlands, streams or rivers. The project will comply with all applicable federal, state and local rules and regulations required for alteration of wetlands, streams, or rivers resulting from the Project. The following are specific measures that would be taken to protect water quality in the proposed Project corridor:

- Best management practices would be implemented to minimize erosion and sedimentation, runoff, and surface instability during construction.
- Construction would be conducted to minimize disturbances around surface water bodies to the extent possible.
- Current drainage patterns in areas affected by construction will be maintained.
- Staging areas for project-related construction equipment would be located in areas that are not environmentally sensitive to control erosion.
- Staging and laydown yards for project-related construction would be established at least 59 feet from waterways or wetlands, if permitted by topography. No vegetation would be cleared between the yard and the waterway or wetland.
- Construction equipment would not be serviced within 25 feet of waterways or wetlands. Equipment would not be fueled within 100 feet of the waterways or wetlands.

- Any spills of fuels or other hazardous materials during construction or system maintenance would be promptly contained and cleaned up.
- Any herbicides used in right-of-way maintenance would be approved by U.S. Environmental Protection Agency and applied by licensed professions. Application of herbicides would be limited to the extent necessary for regular maintenance of the transmission system.

2.17 AIR QUALITY (SDAR 20:10:22:21)

No significant or long-term impacts to air quality will occur as a result of this Project. Construction traffic may generate some local dust for short duration. However, the number of vehicles involved in this Project is low compared to existing background traffic levels and will be short term (several days) at each part of the Project. The Project will comply with all federal, state and local air quality standards and regulations.

2.18 TIME SCHEDULE (SDAR 20:10:22:22)

The current estimated time schedule for the Project is below:

- Part One 1 completed in 2004
- Part Two completed in 2005
- Part Three completed in 2006
- Part Four completed in 2007
- Part Five completed in 2008
- Part Six completed in 2004

2.19 COMMUNITY IMPACT (SDAR 20:10:22:23)

This section reviews the effects the construction, operation, and maintenance of the Project will have on socioeconomic, taxation, agricultural production, population and community, transportation, and cultural resources.

2.19.1 Forecast of Socioeconomic Impact

No significant socioeconomic impacts to the local communities and governmental facilities or services are anticipated as a result of this Project. Following completion, the Project will not result in secondary socioeconomic impacts.

The Project will result in increased reliability of electrical service to the Cooperative's consumers in the area and provide additional power transmission capacity for a rapidly expanding area of the state, thus providing a social and economic benefit to the area.

2.19.2 Property and Other Tax Impacts

No significant immediate or long-term impact on property and other taxes of the affected taxing jurisdictions are anticipated as a result of the Project. No corresponding loss of property taxes is expected since the Project is an upgrade of an existing electric line that occupies private and public right-of-way.

2.19.3 Forecast of Agricultural Impacts

The electric lines involved in the Project were originally sited along right-of-way and property lines. As a result, the Project is not expected to interfere with agricultural operations or result in the loss of croplands. Should damage occur to crops during construction of this Project, landowners are reimbursed for damages as a normal part of easement costs.

2.19.4 Forecast of Population and Community Impacts

The proposed transmission Project is not expected to impact the population, income, and occupational distribution on the short-term. However, long-term population increases could result from increased power availability in the area.

2.19.5 Forecast of Transportation Impacts

No significant direct, indirect, or cumulative impacts are expected to the transportation systems of cities, counties, and the state as a result of the Project. Short-term impacts may include minor traffic delays caused when wires are strung across roadways or rail lines. Any such short-term roadway or railway closings would be scheduled with appropriate authorities and marked clearly, and detour routes would be provided as necessary. Construction of the proposed Project would be expected to cause only insignificant and temporary adverse transportation effects to public access as a result of roadway congestion from work vehicles.

2.19.6 Forecast of Cultural Resource Impacts

The Project is an upgrade of existing electric lines and substations. As such, there are no anticipated impacts to cultural resources as a result of the Project. East River is required by Federal regulation to have in place a "Spill Prevention Control and Countermeasure Plan" (SPCC) for all of its substations, which it does. Should an accidental release of contaminants occur, East River will follow applicable Federal, state and local regulations.

2.20 EMPLOYMENT ESTIMATES (SDAR 20:10:22:24)

This Project will utilize existing work force employed by East River supplemented by up to four workers employed for the construction season. No permanent additional employment is expected as a result of the Project.

2.21 FUTURE ADDITIONS AND MODIFICATIONS (SDAR 20:10:22:25)

At this time, East River does not anticipate any future additions or modifications to this Project that would need to be approved under this permit application.

2.22 RIGHT-OF-WAY ACCESS, CLEARING, WEED CONTROL, AND RESTORATION (SDAR 20:10:22:34)

This section includes information on East River Electric's policies concerning route clearing, restoration, revegetation and weed control.

2.22.1 Vegetation Clearing

The proposed Project is located in existing right-of-way with existing easements for trimming vegetation that will endanger the electric system. East River annually trims vegetation away from its lines for this purpose. It is expected that no additional vegetation will be removed for the Project or that any vegetation outside the existing easement areas will be involved in this Project.

2.22.2 Soils

Any soils removed during borings for the transmission line structures would be used for backfill. Any remaining material would be spread and mounded near the base of the transmission line structures. After construction is complete, any compacted soil would be tilled and the area would be reseeded with native grasses.

2.22.3 Herbicides and Sterilants (Weed Control)

It is East River's policy to use mechanical methods to clear the right-of-way. However, where the use of mechanical or hand methods are impractical, the selective use of herbicides may be necessary. In these instances, the appropriate Federal and state agencies will be notified, only approved herbicides will be used, and all recommended precautions will be taken.

2.22.4 Construction Site Access

All line segments are either built in right-of-way with easements that allow access for construction and maintenance purposes, or are built in public right-of-way

along public roads that provide access for construction and maintenance purposes.

2.22.5 Waste Disposal

Vegetation that may be removed from the right-of-way and debris resulting from the upgrade work will be disposed of in a manner approved by local authorities.

2.22.6 Restoration and Revegetation

Those areas requiring revegetation will be reseeded with vegetation recommended by the Soil Conservation Service.

2.23 TRANSMISSION FACILITY DESIGN AND CONSTRUCTION (SDAR 20:10:22:35)

This section includes information on: (1) configuration of poles; (2) line switches, conductor configuration; (3) proposed transmission site and major alternatives; (4) reliability and safety; (5) right-of-way or condemnation requirements; (6) necessary clearing activities; and (7) underground utility details.

2.23.1 Configuration of Poles

Three basic structure types would be used for the transmission line.

1. A single pole wooden structure configured with three side mount insulators supporting the three phase conductors and one suspension shoe mounted at the top of the structure supporting the shield wire. (Exhibits 14 and 14a)
2. A single pole wooden structure configured with wooden cross arms supporting the three phase conductors. One suspension shoe mounted at the top of the structure will support the shield wire. (Exhibits 18 and 18a)
3. A two pole wooden structure configured with a horizontal cross arm. Three insulator strings will be attached to the crossarm for supporting the three phase conductors. A shield wire will be suspended from the top of one of the two poles to support the shield wire. (Exhibits 15 and 15a)
4. Part Six will utilize a single pole wooden structure configured with side mount insulators that will support a double circuit. (Exhibit 17)

2.23.2 Line Switches

Line switch structures will be one of the following two designs:

1. A single pole wooden structure configured with three steel gangs. Each gang supports a line switch. (Exhibits 21 and 21a)
2. A two pole wooden structure supporting a steel line switch. (Exhibits 22 and 22a)

2.23.3 Conductor Configuration

This section includes information on the conductor configuration and size, length of span between structures and number of circuits per pole for the six parts of the Project.

Part One of the Project is a 69 kV single circuit. That portion of Part One which runs from Western's Sioux Falls Substation to East River's Brandon Substation was originally constructed with 4/0 ACSR conductor and designed with 430 foot ruling spans. As proposed, the Project will replace the existing poles, replace the conductor with T-2 Penguin (477 MCM equivalent) using 350 foot ruling spans and replace the 3/8 high strength steel shield wire with 0.57 inch Optical Ground Wire (OPGW).

The portion of Part One, which connects the West Brandon Substation to the main line, was also constructed with 4/0 ACSR conductor using 325 foot ruling spans. The proposed Project will add insulators to this portion of the line; the existing poles and conductor will not be replaced.

The portion of Part One which connects the Corson Substation to the main line was originally constructed with T-2 Raven conductor using 350 foot ruling spans. No change is proposed for this portion.

Part Two of the proposed Project is a 69 kV single circuit line constructed with 4/0 ACSR conductor using 430 foot ruling spans. No change to the conductor is proposed for this Project. The shield wire will be replaced with 0.57 inch OPGW.

Part Three is a 69 kV single circuit line constructed with both 4/0 ACSR and 336 MCM conductor using 430 and 400 foot ruling spans. No change to the conductor is proposed for this Project. The shield wire will be replaced with 0.57 inch OPGW.

Part Four is a 69 kV single circuit line constructed with 336 MCM conductor using 400 foot ruling spans. No change to the conductor is proposed. The shield wire will be replaced with 0.57 inch OPGW.

Part Five is a 69 kV single circuit line constructed with both 4/0 ACSR and 336 MCM conductor using 400 and 430 foot ruling spans. The 2.96 miles of section of line with 4/0 ACSR conductor will be replaced with new poles and T-2 Penguin using a 350 foot ruling span. No change will be made to the conductor and poles on the section of line with 336 MCM conductor except for the addition of an insulator. The shield wire will be replaced with 0.57 inch OPGW.

Part Six is a 69 kV single circuit line constructed with 4/0 ACSR conductor using 430 foot ruling spans. The 2.029 mile portion of this part, located between Interstate 29 and East River's Tea Substation will be rebuilt into a 69/115 kV double circuit. The double circuit will utilize the existing 4/0 ACSR conductor for the 69 kV circuit and will utilize T-2 Penguin conductor for the 115 kV circuit. This double circuit will be built using a 350 foot ruling span.

Included in Part 6 is an additional 0.5 miles segment of 69 kV line located between East River's Tea Substation and East River's Virgil Fodness Substation. This 0.5 mile segment is built with 336.4 MCM conductor using 400 foot ruling spans. This segment will be rebuilt with T-2 Penguin conductor using 350 foot ruling spans. All the shield wires in Part 6 will be replaced with 0.57 inch OPGW.

2.23.4 Proposed Transmission Site and Major Alternatives

The existing transmission line that is proposed to be upgraded in the Project is described in section 2.7. Alternatives are identified in section 2.8.

2.23.5 Reliability and Safety

The proposed transmission line upgrade will be constructed in full compliance with all applicable National Electrical Safety Code electrical performance and safety codes and, as a result, would not present significant impacts posed by safety or electrical hazard to the general public.

2.23.6 Right-of-way or Condemnation Requirements

All easements or permits for the existing transmission line have been previously obtained. No condemnations are anticipated.

2.23.7 Necessary Clearing Activities

East River currently has right-of-way program that includes annual tree trimming. Because of this, no additional clearing activities are anticipated.

2.23.8 Configuration of Underground Facilities

No underground facilities would be required as part of the proposed Project.

2.24 ADDITIONAL INFORMATION IN APPLICATION (SDAR 20:10:22:36)

This application contains all information necessary for the local review committees to assess the effects of the proposed facilities pursuant to SDCL 49-41B-7 and 49-41B-11. This application also contains all information necessary to meet the burden of proof specified in SDCL 49-41B-22.

2.25 TESTIMONY AND EXHIBITS (SDAR 20:10:22:39)



List of Preparers

Ken Booze
Joyce Carman
Jim Edwards
Dean Feistner
Ron Golden
Trish Rotert
Dan Wall
Dan Ziebarth

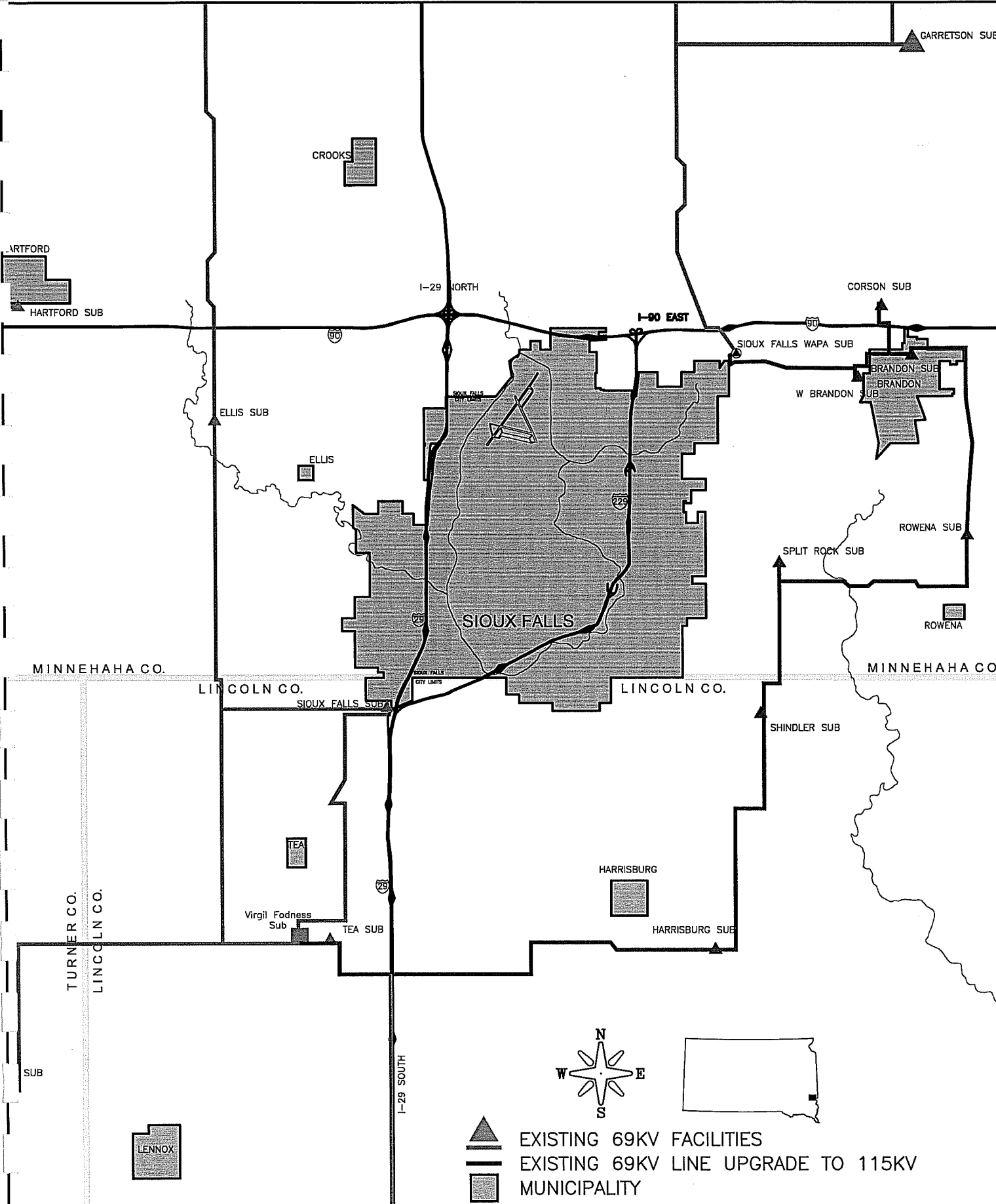
This document is intended to represent the entire application, including all narratives, analysis, and exhibits.

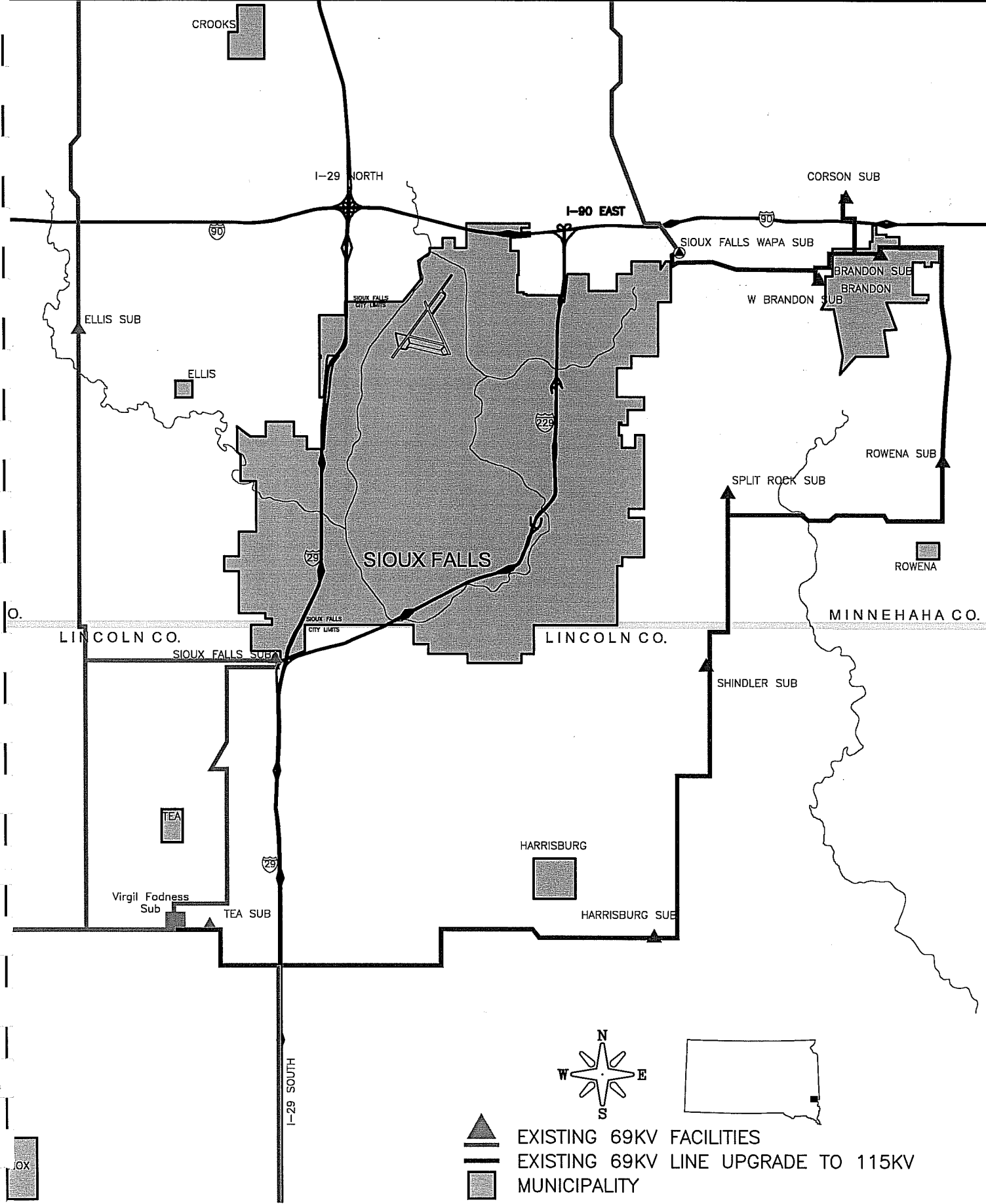



-  EXISTING 69KV FACILITIES
-  EXISTING 69KV LINE UPGRADE TO 115KV
-  MUNICIPALITY







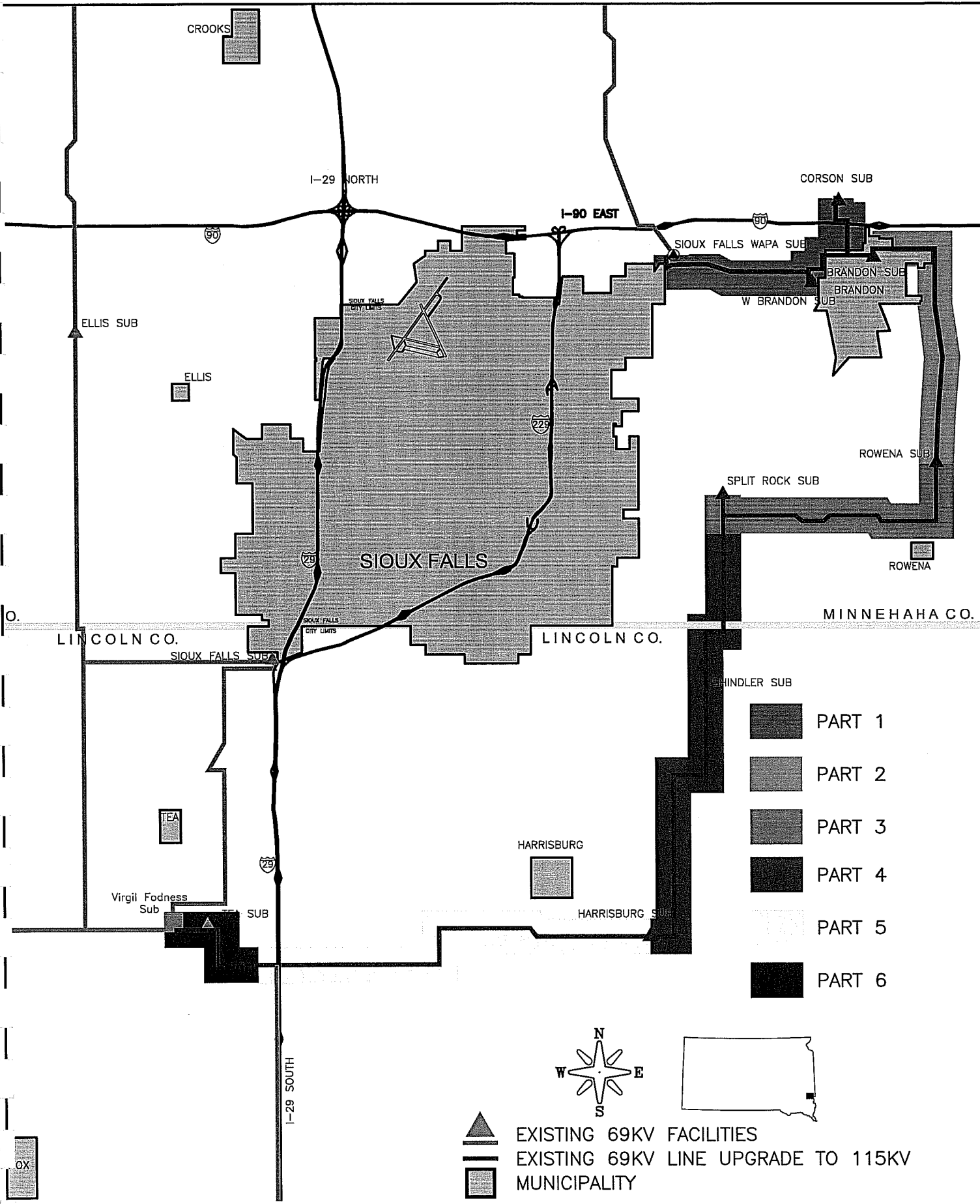

A Touchstone Energy® Cooperative 



DWG. NO.: MAVBSFXBA

Exhibit 2

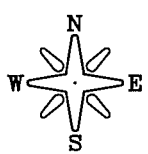

-  PART 1
-  PART 2
-  PART 3
-  PART 4
-  PART 5
-  PART 6



-  EXISTING 69KV FACILITIES
-  EXISTING 69KV LINE UPGRADE TO 115KV
-  MUNICIPALITY





A Touchstone Energy® Cooperative 

DWG. NO.: MAVBSFXBA

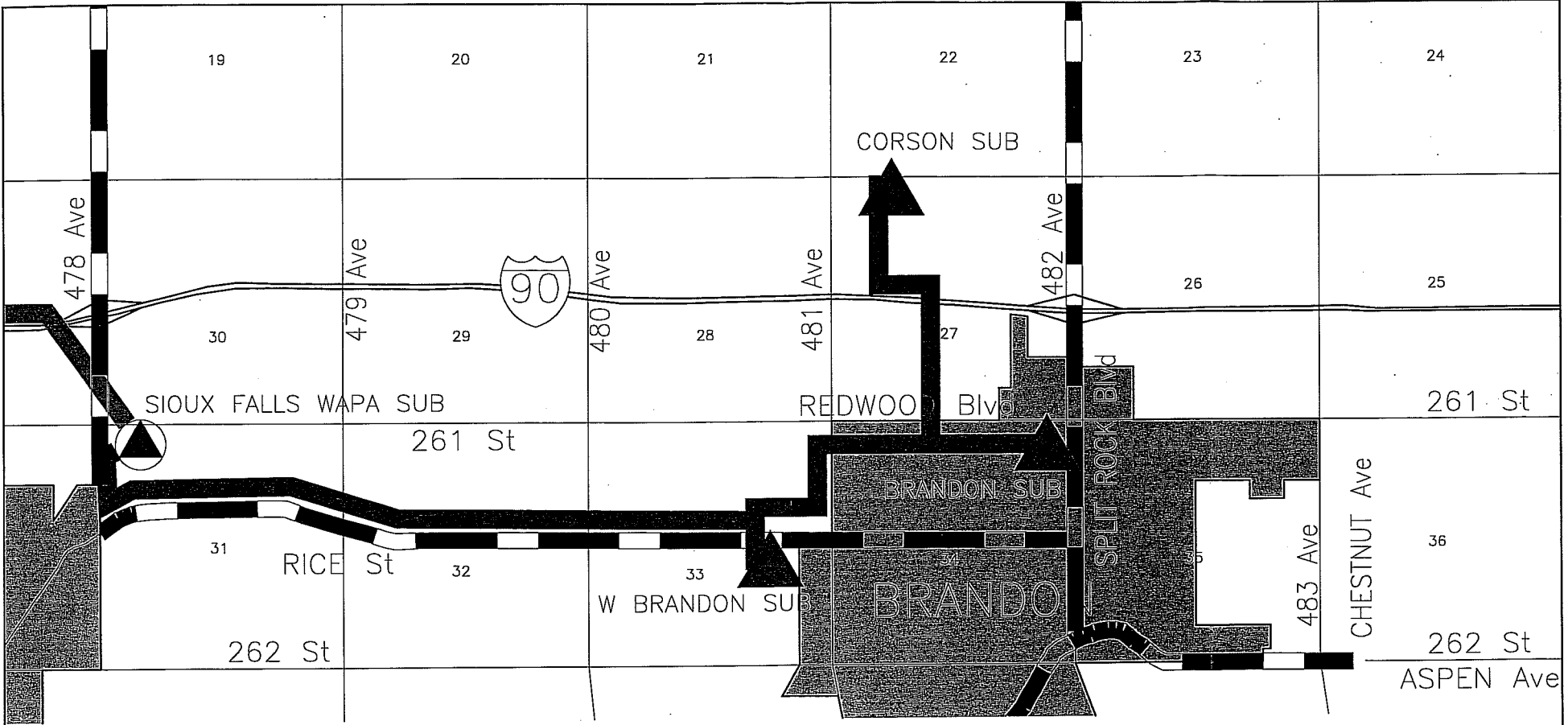
Exhibit 3



-  EXISTING 69KV FACILITIES
-  EXISTING 69KV LINE UPGRADE TO 115KV
-  EXISTING 69KV SUB UPGRADE TO 115KV

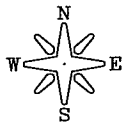

 MUNICIPALITY

| | | |
|--|----------|------------|
| A Touchstone Energy [®] Cooperative  | | |
| PCP FILE: ERTYPLT | | |
| DATE 11-18-03 | W.O. NO. | SCALE NONE |
| MAVRSEYRA | | |



ep. 4
 SIOUX FALLS AREA
 115KV CONVERSION
 PROJECT - PART 1

SIoux FALLS AREA TRANSMISSION UPGRADE
PART 1



Exp. 1

SIoux FALLS AREA TRANSMISSION UPGRADE PART 1

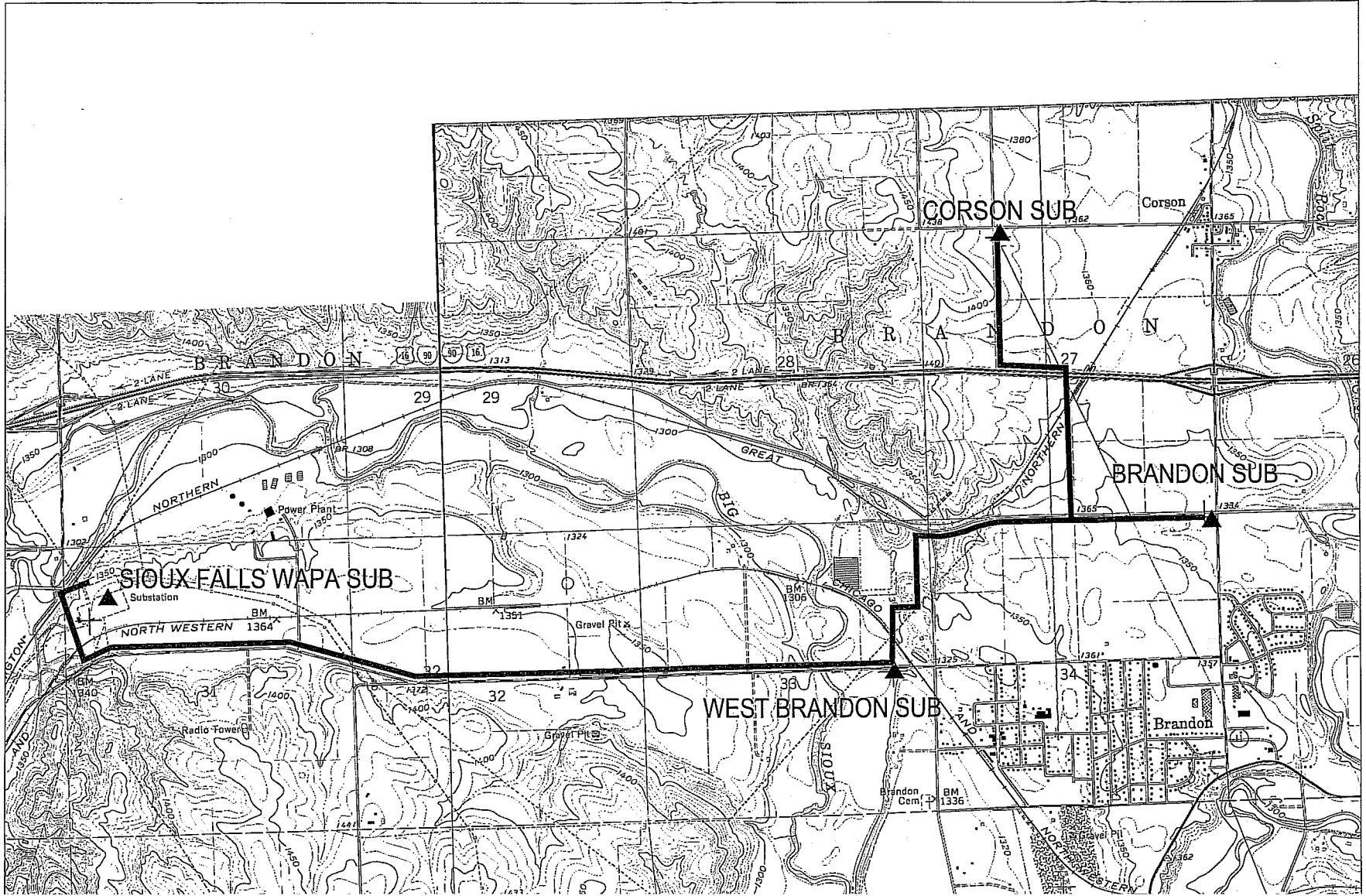
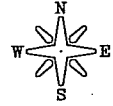

Exp. 46

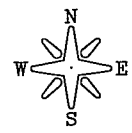
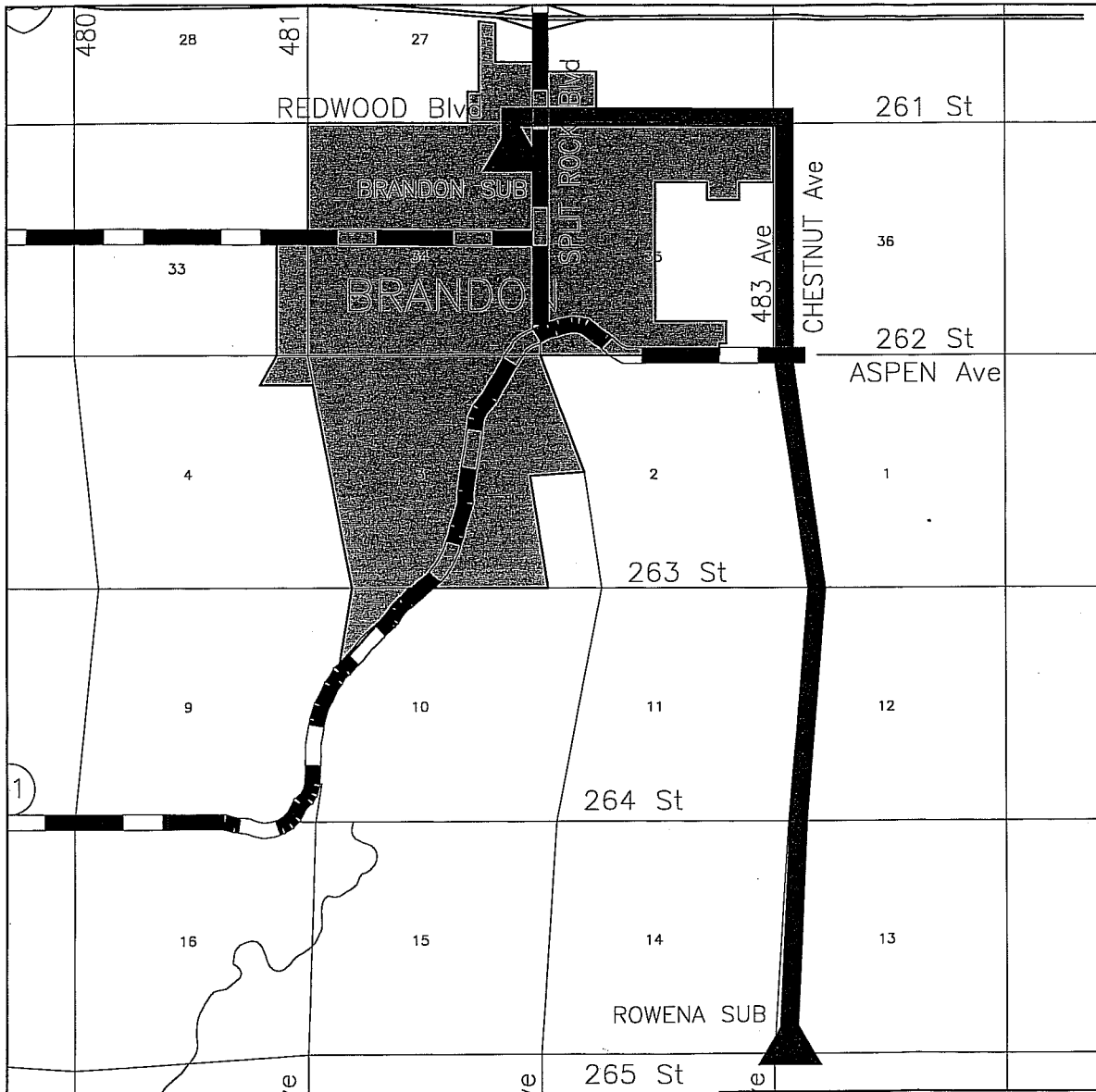





-  EXISTING 69KV FACILITIES
-  EXISTING 69KV LINE UPGRADE TO 115KV
-  EXISTING 69KV SUB UPGRADE TO 115KV
-  MUNICIPALITY

Fig. 5

| | | |
|--|----------|------------|
| A Touchstone Energy [®] Cooperative  | | |
| PCFP FILE: ERTYPLT | | |
| DATE 11-18-03 | W.D. NO. | SCALE NONE |



MAVRSEYDA

SIoux FALLS AREA
115KV CONVERSION
PROJECT - PART 2

SIoux FALLS AREA TRANSMISSION UPGRADE
PART 2

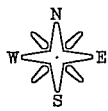

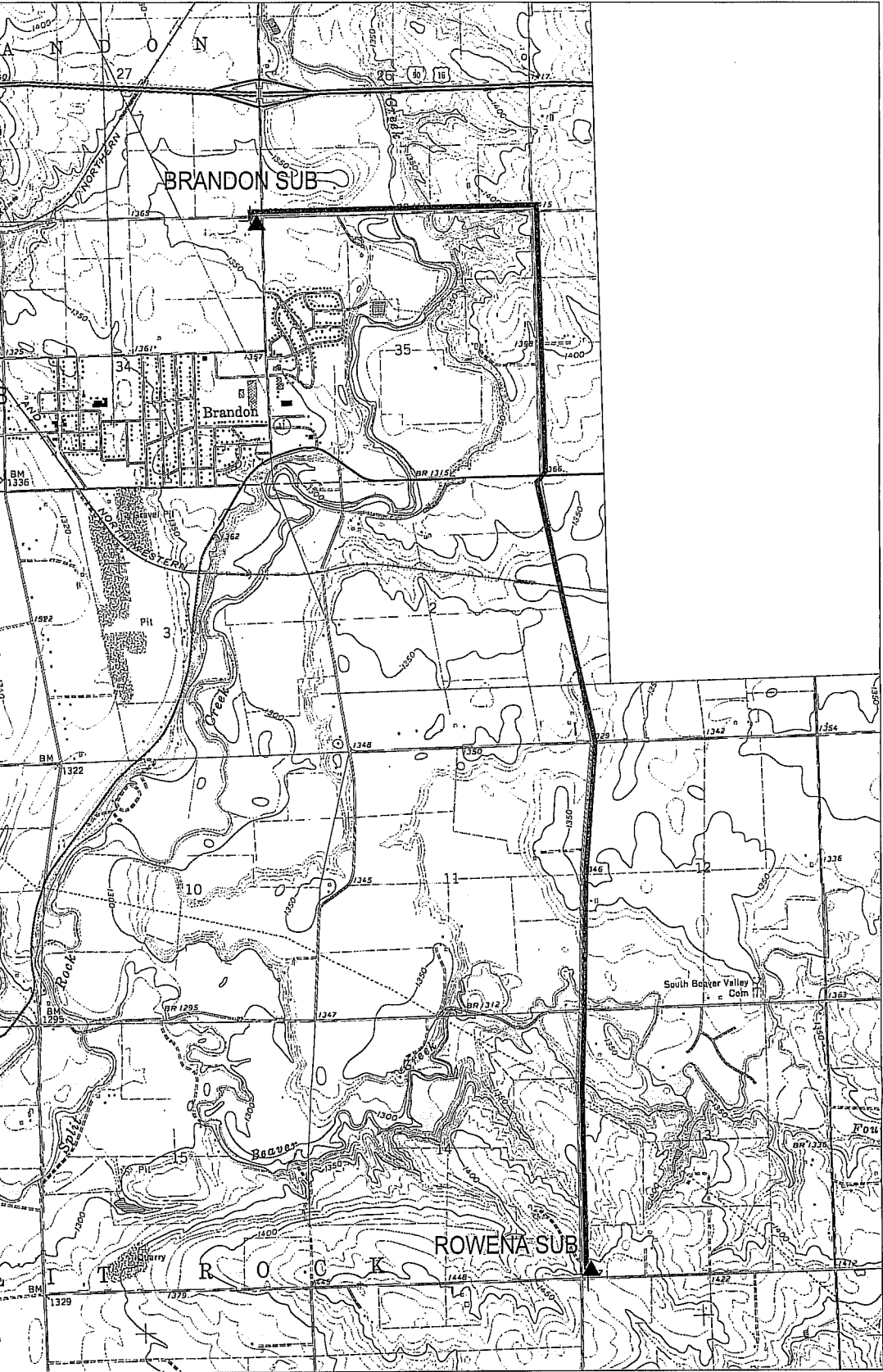

SIoux FALLS AREA TRANSMISSION UPGRADE
PART 2

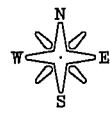

Sh. 5 b

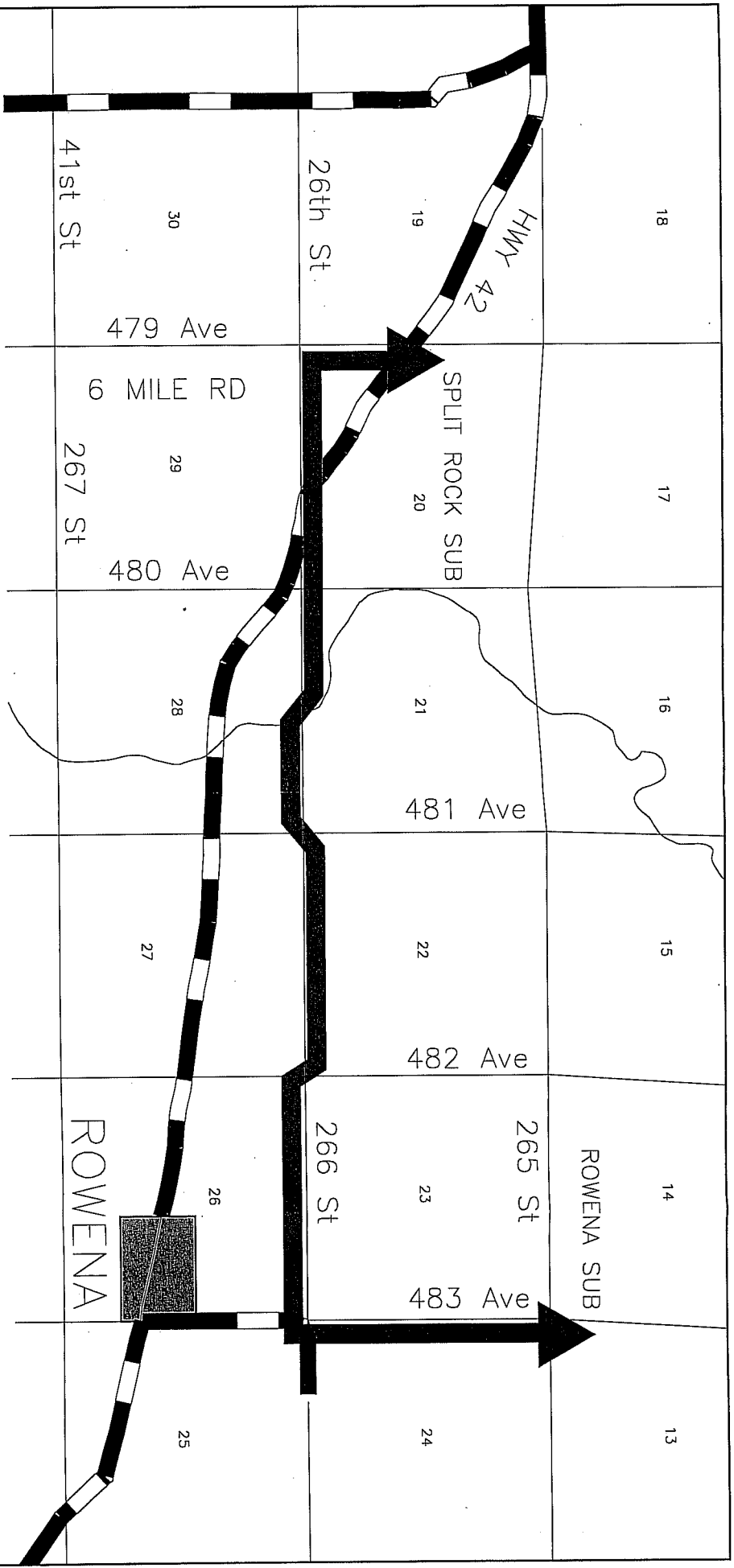

- ▲ EXISTING 69KV FACILITIES
- EXISTING 69KV LINE UPGRADE TO 115KV
- ▲ EXISTING 69KV SUB UPGRADE TO 115KV

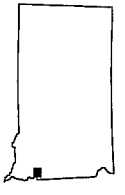
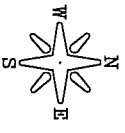

MUNICIPALITY

A Touchstone Energy* Cooperative

PPP FILE: ERTYPLT

DATE 11-18-03

W/O. NO.

SCALE NONE

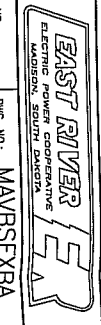

SIoux FALLS AREA
115KV CONVERSION
PROJECT - PART 3

Edh-b

SIoux FALLS AREA TRANSMISSION UPGRADE
PART 3

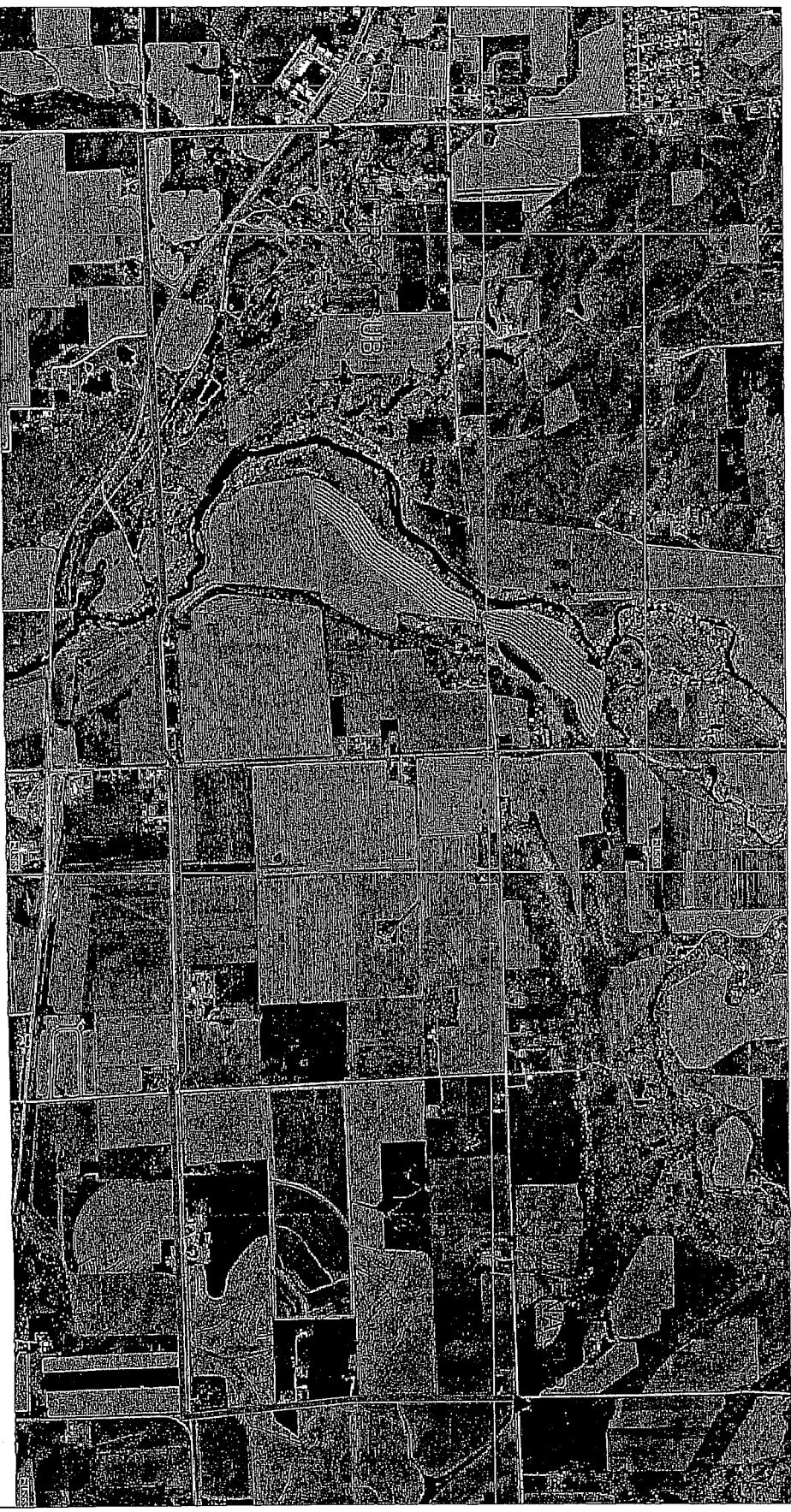
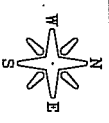



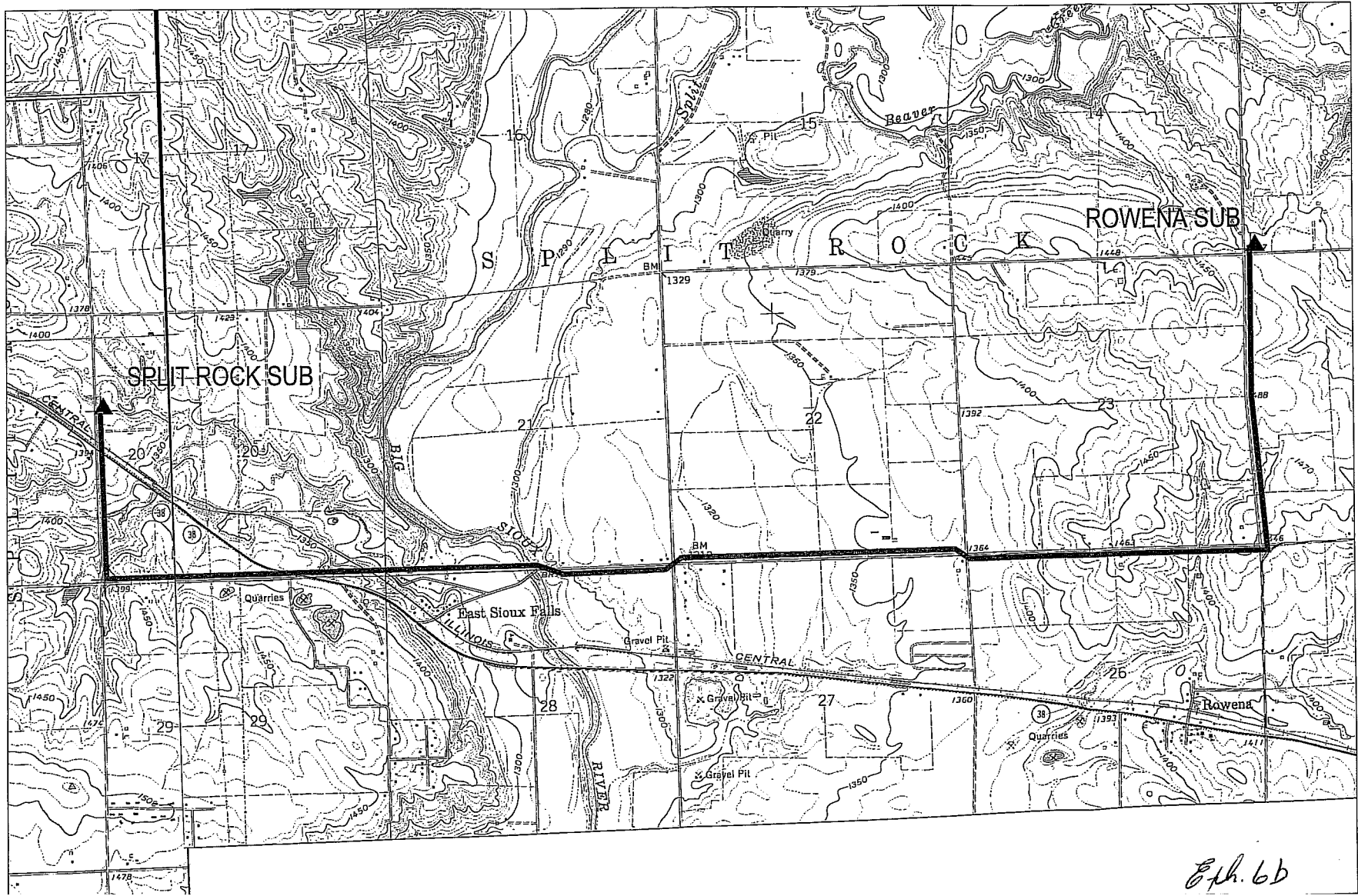
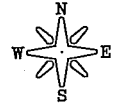

E.M. ba

SIoux FALLS AREA TRANSMISSION UPGRADE PART 3

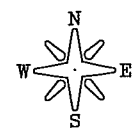
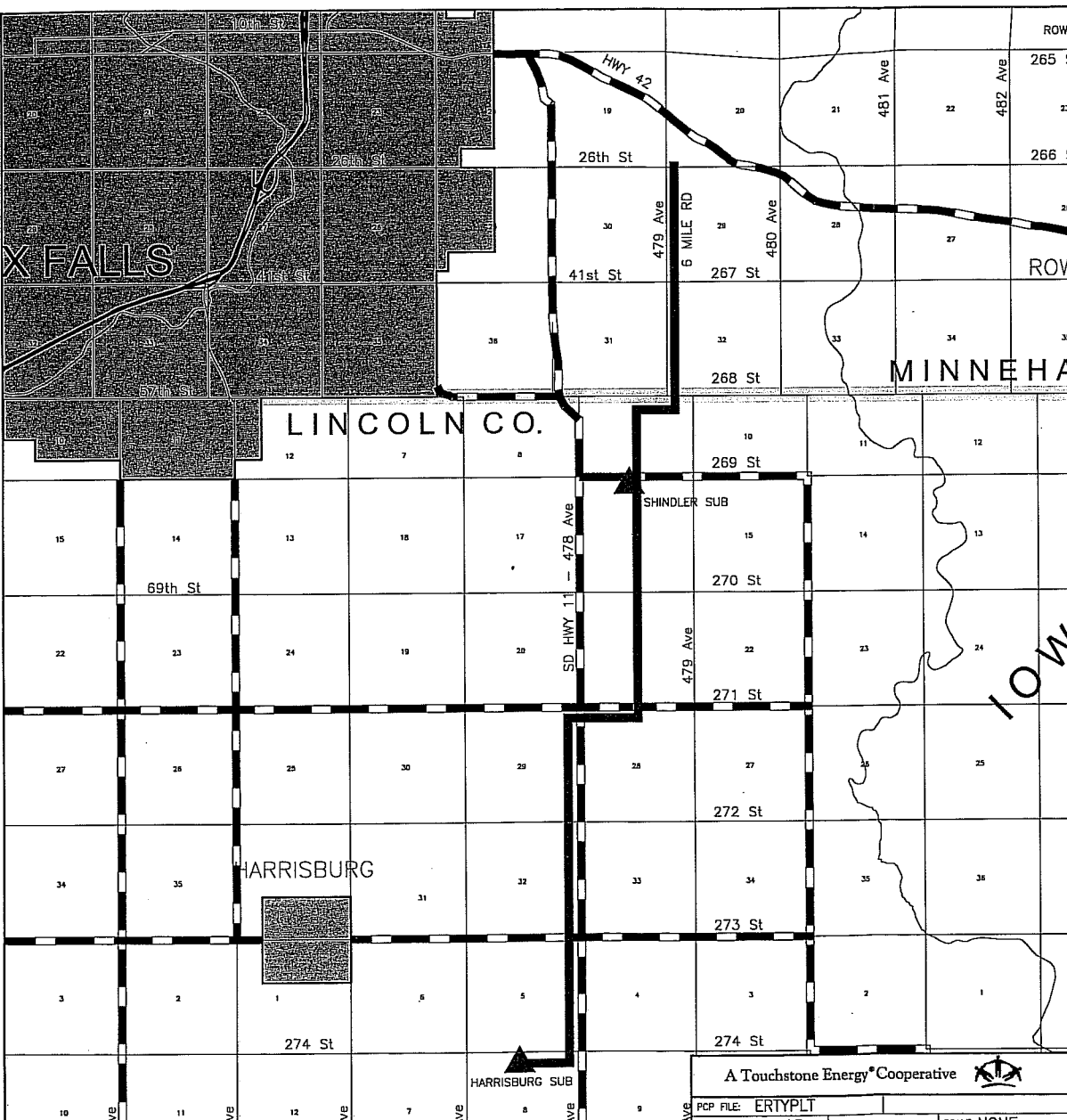

Eph. 6b



-  EXISTING 69KV FACILITIES
-  EXISTING 69KV LINE UPGRADE TO 115KV
-  EXISTING 69KV SUB UPGRADE TO 115KV
-  MUNICIPALITY

A Touchstone Energy Cooperative 

PCP FILE: ERTYPLT
 DATE 11-18-03 | W.O. NO. | SCALE NONE



Exp. 7
 SIOUX FALLS AREA
 115KV CONVERSION
 PROJECT - PART 4

SIOUX FALLS AREA TRANSMISSION UPGRADE
PART 4

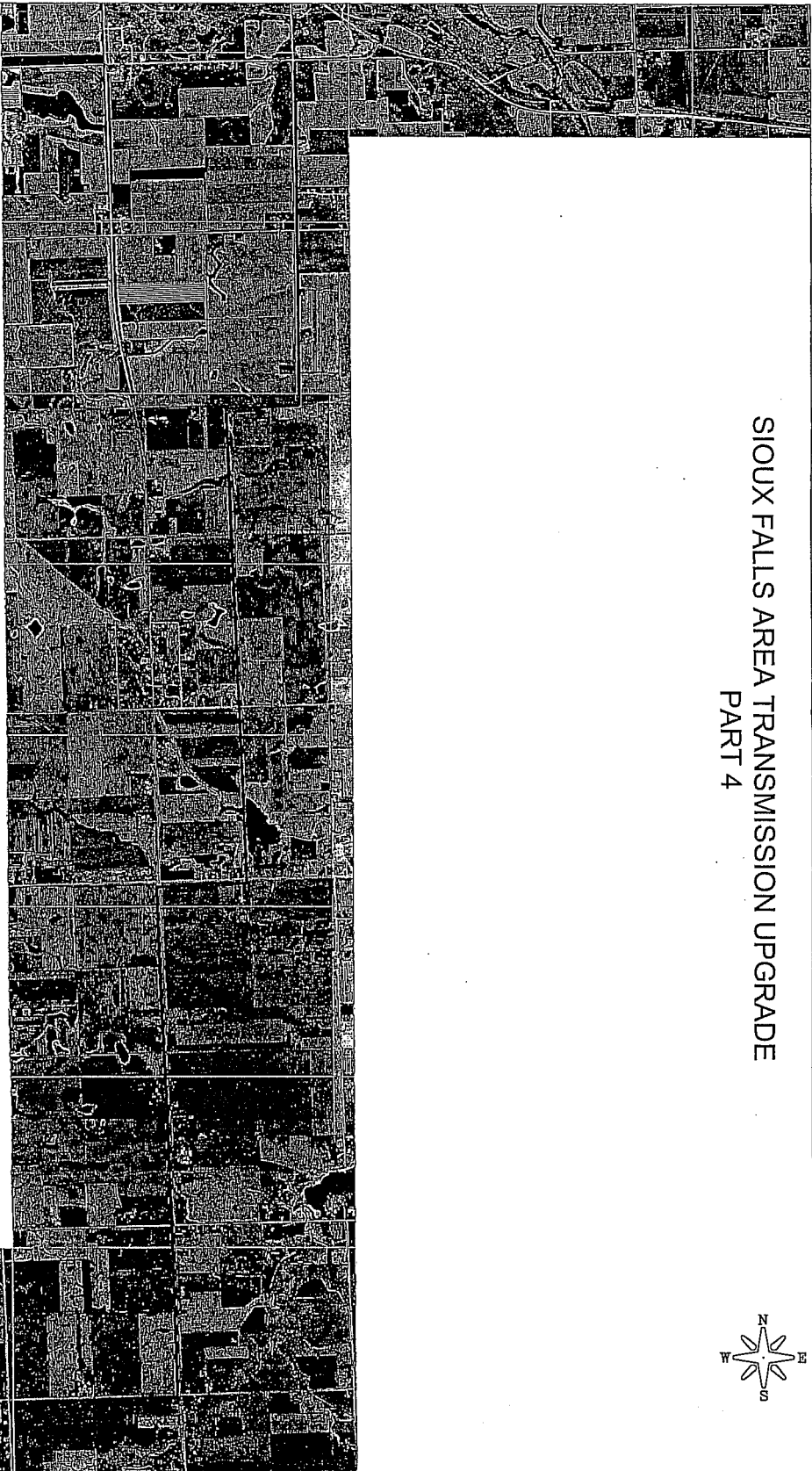
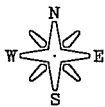



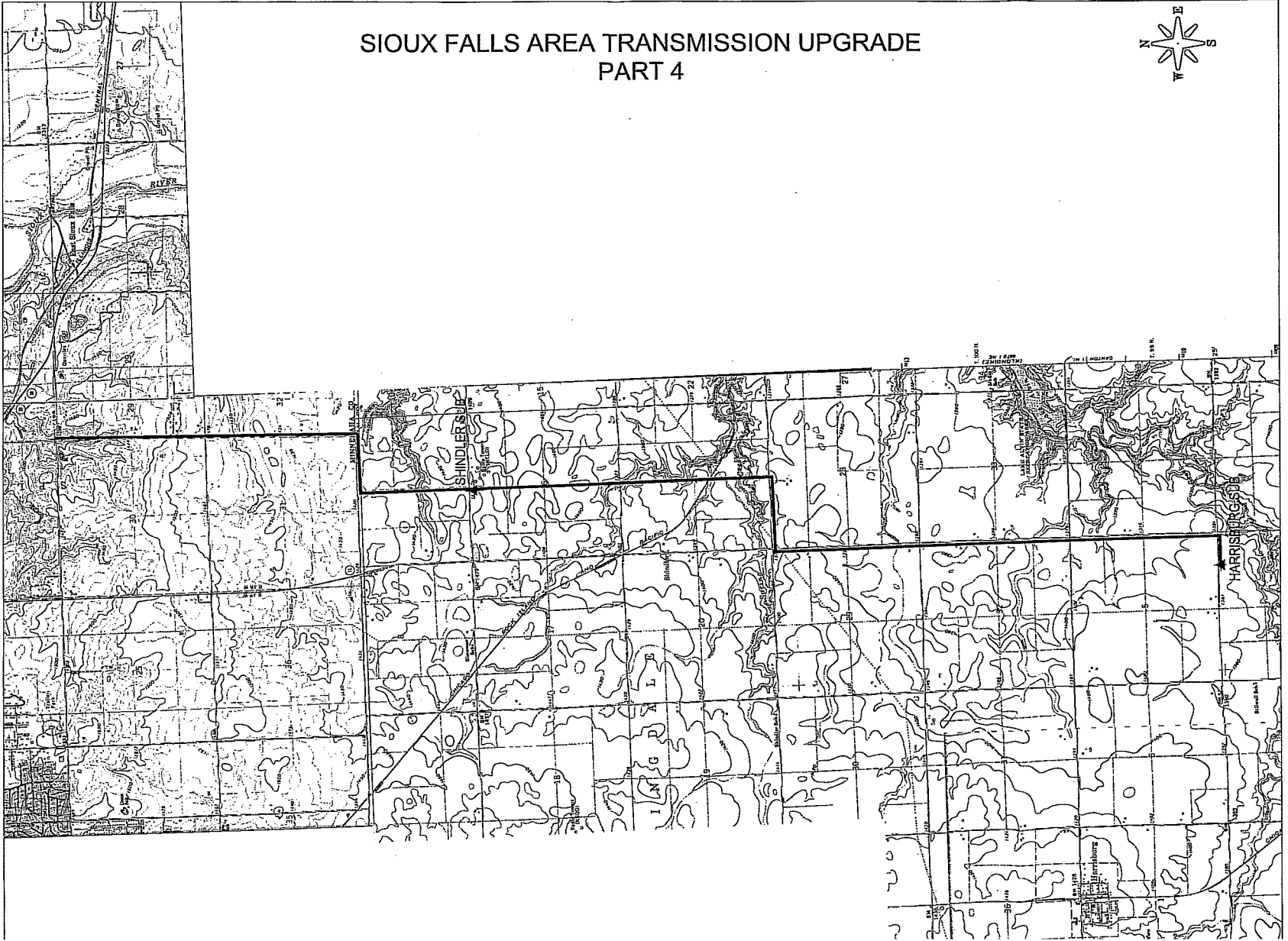
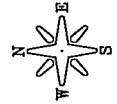

2074

SIoux FALLS AREA TRANSMISSION UPGRADE
PART 4

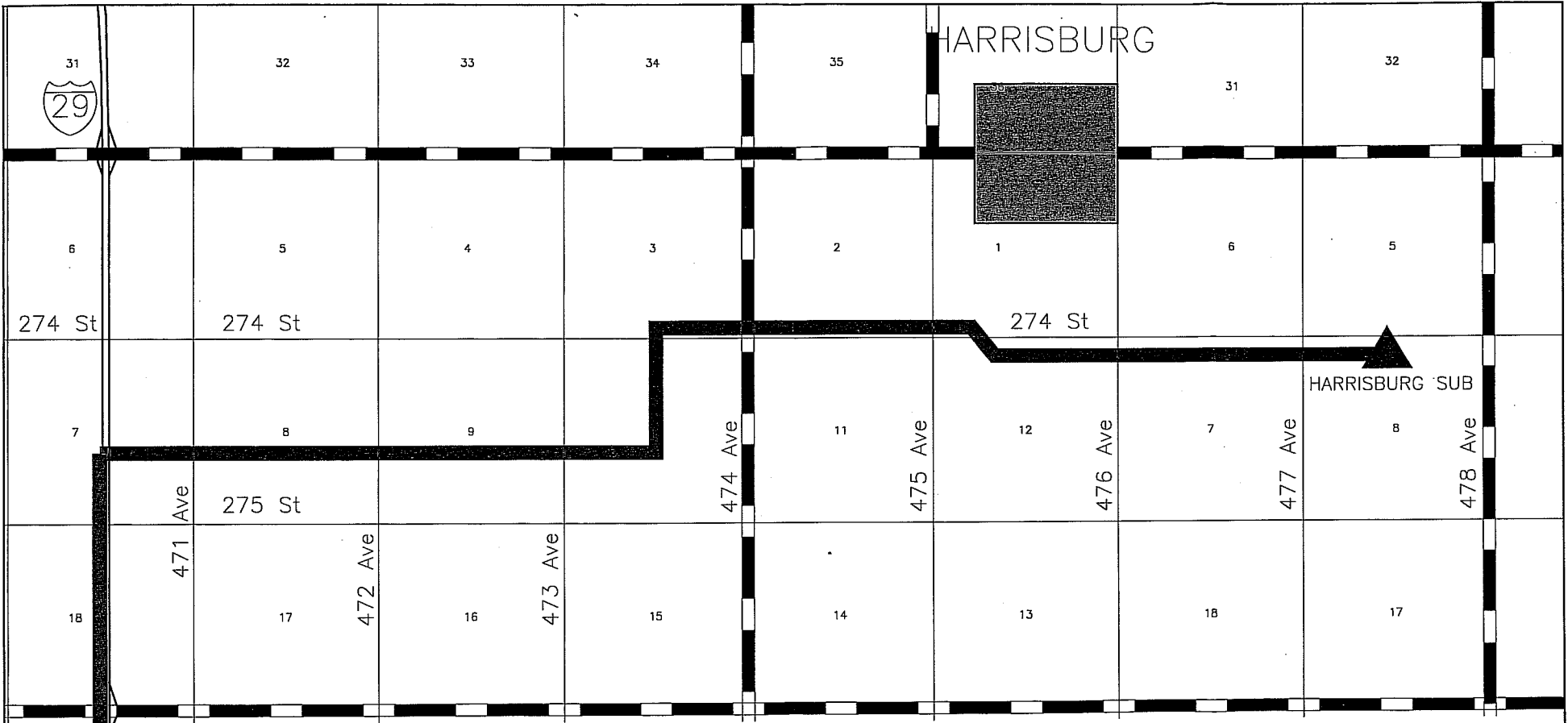

Exh. 76



-  EXISTING 69KV FACILITIES
-  EXISTING 69KV LINE UPGRADE TO 115KV
-  EXISTING 69KV SUB UPGRADE TO 115KV

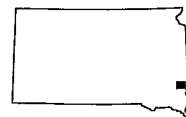
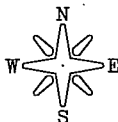

 MUNICIPALITY

| | | |
|--|----------|------------|
| A Touchstone Energy [®] Cooperative  | | |
| PCP FILE: ERTYPLT | W.O. NO. | SCALE NONE |
| DATE 11-18-03 | | |



Exh. 8

SIOUX FALLS AREA
115KV CONVERSION
PROJECT - PART 5

SIoux FALLS AREA TRANSMISSION UPGRADE
PART 5

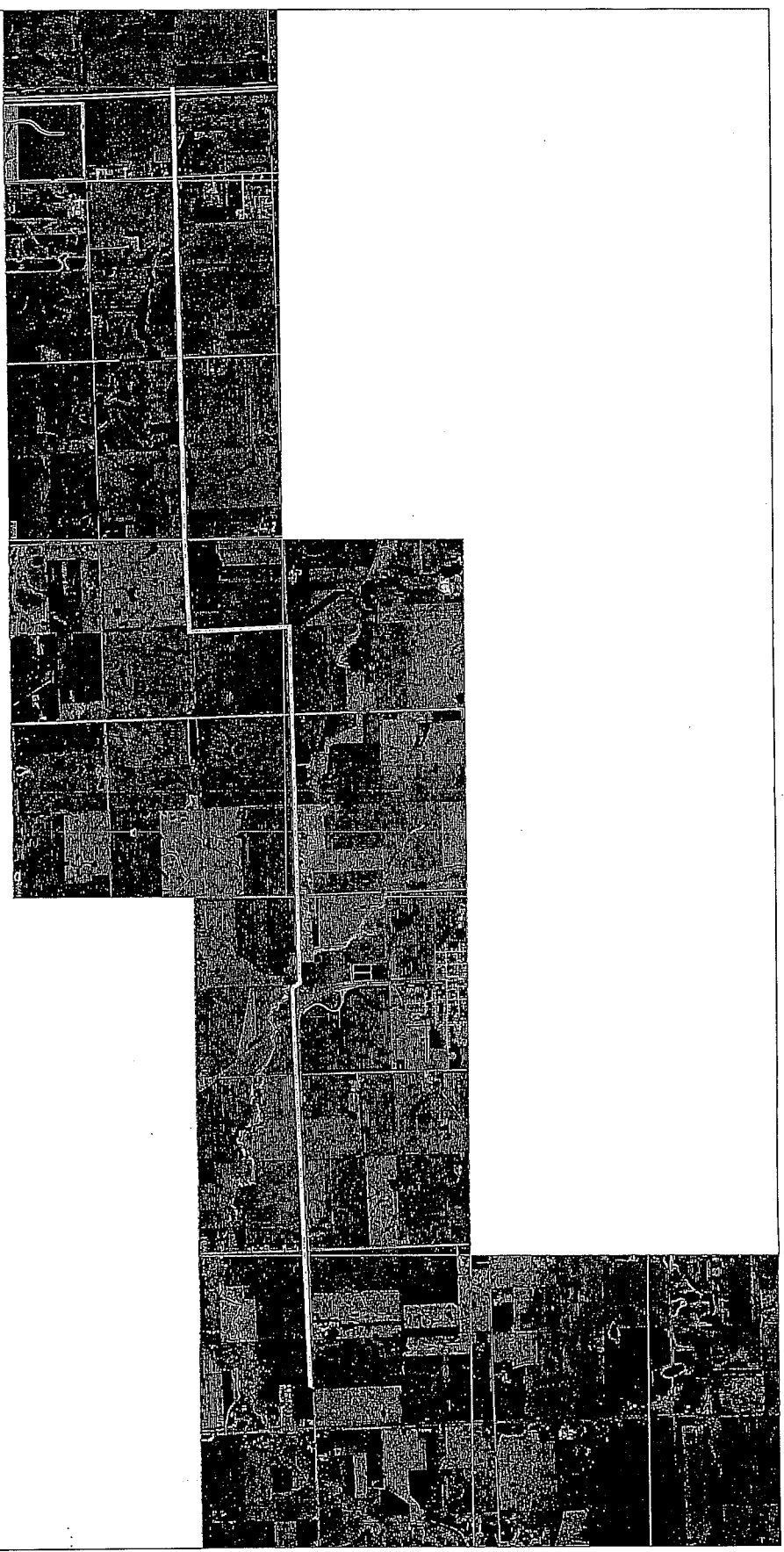

5/16/01

SIoux FALLS AREA TRANSMISSION UPGRADE
PART 5

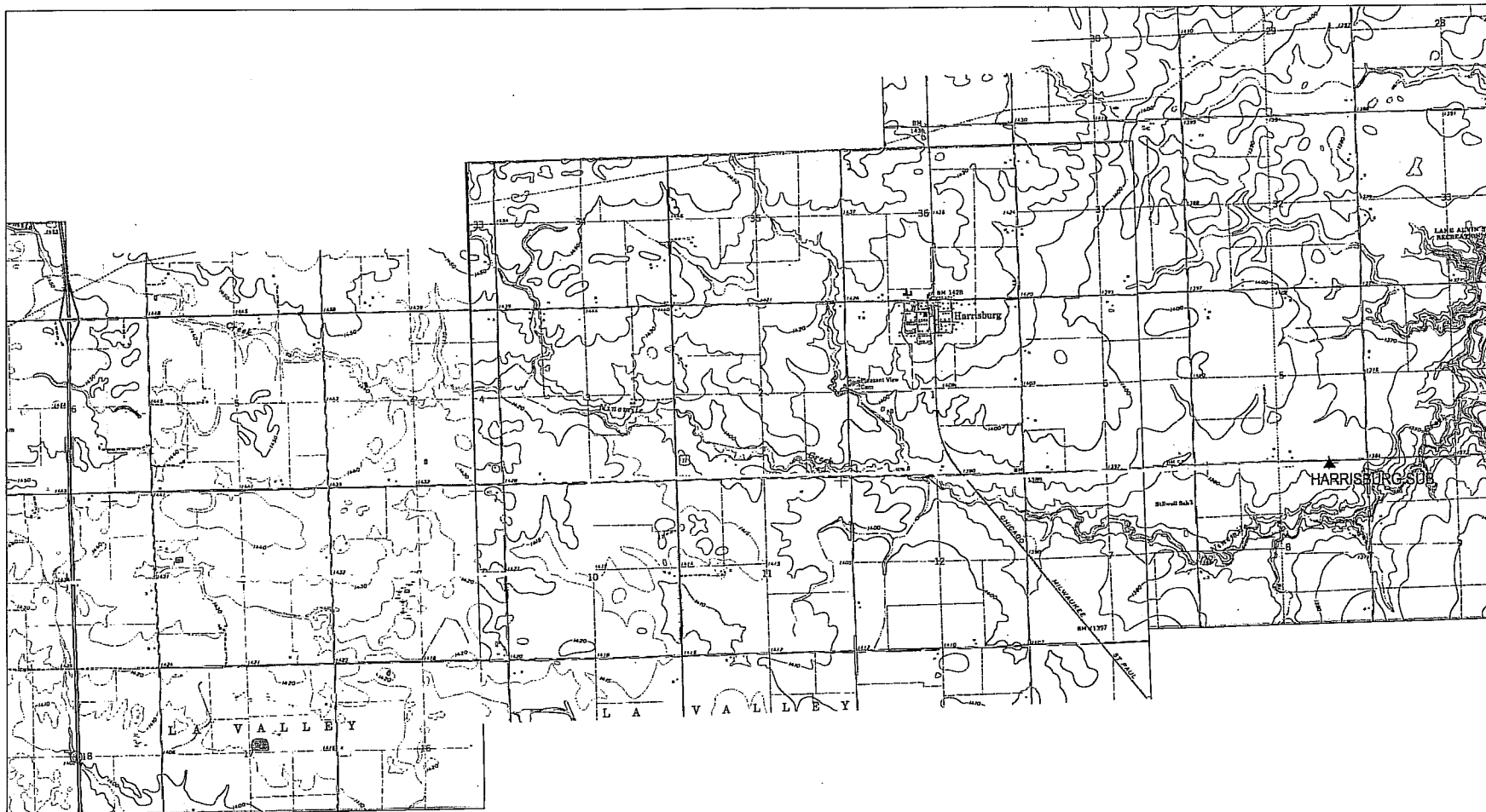
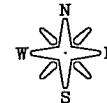

Exp. 8b

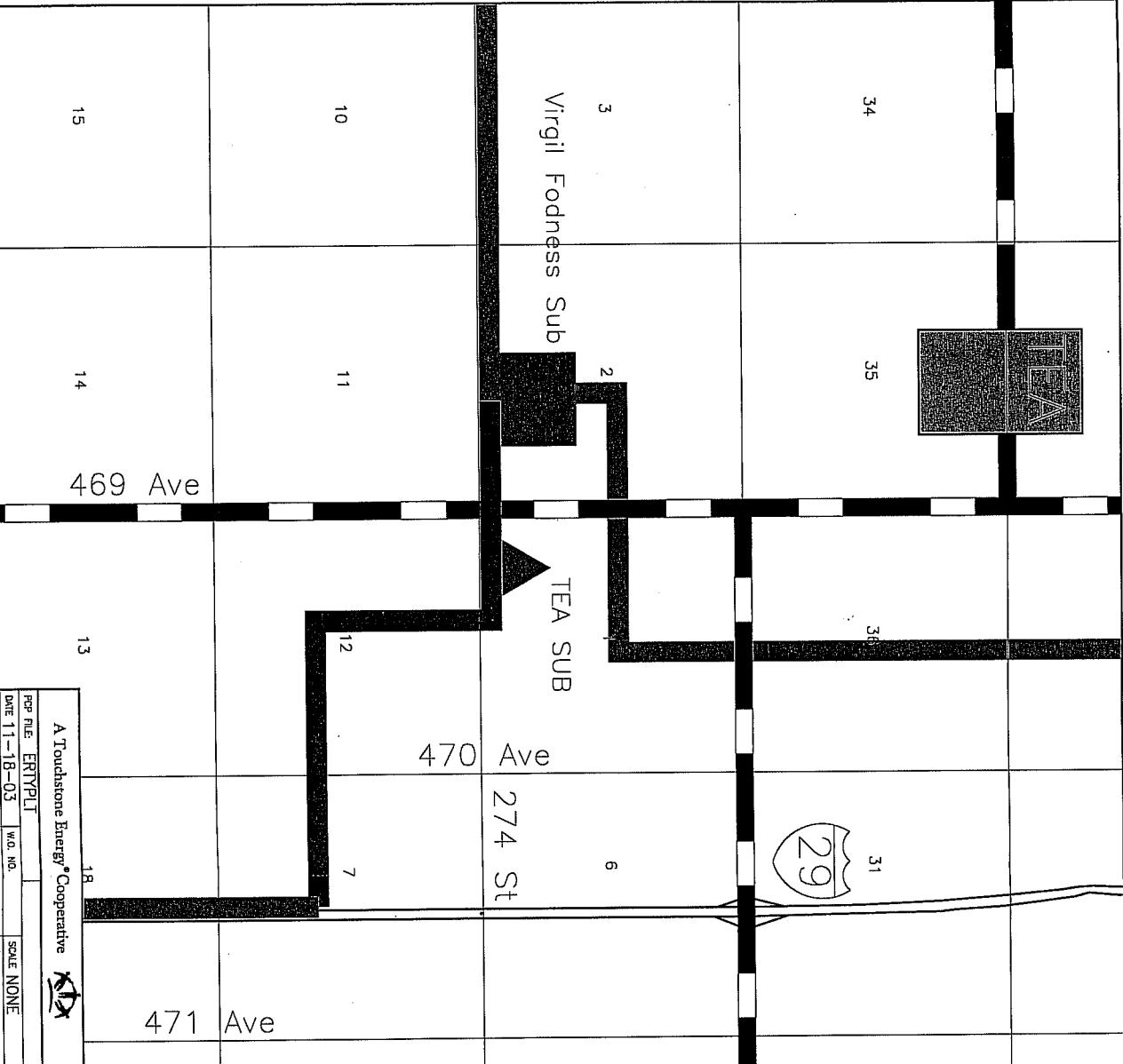

A Touchstone Energy Cooperative
 PEP FILE: ERTYPLT
 DATE 11-18-03
 WGS. NO.
 SCALE NONE

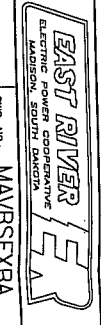

SIoux FALLS AREA
 115KV CONVERSION
 PROJECT - PART 6

- ▲ EXISTING 69KV FACILITIES
- EXISTING 69KV LINE UPGRADE TO 115/69KV DOUBLE CIRCUIT
- ▲ EXISTING 69KV SUB UPGRADE TO 115KV

■ MUNICIPALITY

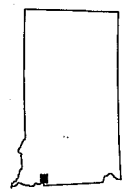

SIoux FALLS AREA TRANSMISSION UPGRADE
PART 6

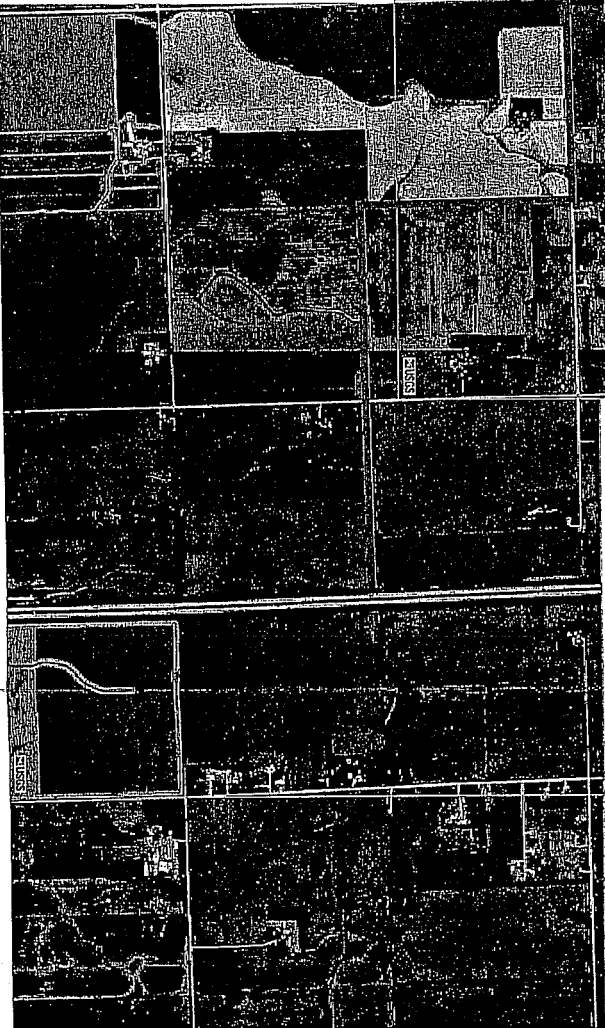

212

SIoux FALLS AREA TRANSMISSION UPGRADE
PART 6

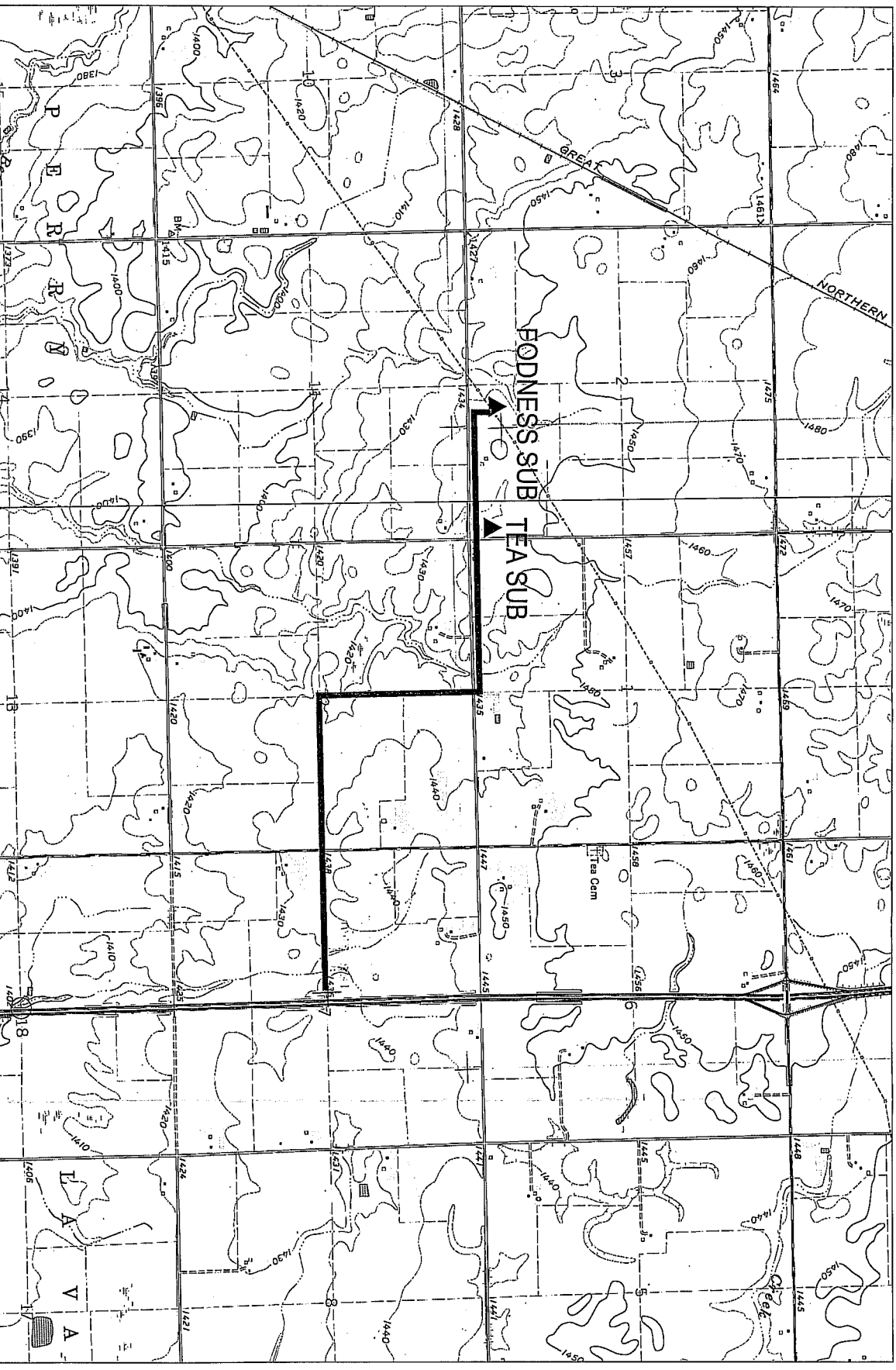

Ed. 96



Project Crossing Crop Land



Project Adjoining Residential Area

Exhibit 11

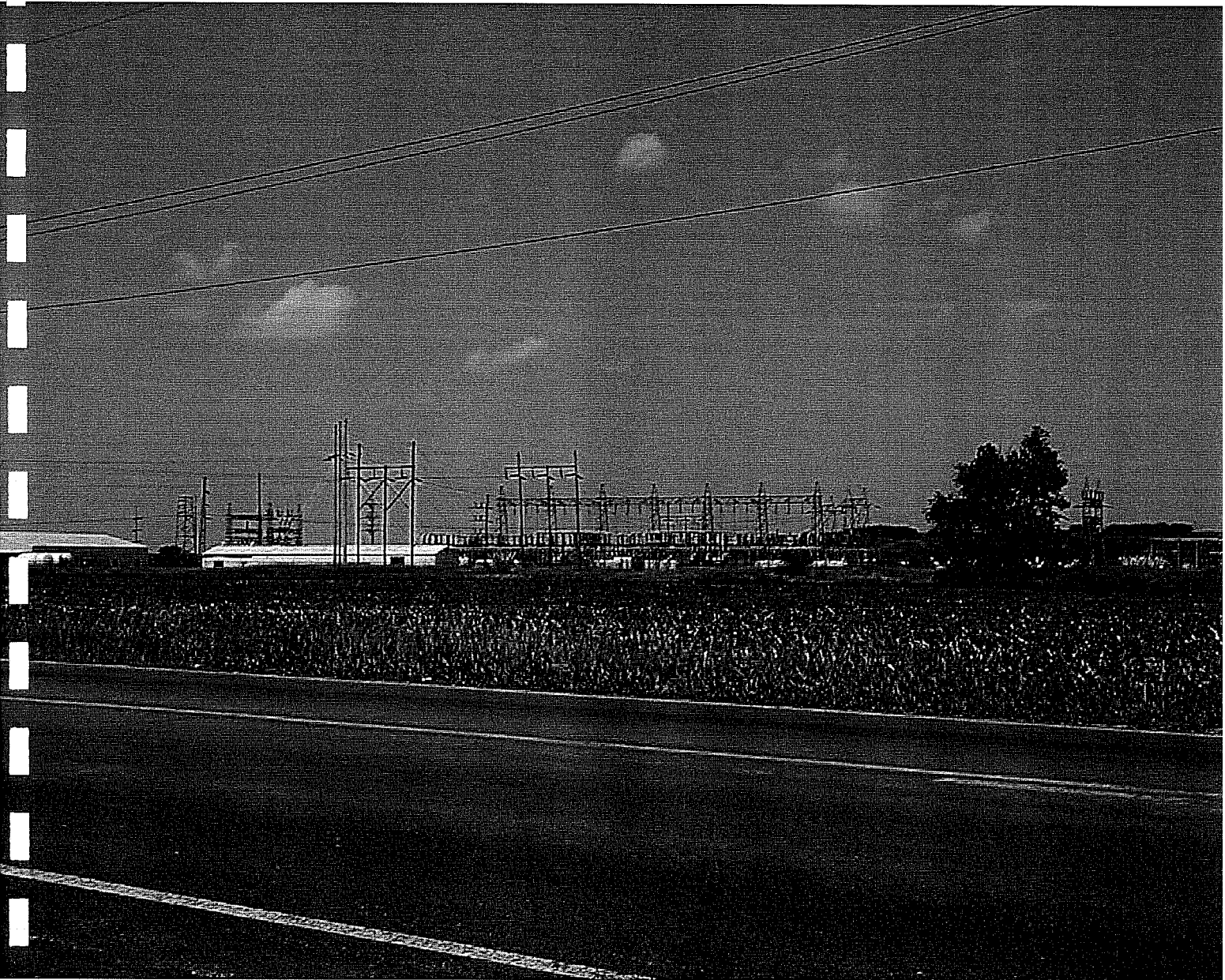

WAPA's Sioux Falls Substation

Exhibit 12

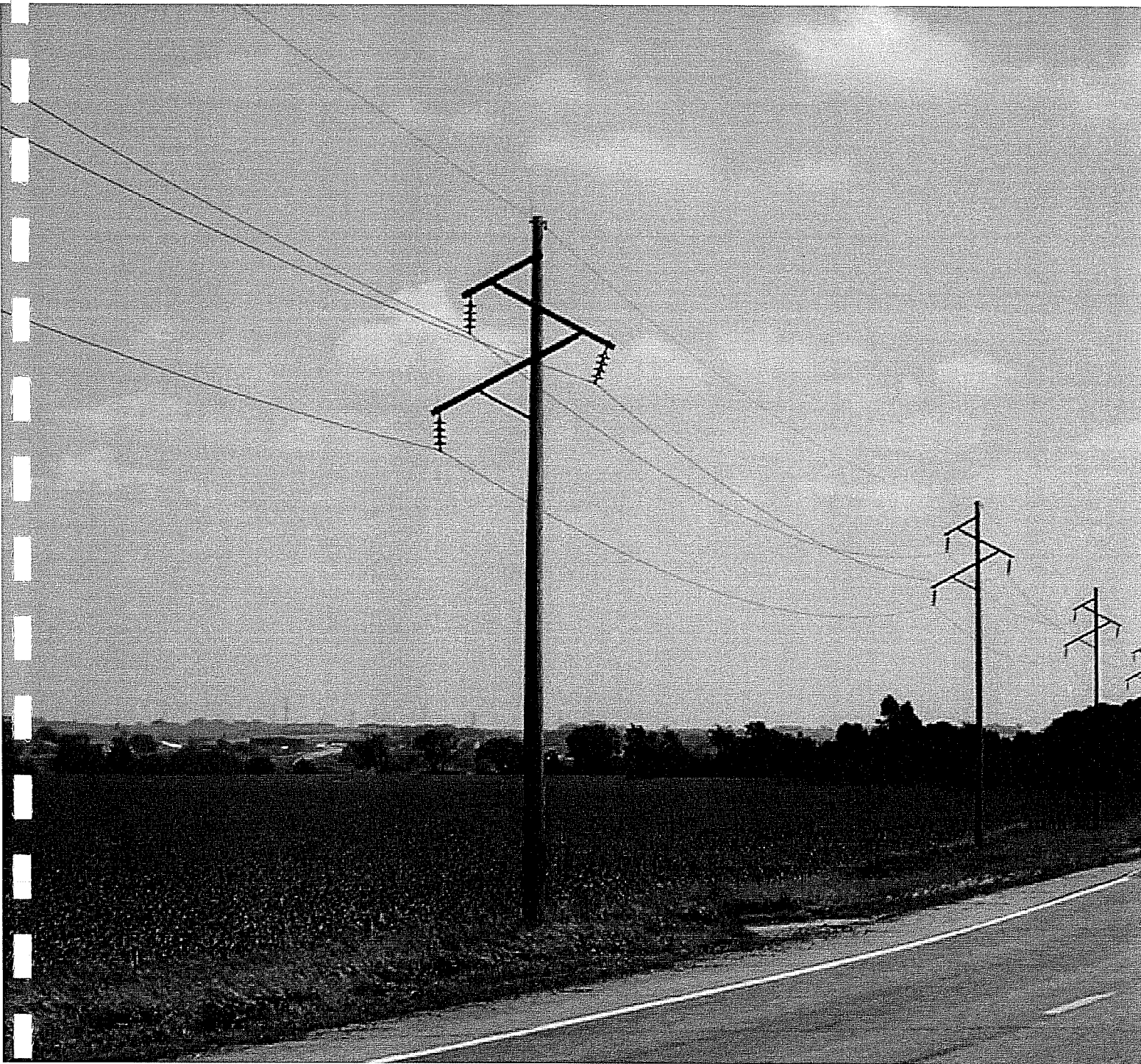

69Kv Line Structure with Suspension Insulators

Exhibit 13



Side Mount 115 kV Insulators

Exhibit 14

ONE BOLT STATIC BRACKET

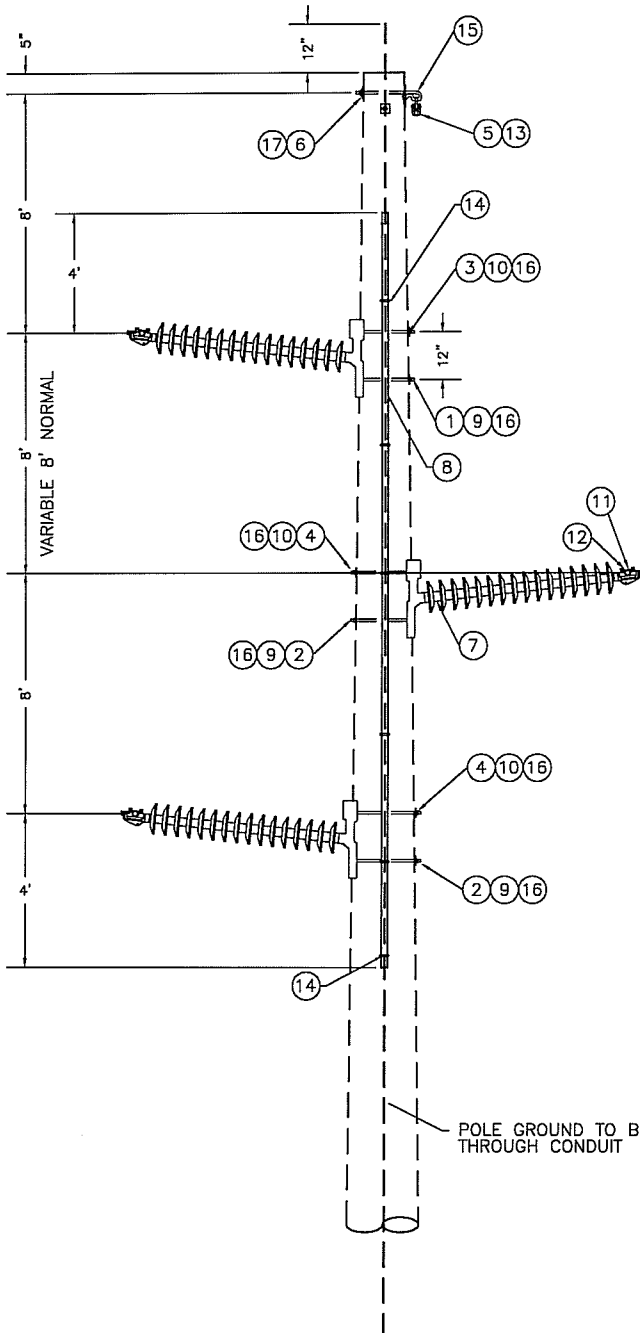

TWO BOLT STATIC BRACKET

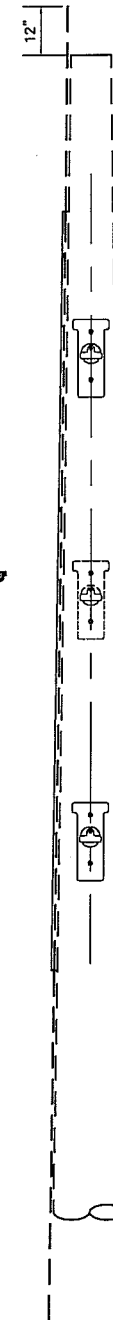
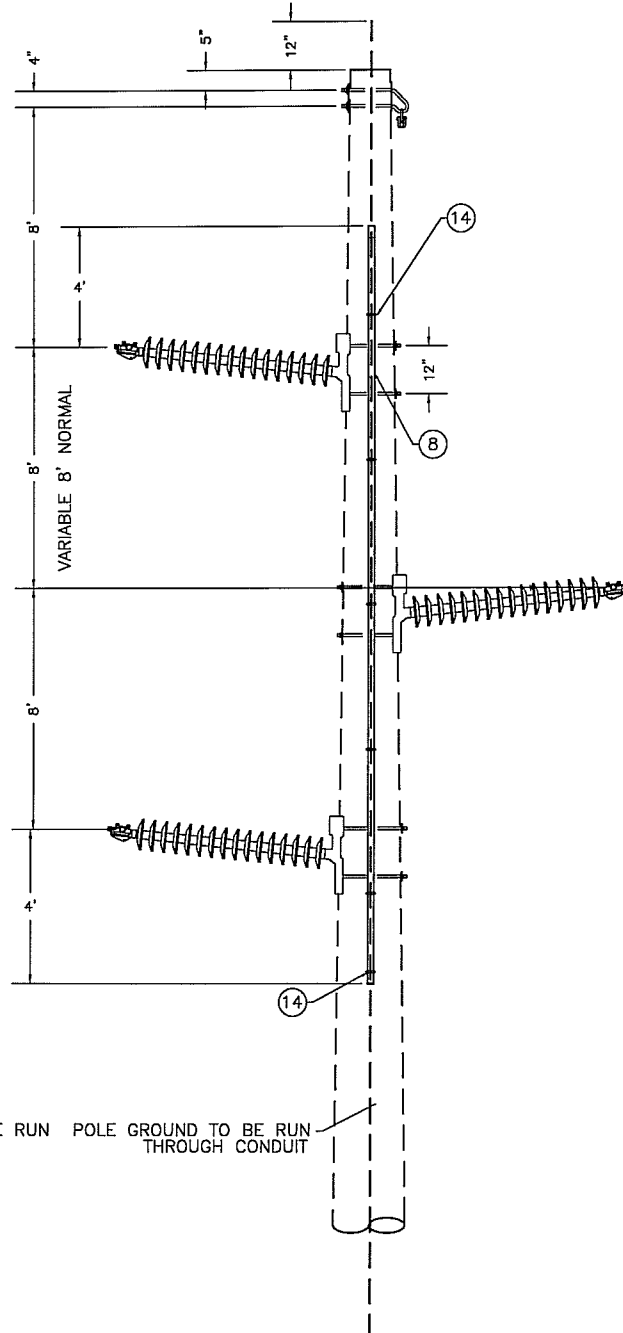

NOTES:

1. STAPLE AT LEAST EVERY 3'. LEAVE CONDUIT SLIGHTLY LOOSE TO ALLOW CONDUIT TO EXPAND.
2. DRIVE STAPLE HALFWAY IN JUST BELOW AND ABOVE CONDUIT TO PREVENT CONDUIT FROM SLIDING.
3. CONDUIT LENGTH MAY VARY BASED ON INSULATOR SPACING.
4. SEE STAKING SHEET OR PROFILES FOR INSULATOR SPACINGS.

| | | | |
|-------------|-------------|---|------------|
| DATE | REV. | EAST RIVER | |
| | | ELECTRIC POWER COOPERATIVE MADISON, SOUTH DAKOTA | |
| TP-Y1-F-115 | | | |
| DATE | 3-26-02 | E.R. CAD DWG. NO.: | SCALE |
| W.D. NO. | TP-Y1-F-115 | | N.T.S. |
| DWN. BY | T.J.R. | DWNL. FOR | SHEET OF |
| | | | PLYT SCALE |



69 kV Two Pole Line Structure with Suspension Insulators



TH-1S-115

| | | | | | |
|----------|---------|------------------|-----------|------------|------------|
| DATE | 1-19-04 | EA. CO. DWG. NO. | TH-1S-115 | SCALE | 1/2"=1'-0" |
| NO. REV. | | BY | | SHEET | OF |
| DRAWN BY | D.A.F. | DATE | | PLOT SCALE | 1/24 |

| DATE | REVISION |
|------|----------|
| | |
| | |
| | |

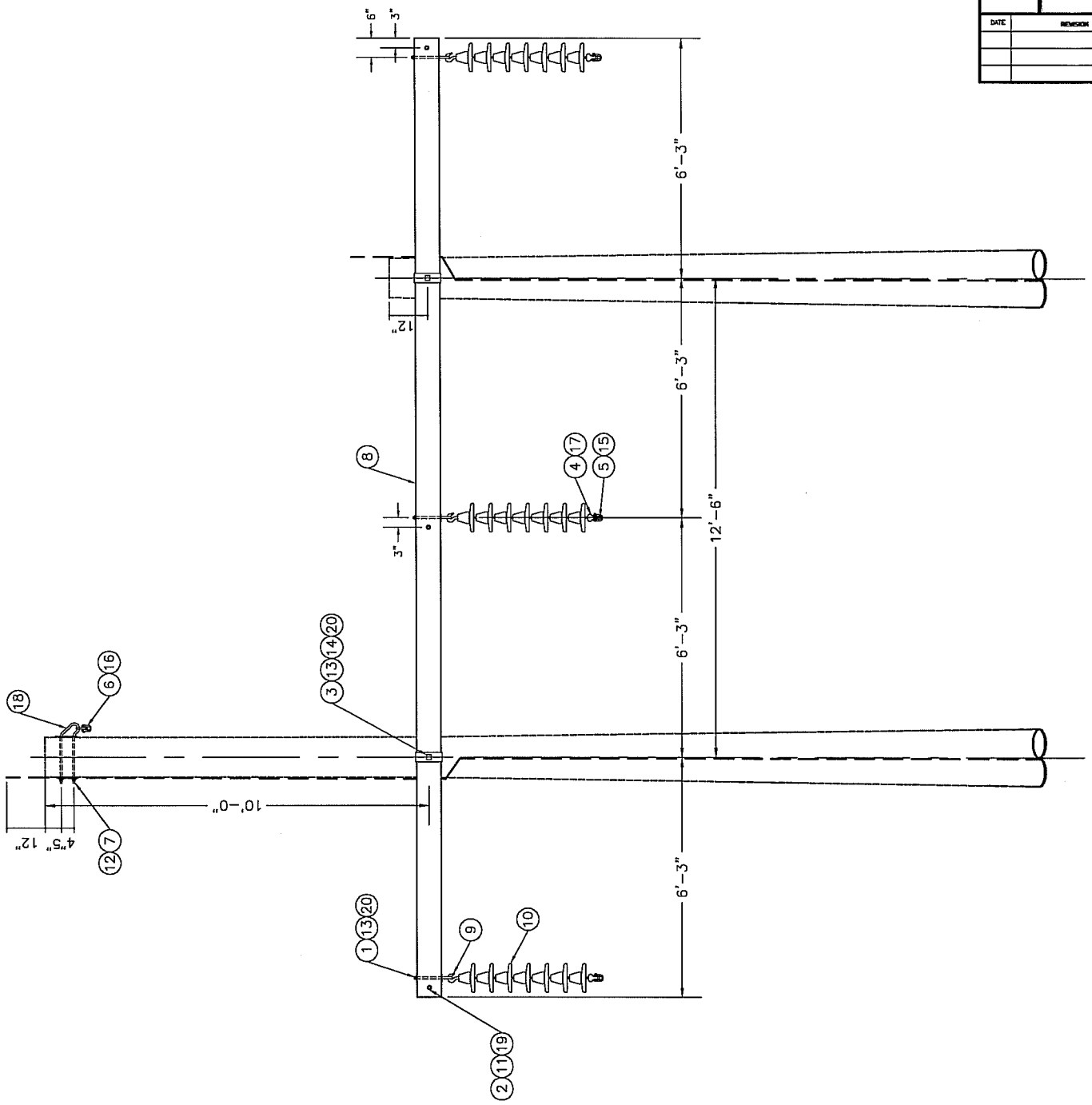

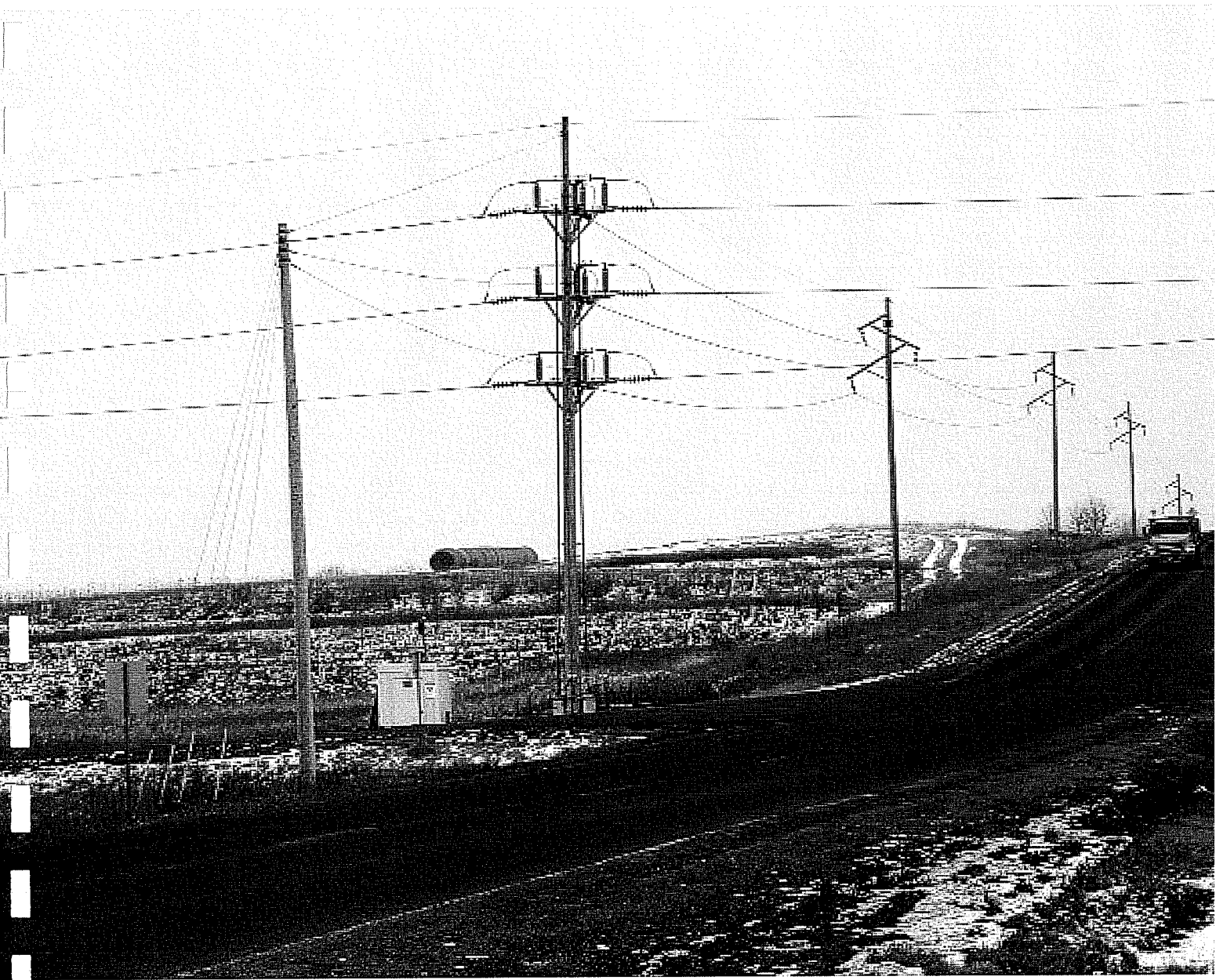

Line Switch, 226th Street and Six Mile Rd.

Exhibit 16

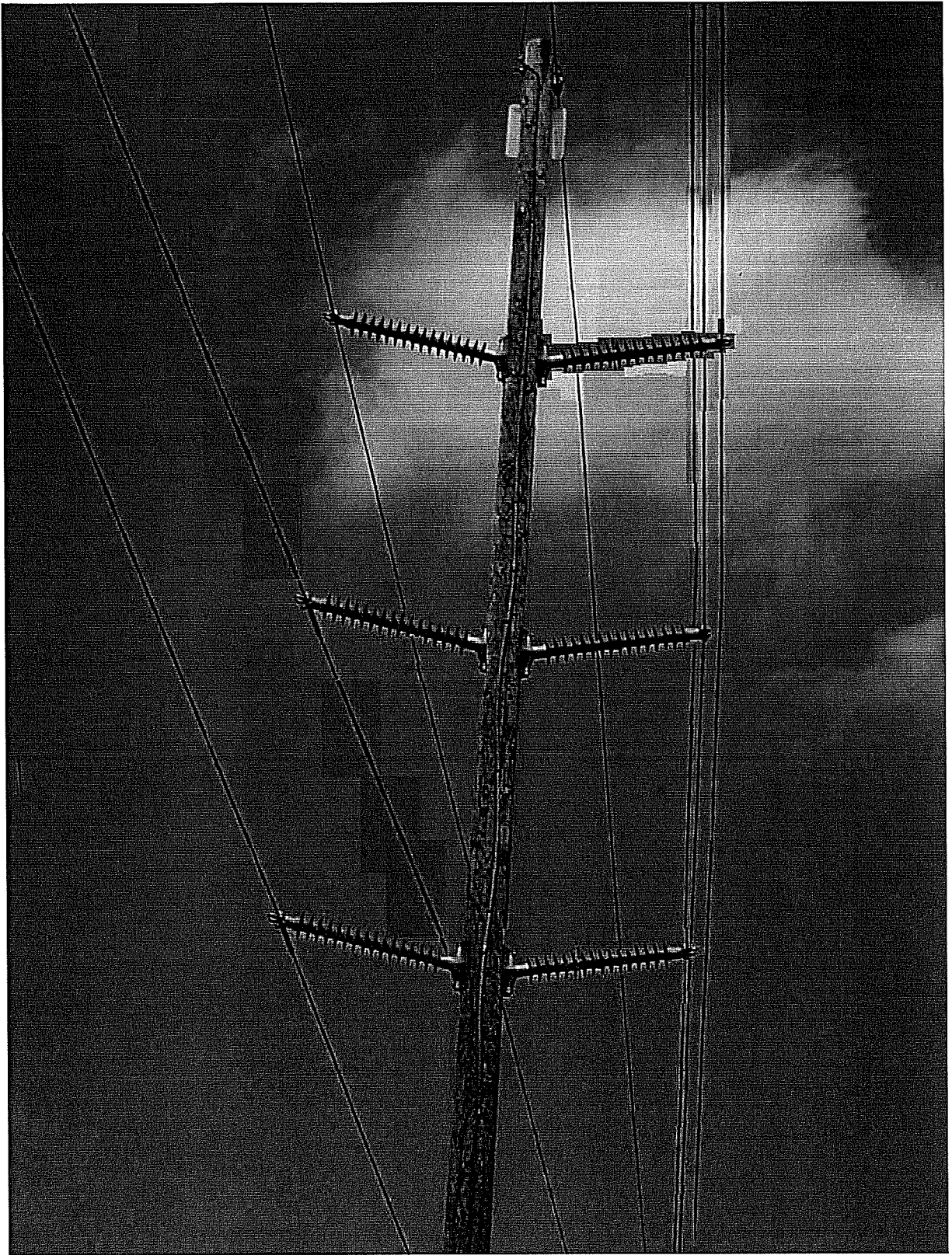

115 kV Single Pole Double Circuit

Exhibit 17



Line Paralleling Highway ROW

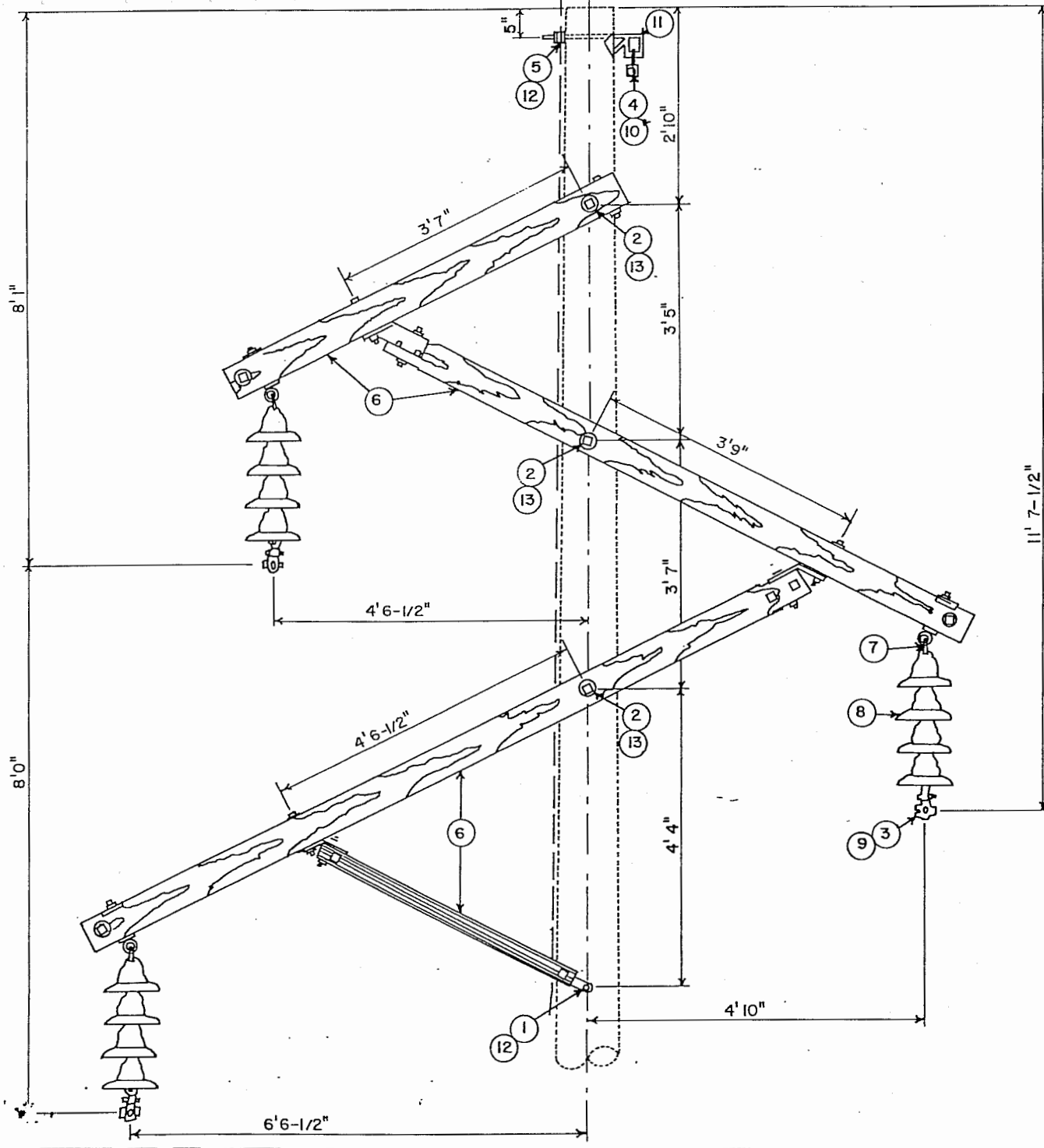

| | | |
|----------|---|--------------------|
| DATE | EAST RIVER ELECTRIC POWER COOPERATIVE, INC. | |
| | MADISON, S. DAKOTA | |
| REVISION | TSZ-31 | |
| | DATE 5/20/1976 | DWG. NO. ER — 3192 |
| BY | W.O. NO. | SHEET OF |
| | OWN. BY WHK | OWN. FOR |

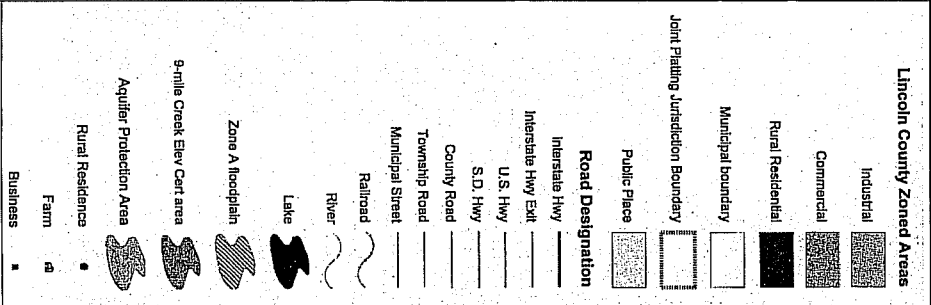
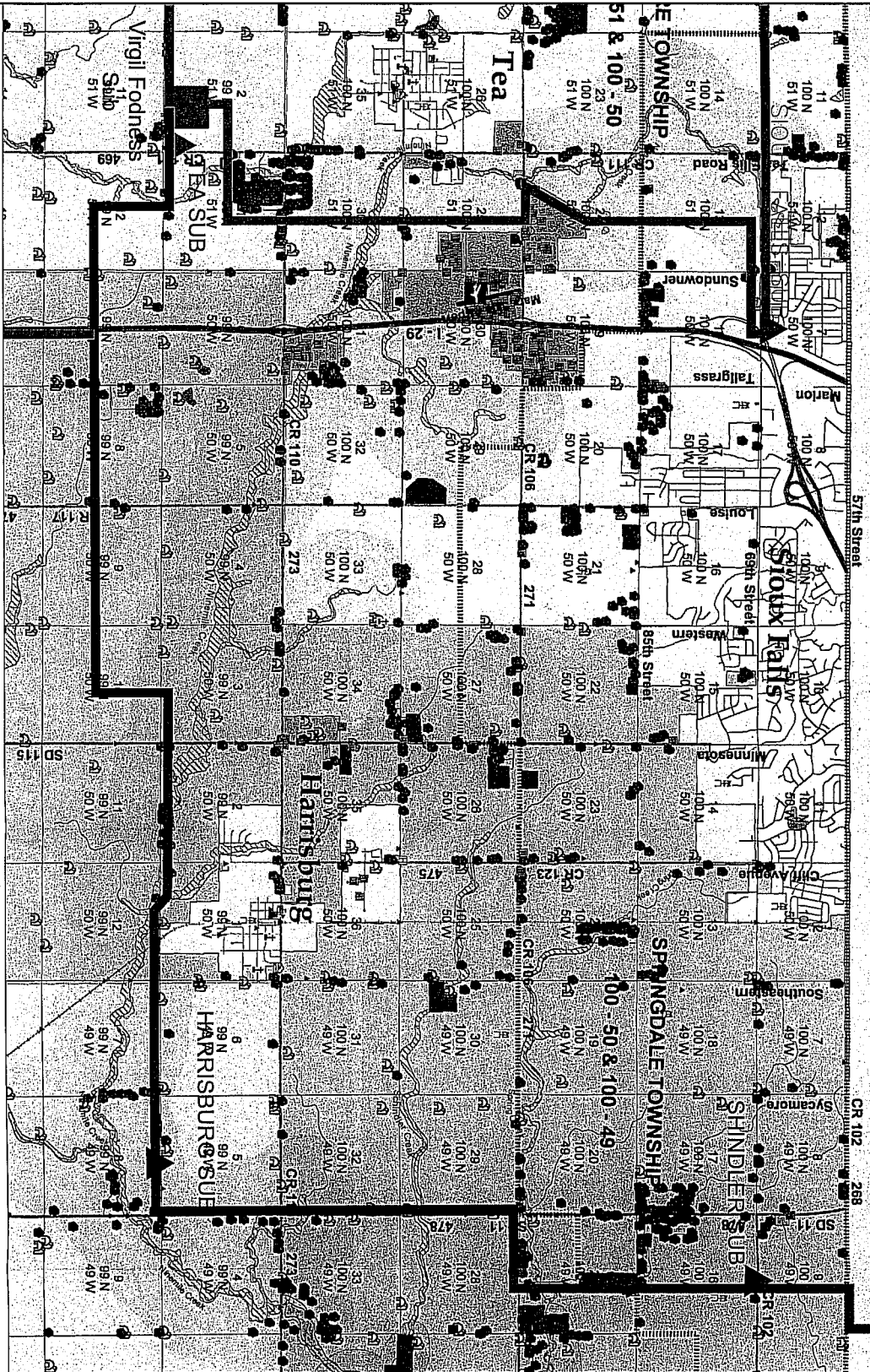

▲ EXISTING 69KV FACILITIES

— EXISTING 69KV LINE UPGRADE TO 115KV

▲ EXISTING 69KV SUB UPGRADE TO 115KV

A Touchstone Energy Cooperative



PDF FILE: ERTYPTLT

W.O. NO.

SCALE: NONE

DATE: 1-19-04



SIoux FALLS AREA
115KV CONVERSION PROJECT
LINCOLN CO. LAND USE

Edk. 20

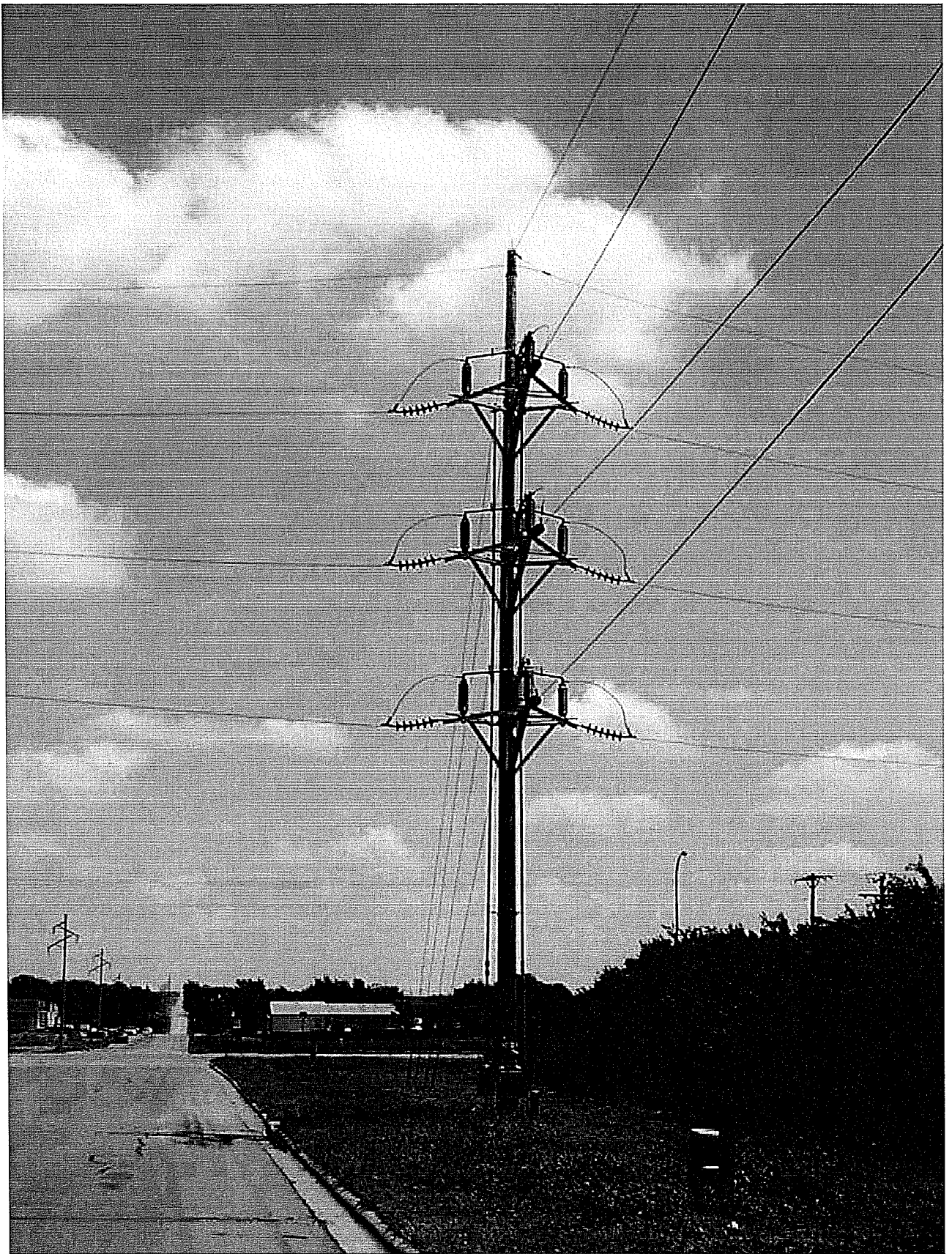

69 kV Line Switch

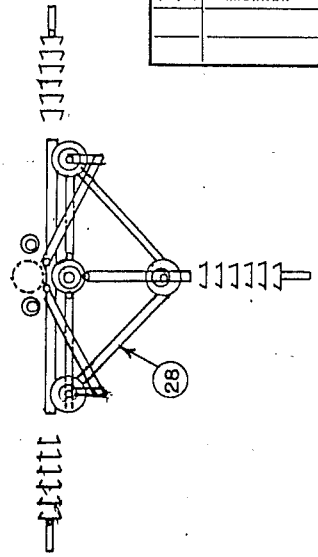
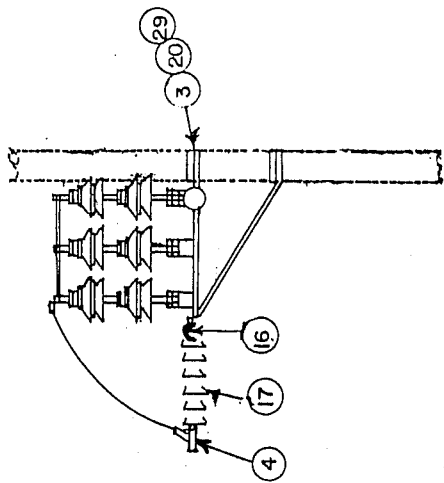
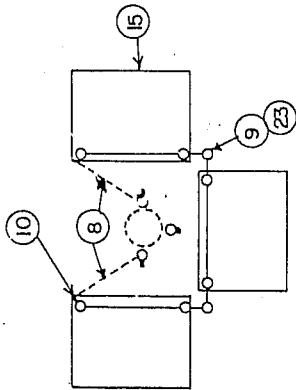
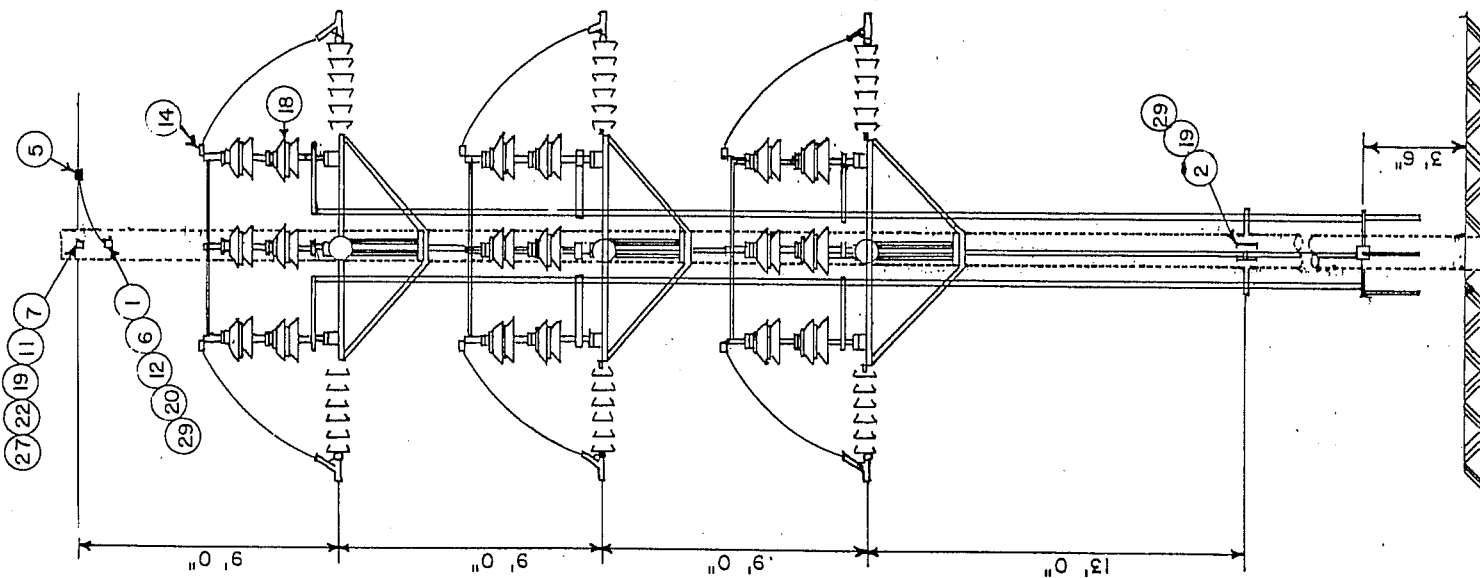

| DATE | REVISION | BY |
|---------|----------|-----|
| 7/17/67 | REDRAWN | WJK |
| | | |
| | | |

EAST RIVER ELECTRIC POWER COOPERATIVE, INC.
 MADISON, S. DAKOTA

TM-33A

| | | | |
|----------|----------|----------|---------|
| DATE | DWG. NO. | SCALE | NTS |
| 8/7/1968 | 899 | | |
| W.O. NO. | | SHEET | OF |
| | | | |
| DWN. BY | WHK | DWN. FOR | EXP. BY |
| | | | |

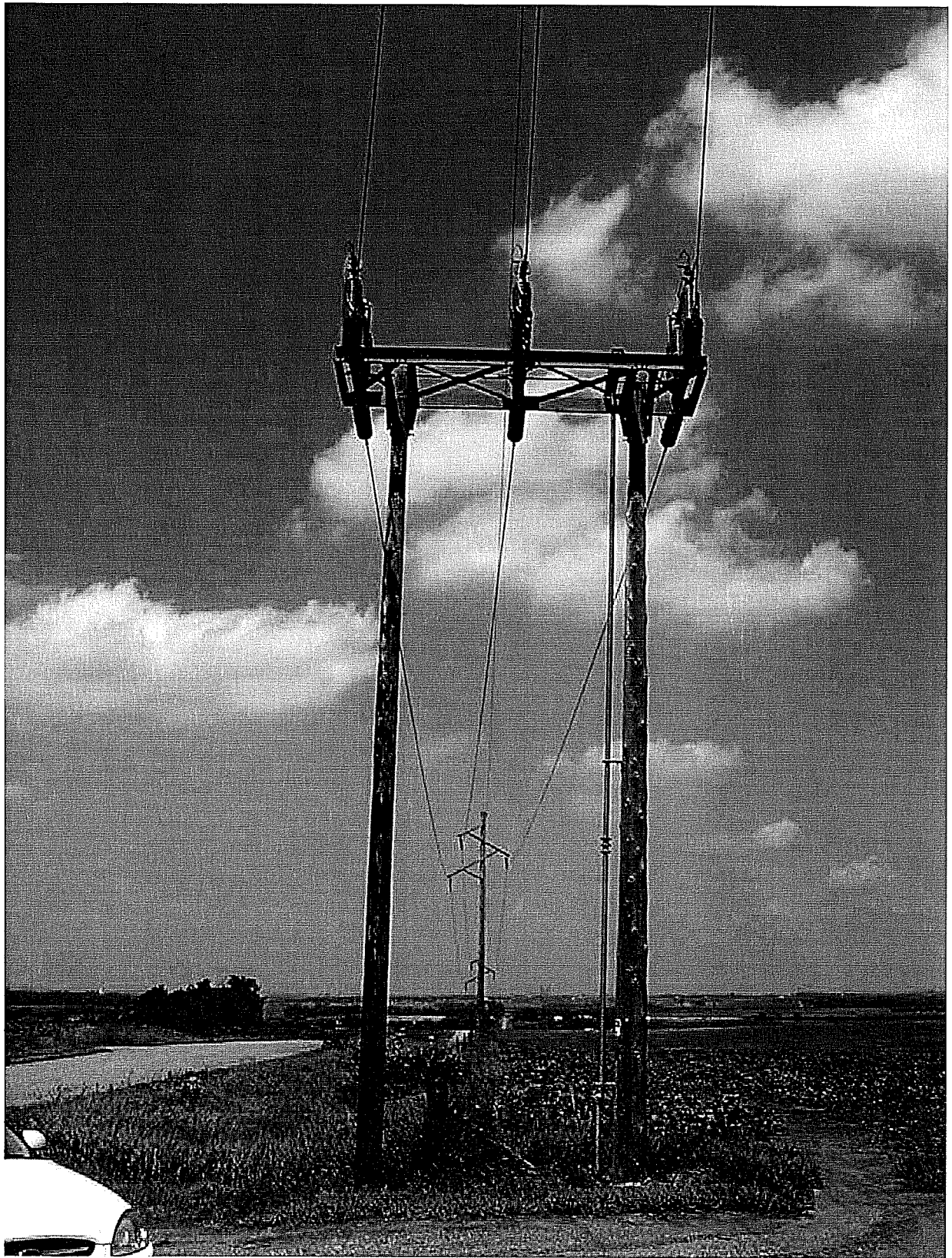

69 kV Line Switch

Exhibit 22

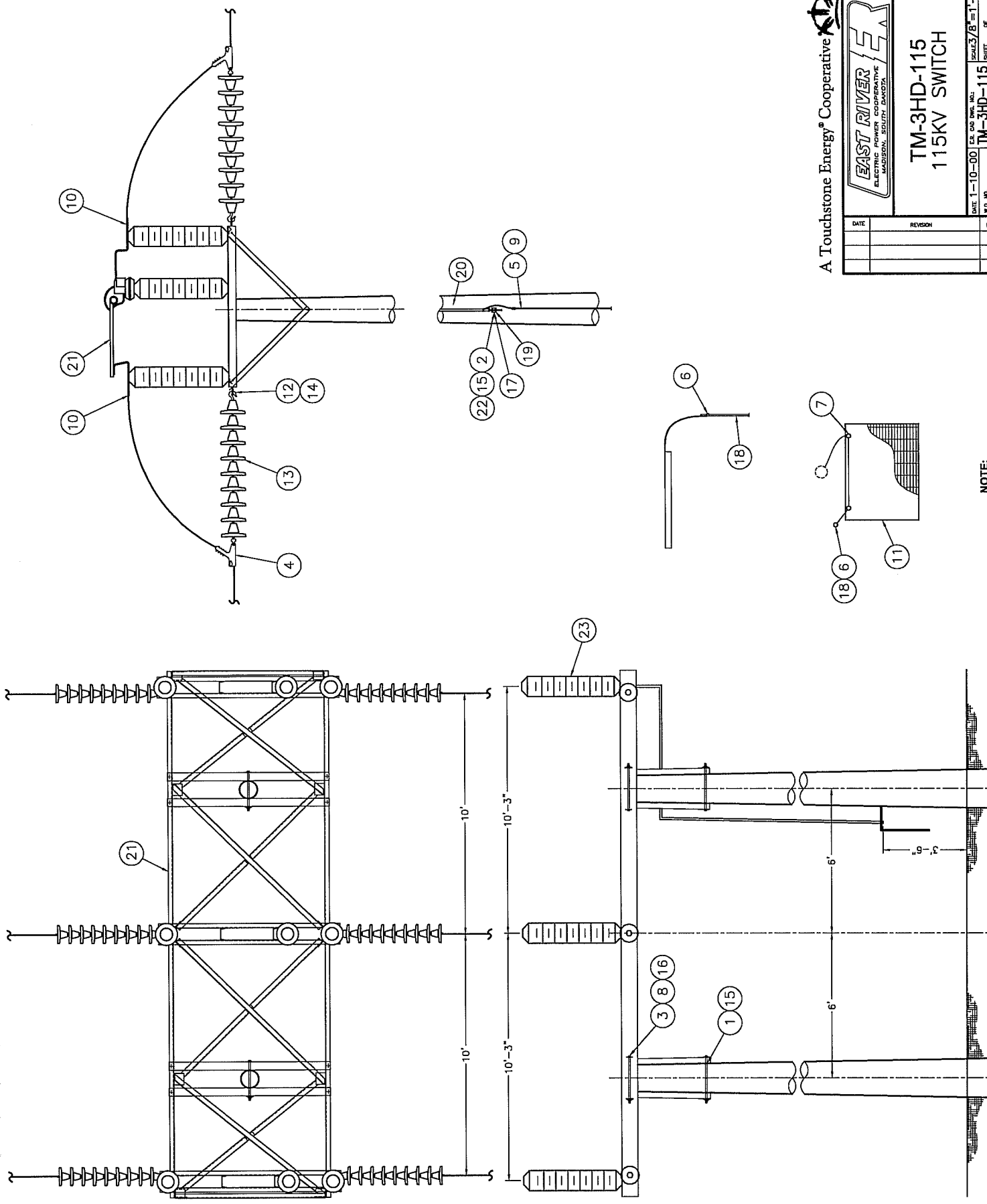

A Touchstone Energy Cooperative

EAST RIVER
ER
 ELECTRIC POWER COOPERATIVE
 MADISON, SOUTH DAKOTA

TM-3HD-115
 115KV SWITCH

| | |
|------|----------|
| DATE | REVISION |
| | |
| | |
| | |

DATE: 1-10-00
 E.R. CO. DWG. NO.:
 S.D. NO.:
 DWG. BY: D.J.Z.
 S.D. NO.:
 E.R. CO. DWG. NO.: TM-3HD-115
 SHEET 3/8 OF 1-0
 PROJECT: ERYPT
 SHEET 3 OF 1

NOTE:
 SCALE GIVEN IS FOR PAPER SIZE (17x22)

South Dakota Public Utilities Commission
WEEKLY FILINGS
For the Period of February 26, 2004 through March 3, 2004

If you need a complete copy of a filing faxed, overnight expressed, or mailed to you, please contact
Delaine Kolbo within five business days of this report. Phone: 605-773-3201

ELECTRIC

EL04-006 In the Matter of the Filing by Otter Tail Power Company for Approval of Tariff Revisions.

Application by Otter Tail Power Company (Otter Tail) for approval to revise its tariffed Summary List of Contracts with Deviations. The existing contract with the City of Hetland will expire on April 1, 2004. Otter Tail states the new agreement does not contain any deviations from Otter Tail's currently filed tariff and therefore requests that reference to a contract with the City of Hetland be removed from the Summary List of Contracts with Deviations.

Staff Analyst: Dave Jacobson
Staff Attorney: Karen Cremer
Date Filed: 02/26/04
Intervention Deadline: 03/19/04

EL04-007 In the Matter of the Filing by Otter Tail Power Company for Approval of Tariff Revisions.

Application by Otter Tail Power Company (Otter Tail) for approval to revise its tariffed Summary List of Contracts with Deviations. The existing contract with the City of Lake Preston will expire on April 1, 2004. Otter Tail states the new agreement does not contain any deviations from Otter Tail's currently filed tariff and therefore requests that reference to a contract with the City of Lake Preston be removed from the Summary List of Contracts with Deviations.

Staff Analyst: Dave Jacobson
Staff Attorney: Karen Cremer
Date Filed: 02/26/04
Intervention Deadline: 03/19/04

EL04-008 In the Matter of the Filing by Otter Tail Power Company for Approval of Tariff Revisions.

Application by Otter Tail Power Company (Otter Tail) for approval to revise its tariffed Summary List of Contracts with Deviations. The existing contract with the City of Trent will expire on April 1, 2004. Otter Tail states the new agreement does not contain any deviations from Otter Tail's currently filed tariff and therefore requests that reference to a contract with the City of Trent be removed from the Summary List of Contracts with Deviations.

Staff Analyst: Dave Jacobson
Staff Attorney: Karen Cremer
Date Filed: 02/26/04
Intervention Deadline: 03/19/04

EL04-009 In the Matter of the Application of East River Electric Power Cooperative, Inc. for a Transmission Upgrade to the Sioux Falls Area 115 kV Transmission Project.

On February 27, 2004, East River Electric Power Cooperative filed for approval an application for its proposed Sioux Falls Area 115 kilovolt Transmission Upgrade Project. The proposed project would convert approximately 36 miles of an existing East River 69 kilovolt transmission line and 7 existing East River 69 kilovolt distribution substations to 115 kilovolts. The project is needed for East River to be able to continue to adequately and reliably serve the growing electrical needs of its member distribution systems in the Sioux Falls area.

Staff Analyst: Michele Farris
Staff Attorney: Karen Cremer
Date Filed: 02/27/04
Intervention Deadline: 03/19/04

TELECOMMUNICATIONS

TC04-039 In the Matter of the Request of Qwest Corporation for Certification Regarding its Use of Federal Universal Service Support.

On February 27, 2004, Qwest Corporation (Qwest) provided information constituting Qwest's plan for the use of its federal universal service support and to otherwise verify that Qwest will use all federal universal service support received in a manner that is consistent with the federal universal service provisions of 47 U.S.C. Section 254.

Staff Analyst: Harlan Best
Staff Attorney: Karen Cremer
Date Docketed: 02/27/04
Intervention Deadline: 03/19/04

TC04-040 In the Matter of the Joint Application of Sioux Valley Telephone Company and Hills Telephone Company, Inc. Regarding the Sale by Sioux Valley Telephone Company of its Valley Springs, East Valley Springs and North Larchwood Exchanges to Hills Telephone Company, Inc.

On March 2, 2004, Hills Telephone Company, Inc. (Hills) and Sioux Valley Telephone Company (Sioux Valley) filed a joint application for the sale of the local telephone exchange facilities serving the Valley Springs, East Valley Springs, and North Larchwood local exchanges from Sioux Valley to Hills.

Staff Analyst: Harlan Best
Staff Attorney: Karen Cremer
Date Docketed: 03/02/04
Intervention Deadline: 03/19/04

You may receive this listing and other PUC publications via our website or via internet e-mail. You may subscribe or unsubscribe to the PUC mailing lists at <http://www.state.sd.us/puc>

LAW OFFICES
MAY, ADAM, GERDES & THOMPSON LLP
503 SOUTH PIERRE STREET
P.O. BOX 160
PIERRE, SOUTH DAKOTA 57501-0160

THOMAS C. ADAM
DAVID A. GERDES
CHARLES M. THOMPSON
ROBERT B. ANDERSON
BRENT A. WILBUR
TIMOTHY M. ENGEL
MICHAEL F. SHAW
NEIL FULTON
BRETT KOENECKE

SINCE 1881
www.magt.com

OF COUNSEL
WARREN W. MAY
GLENN W. MARTENS 1881-1963
KARL GOLDSMITH 1885-1966

TELEPHONE
605 224-8803

TELECOPIER
605 224-6289

March 19, 2004

e-mail
koenecke@magt.com

Pam Bonrud
Executive Secretary
Public Utilities Commission
500 East Capitol Avenue
Pierre, SD 57501

RECEIVED

MAR 19 2004

SOUTH DAKOTA PUBLIC
UTILITIES COMMISSION

RE: ELO4-009
Our file: 0185

Dear Pam:

Enclosed for filing please find and original and eleven copies of Xcel Energy's Motion to Intervene in the above referenced matter. By copy of this letter service is made on Jim Edwards, Assistant General Manager, Operations, East River Electric Power Cooperative, PO Box 227, Madison, SD 57042, and David Blair, East River Electric Power Cooperative, PO Box 227, Madison, SD 57042.

Very truly yours.

MAY, ADAM, GERDES & THOMPSON LLP



BRETT M. KOENECKE

BMK:njh

Enclosure

cc: Jim Edwards
David Blair
Jim Wilcox

RECEIVED

BEFORE THE PUBLIC UTILITIES COMMISSION
OF THE STATE OF SOUTH DAKOTA

MAR 19 2004

SOUTH DAKOTA PUBLIC
UTILITIES COMMISSION

IN THE MATTER OF THE APPLICATION)
OF EAST RIVER ELECTRIC POWER)
COOPERATIVE, INC., FOR A TRANSMISSION)
UPGRADE TO THE SIOUX FALLS AREA,)
115 KV TRANSMISSION UPGRADE PROJECT)

DOCKET EL041009

MOTION TO INTERVENE

COMES NOW Xcel Energy, Inc., by and through its attorneys and moves the Commission for leave to intervene in the above captioned docket.

In support of its Motion, Petitioner states that it has a pecuniary interest in the matter at hand as it is currently serving the Sioux Falls, South Dakota, area as and within its assigned territory. The project by East River will necessarily involve construction and upgrading of numerous electrical facilities in and around the area served by Xcel Energy. Xcel wishes to become a party to this docket to insure that it receives all filings on the subject, and remains knowledgeable and aware on the project.

WHEREAS the Movant requests that the Commission make its order granting intervention to Xcel Energy, Inc.

Dated this 19 day of March, 2004.

MAY, ADAM, GERDES & THOMPSON LLP

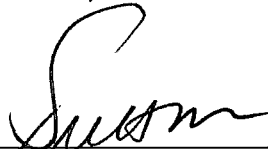
BY:  _____

BRETT M. KOENECKE
Attorneys for Xcel Energy
503 S. Pierre Street
PO Box 160
Pierre, South Dakota 57501-0160
(605) 224-8803

CERTIFICATE OF SERVICE

19 Brett Koenecke of May, Adam, Gerdes & Thompson LLP, hereby certifies that on the day of March, 2004, he mailed by United States mail, first class postage thereon prepaid, a true and correct copy of the foregoing in the above-captioned action to the following at his last known address, to-wit:

Jim Edwards
Assistant General Manager, Operations
East River Electric Power Cooperative
121 Southeast First Street
PO Box 227
Madison, SD 57042

David Blair
East River Electric Power Cooperative
121 Southeast First Street
PO Box 227
Madison, SD 57042



Brett Koenecke

**BEFORE THE PUBLIC UTILITIES COMMISSION
OF THE STATE OF SOUTH DAKOTA**

| | | |
|---|---|-------------------------------|
| IN THE MATTER OF THE APPLICATION OF |) | NOTICE OF APPLICATION; |
| EAST RIVER ELECTRIC POWER |) | ORDER FOR AND NOTICE |
| COOPERATIVE, INC. FOR A TRANSMISSION |) | OF PUBLIC INPUT |
| UPGRADE TO THE SIOUX FALLS AREA 115 |) | HEARING; NOTICE OF |
| KV TRANSMISSION PROJECT |) | OPPORTUNITY TO APPLY |
| |) | FOR PARTY STATUS |
| |) | EL04-009 |

On February 27, 2004, East River Electric Power Cooperative, Inc. (East River) submitted to the Public Utilities Commission (Commission) an application for its proposed Sioux Falls Area 115 kilovolt (kV) transmission upgrade project. The application states that the proposed project would upgrade approximately 36 miles of an existing 69 kV transmission line and 7 existing 69 kV distribution substations to 115 kV to enable East River to continue to adequately and reliably serve the growing demand for electric service of its member distribution systems in the Sioux Falls area. The line and substation facilities to be upgraded are located in Lincoln and Minnehaha Counties, beginning at WAPA's Sioux Falls Substation on Rice Street and 478 Ave. (east of Great Bear), extending east to the West Brandon Substation on Holly Blvd. west of Brandon, then north and east to the Brandon and Corson Substations on Splitrock Blvd. on the north side of Brandon and east of Corson, respectively, then east on Redwood Blvd. and south on Chestnut Ave. to the Rowena Substation north of Rowena, then south and east to the Splitrock Substation on Highway 42 east of Sioux Falls, then south to the Harrisburg Substation west of Highway 11 (one mile south of the Harrisburg corner), then east to the Tea Substation two miles south of Tea. On March 19, 2004, Xcel Energy, Inc. (Xcel) filed a Motion to Intervene, which motion included a request to receive all filings in the docket.

The Commission asserts jurisdiction over this matter pursuant to SDCL Chapter 49-41B, specifically 49-41B-1, 49-41B-2, 49-41B-2.1, 49-41B-4, 49-41B-11, 49-41B-12, 49-41B-13, 49-41B-15, 49-41B-16, 49-41B-17, 49-41B-17.1, 49-41B-21, 49-41B-22, 49-41B-25, 49-41B-26, 49-41B-33, 49-41B-38, and ARSD Chapter 20:10:22.

Pursuant to SDCL 49-41B-15 and 49-41B-16, the Commission will hold a public hearing on East River's application on Monday, April 12, 2004, at 8:00 p.m. CDT in the Meeting Room of the Ronning Branch Library, 3100 E. 49th St. (east of Southeastern on 49th St.), Sioux Falls, SD. The purpose of the hearing will be to hear public comment regarding East River's application. At the public input hearing, East River will present a brief description of the project, following which interested persons may appear and present their views, comments and questions regarding the application. A copy of the application is on file with the Minnehaha and Lincoln County Auditors pursuant to SDCL 49-41B-15(5) and the Commission's office in Pierre.

Pursuant to SDCL 49-41B-17 and ARSD 20:10:22:40, the parties to this proceeding are currently East River and the Commission. Xcel has filed a motion to intervene and a request to receive all filings in the case. Further, each municipality, county, and governmental agency in the area where the facility is proposed to be sited; any non-profit organization, formed in whole or in part to promote conservation or natural beauty, to protect the environment, personal health or other biological values, to preserve historical sites, to promote consumer interests, to represent commercial and industrial groups, or to promote the orderly development of the area in which the facility is to be sited; or any interested person, may be granted party status in this proceeding by making written application to the Commission.

Following the public input hearing, the Commission may schedule one or more subsequent formal evidentiary hearings conforming to SDCL 1-26 to consider any issues raised by any intervening party, Commission Staff or the Commission itself. At such formal hearing, all parties will have the opportunity to appear and present evidence and cross-examination of the other parties' witnesses and exercise all other rights afforded by SDCL 1-26, 49-1 and 49-41B and ARSD 20:10:01 and 20:10:22. Absent a contested issue, the Commission will schedule the matter for decision at a regular or special meeting of the Commission.

For approval, East River must show that the proposed transmission upgrade project will comply with all applicable laws and rules, will not pose a threat of serious injury to the environment nor to the social and economic condition of inhabitants or expected inhabitants in the siting area, will not substantially impair the health, safety or welfare of the inhabitants, and will not unduly interfere with the orderly development of the region with due consideration having been given to the views of governing bodies of affected local units of government. The Commission will decide whether the permit should be granted, denied or granted upon such terms, conditions or modifications of the construction, operation or maintenance as the Commission finds appropriate.

It is therefore

ORDERED, that the Commission will hold a public input hearing on Monday, April 12, 2004, at 8:00 p.m. CDT, in the Meeting Room of the Ronning Branch Library, 3100 E. 49th St. (east of Southeastern on 49th St.), Sioux Falls, SD; and it is

FURTHER ORDERED, that pursuant to SDCL 49-41B-17 and ARSD 20:10:22:40, applications for party status must be filed on or before April 27, 2004; and it is

FURTHER ORDERED, that pursuant to SDCL 49-41B-17.1, a party who wishes to receive personal service of all material filed in this matter shall make a specific request to the Commission for personal service, which may be included in the application for party status. Absent such a specific request, the County Auditors for Minnehaha and Lincoln

Counties are designated by law as the agents for service of process upon all parties to this proceeding residing in Minnehaha and Lincoln Counties, respectively.

Pursuant to the Americans with Disabilities Act, this hearing is being held in a physically accessible location. Please contact the Public Utilities Commission at 1-800-332-1782 at least 48 hours prior to the hearing if you have special needs so arrangements can be made to accommodate you.

Dated at Pierre, South Dakota, this 25th day of March, 2004.

| | |
|--|---------------------|
| CERTIFICATE OF SERVICE | |
| The undersigned hereby certifies that this document has been served today upon all parties of record in this docket, as listed on the docket service list, by facsimile or by first class mail, in properly addressed envelopes, with charges prepaid thereon. | |
| By: | <u>Tina Douglas</u> |
| Date: | <u>3-25-04</u> |
| (OFFICIAL SEAL) | |

BY ORDER OF THE COMMISSION:

Robert K. Sahr
ROBERT K. SAHR, Chairman

Gary Hanson
GARY HANSON, Commissioner

James A. Burg
JAMES A. BURG, Commissioner

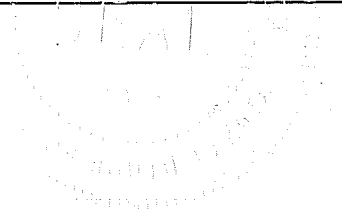

**BEFORE THE PUBLIC UTILITIES COMMISSION
OF THE STATE OF SOUTH DAKOTA**

| | | |
|---|---|---------------------------------|
| IN THE MATTER OF THE APPLICATION OF |) | <u>AMENDED</u> NOTICE OF |
| EAST RIVER ELECTRIC POWER |) | APPLICATION; ORDER FOR |
| COOPERATIVE, INC. FOR A TRANSMISSION |) | AND NOTICE OF PUBLIC |
| UPGRADE TO THE SIOUX FALLS AREA 115 |) | INPUT HEARING; NOTICE |
| KV TRANSMISSION PROJECT |) | OF OPPORTUNITY TO |
| |) | APPLY FOR PARTY STATUS |
| |) | EL04-009 |

On February 27, 2004, East River Electric Power Cooperative, Inc. (East River) submitted to the Public Utilities Commission (Commission) an application for its proposed Sioux Falls Area 115 kilovolt (kV) transmission upgrade project. The application states that the proposed project would upgrade approximately 36 miles of an existing 69 kV transmission line and 7 existing 69 kV distribution substations to 115 kV to enable East River to continue to adequately and reliably serve the growing demand for electric service of its member distribution systems in the Sioux Falls area. The line and substation facilities to be upgraded are located in Lincoln and Minnehaha Counties, beginning at WAPA's Sioux Falls Substation on Rice Street and 478 Ave. (east of Great Bear), extending east to the West Brandon Substation on Holly Blvd. west of Brandon, then north and east to the Brandon and Corson Substations on Splitrock Blvd. on the north side of Brandon and east of Corson, respectively, then east on Redwood Blvd. and south on Chestnut Ave. to the Rowena Substation north of Rowena, then south and east to the Splitrock Substation on Highway 42 east of Sioux Falls, then south to the Harrisburg Substation west of Highway 11 (one mile south of the Harrisburg corner), then east to the Tea Substation two miles south of Tea. On March 19, 2004, Xcel Energy, Inc. (Xcel) filed a Motion to Intervene, which motion included a request to receive all filings in the docket.

The Commission asserts jurisdiction over this matter pursuant to SDCL Chapter 49-41B, specifically 49-41B-1, 49-41B-2, 49-41B-2.1, 49-41B-4, 49-41B-11, 49-41B-12, 49-41B-13, 49-41B-15, 49-41B-16, 49-41B-17, 49-41B-17.1, 49-41B-21, 49-41B-22, 49-41B-25, 49-41B-26, 49-41B-33, 49-41B-38, and ARSD Chapter 20:10:22.

Pursuant to SDCL 49-41B-15 and 49-41B-16, the Commission will hold a public hearing on East River's application on Monday, April 12, 2004, at ~~8:00~~ 7:00 p.m. CDT in the Meeting Room of the Ronning Branch Library, 3100 E. 49th St. (east of Southeastern on 49th St.), Sioux Falls, SD. The purpose of the hearing will be to hear public comment regarding East River's application. At the public input hearing, East River will present a brief description of the project, following which interested persons may appear and present their views, comments and questions regarding the application. A copy of the application is on file with the Minnehaha and Lincoln County Auditors pursuant to SDCL 49-41B-15(5) and the Commission's office in Pierre.

Pursuant to SDCL 49-41B-17 and ARSD 20:10:22:40, the parties to this proceeding are currently East River and the Commission. Xcel has filed a motion to intervene and a request to receive all filings in the case. Further, each municipality, county, and governmental agency in the area where the facility is proposed to be sited; any non-profit organization, formed in whole or in part to promote conservation or natural beauty, to protect the environment, personal health or other biological values, to preserve historical sites, to promote consumer interests, to represent commercial and industrial groups, or to promote the orderly development of the area in which the facility is to be sited; or any interested person, may be granted party status in this proceeding by making written application to the Commission.

Following the public input hearing, the Commission may schedule one or more subsequent formal evidentiary hearings conforming to SDCL 1-26 to consider any issues raised by any intervening party, Commission Staff or the Commission itself. At such formal hearing, all parties will have the opportunity to appear and present evidence and cross-examination of the other parties' witnesses and exercise all other rights afforded by SDCL 1-26, 49-1 and 49-41B and ARSD 20:10:01 and 20:10:22. Absent a contested issue, the Commission will schedule the matter for decision at a regular or special meeting of the Commission.

For approval, East River must show that the proposed transmission upgrade project will comply with all applicable laws and rules, will not pose a threat of serious injury to the environment nor to the social and economic condition of inhabitants or expected inhabitants in the siting area, will not substantially impair the health, safety or welfare of the inhabitants, and will not unduly interfere with the orderly development of the region with due consideration having been given to the views of governing bodies of affected local units of government. The Commission will decide whether the permit should be granted, denied or granted upon such terms, conditions or modifications of the construction, operation or maintenance as the Commission finds appropriate.

It is therefore

ORDERED, that the Commission will hold a public input hearing on Monday, April 12, 2004, at ~~8:00~~ 7:00 p.m. CDT, in the Meeting Room of the Ronning Branch Library, 3100 E. 49th St. (east of Southeastern on 49th St.), Sioux Falls, SD; and it is

FURTHER ORDERED, that pursuant to SDCL 49-41B-17 and ARSD 20:10:22:40, applications for party status must be filed on or before April 27, 2004; and it is

FURTHER ORDERED, that pursuant to SDCL 49-41B-17.1, a party who wishes to receive personal service of all material filed in this matter shall make a specific request to the Commission for personal service, which may be included in the application for party status. Absent such a specific request, the County Auditors for Minnehaha and Lincoln

Counties are designated by law as the agents for service of process upon all parties to this proceeding residing in Minnehaha and Lincoln Counties, respectively.

Pursuant to the Americans with Disabilities Act, this hearing is being held in a physically accessible location. Please contact the Public Utilities Commission at 1-800-332-1782 at least 48 hours prior to the hearing if you have special needs so arrangements can be made to accommodate you.

Dated at Pierre, South Dakota, this 5th day of April, 2004.

| | |
|--|---------------------|
| CERTIFICATE OF SERVICE | |
| The undersigned hereby certifies that this document has been served today upon all parties of record in this docket, as listed on the docket service list, by facsimile or by first class mail, in properly addressed envelopes, with charges prepaid thereon. | |
| By: | <u>Alaine Kolbo</u> |
| Date: | <u>4/6/04</u> |
| (OFFICIAL SEAL) | |

BY ORDER OF THE COMMISSION:

Robert K. Sahr

ROBERT K. SAHR, Chairman

Gary Hanson

GARY HANSON, Commissioner

James A. Burg

JAMES A. BURG, Commissioner

JAMES ZWEEP, CHAIRMAN
MINNEHAHA COUNTY COMMISSION
3244 S GRACE AVENUE
SIOUX FALLS SD 57110

OTTO HAGEDORN, CHAIRMAN
LINCOLN COUNTY COMMISSION
46954 272ND STREET
TEA SD 57064

Delaine this who I mailed
to beside the envelope
you did for me
Mail 3-25-04

MS. SUE ROUST
MINNEHAHA COUNTY AUDITOR
415 N DAKOTA AVENUE
SIOUX FALLS SD 57104-2465

MS. PAULA FEUCHT
LINCOLN COUNTY AUDITOR
100 E. 5TH STREET
CANTON SD 57013

MAYOR JOHN LAWLER
PO BOX 128
TEA SD 57064-0128

MAYOR DAVE MUNSON
224 W 9TH STREET
SIOUX FALLS SD 57104-6407

MAYOR LARRY BEESLEY
PO BOX 95
BRANDON SD 57005-0095

MAYOR JAMES AALBERS
PO BOX 26
HARRISBURG SD 57032-0026



Bob Sahr, Chair
Gary Hanson, Vice-Chair
Jim Burg, Commissioner

SOUTH DAKOTA PUBLIC UTILITIES COMMISSION

500 East Capitol Avenue
Pierre, South Dakota 57501-5070
www.state.sd.us/puc

Capitol Office
(605) 773-3201
(605) 773-3809 fax

Transportation/Warehouse
(605) 773-5280
(605) 773-3225 fax

Consumer Hotline
1-800-332-1782

March 31, 2004

mailed + faxed

The Argus Leader
Display Advertising Department
P. O. Box 5034
Sioux Falls, SD 57117-5034

*Changed ad
to 7 P.M.*

Re: In the Matter of the Application of East River Electric
Power Cooperative, Inc. for a Transmission Upgrade
to the Sioux Falls Area 115 kV Transmission Project
Docket EL04-009

To whom it may concern:

Enclosed you will find Notice of Public Hearing for a Proposed Transmission Upgrade with reference to the above captioned matter. Please publish the enclosed Notice in your paper as a display advertisement for one issue by April 7, 2004.

Please send us your Affidavit of Publication and invoice as soon as possible. Thank you.

Very truly yours,

John Smith
Commission Counsel

JS:dk
Enc.



Bob Sahr, Chair
Gary Hanson, Vice-Chair
Jim Burg, Commissioner

SOUTH DAKOTA PUBLIC UTILITIES COMMISSION

500 East Capitol Avenue
Pierre, South Dakota 57501-5070
www.state.sd.us/puc

Capitol Office
(605) 773-3201
(605) 773-3809 fax

Transportation/Warehouse
(605) 773-5280
(605) 773-3225 fax

Consumer Hotline
1-800-332-1782

March 31, 2004

e-mail: tribune@dellrapids.net

Brandon Valley Resident
Attention: Andrea
P. O. Box 257
Brandon, SD 57005-0257

Re: In the Matter of the Application of East River Electric
Power Cooperative, Inc. for a Transmission Upgrade
to the Sioux Falls Area 115 kV Transmission Project
Docket EL04-009

To Andrea:

Enclosed you will find Notice of Public Hearing for a Proposed Transmission Upgrade with reference to the above captioned matter. Please publish the enclosed Notice in your paper as a display advertisement for one issue by April 7, 2004.

Please send us your Affidavit of Publication and invoice as soon as possible. Thank you.

Very truly yours,

John Smith
Commission Counsel

JS:dk
Enc.



Bob Sahr, Chair
Gary Hanson, Vice-Chair
Jim Burg, Commissioner

SOUTH DAKOTA PUBLIC UTILITIES COMMISSION

500 East Capitol Avenue
Pierre, South Dakota 57501-5070
www.state.sd.us/puc

Capitol Office
(605) 773-3201
(605) 773-3809 fax

Transportation/Warehouse
(605) 773-5280
(605) 773-3225 fax

Consumer Hotline
1-800-332-1782

March 31, 2004

e-mail: nwebb@argusleader.com

Tea and Harrisburg Champion
P. O. Box 214
Tea, SD 57064-0214

Re: In the Matter of the Application of East River Electric
Power Cooperative, Inc. for a Transmission Upgrade
to the Sioux Falls Area 115 kV Transmission Project
Docket EL04-009

To whom it may concern:

Enclosed you will find Notice of Public Hearing for a Proposed Transmission Upgrade with reference to the above captioned matter. Please publish the enclosed Notice in your paper as a display advertisement for one issue by April 7, 2004.

Please send us your Affidavit of Publication and invoice as soon as possible. Thank you.

Very truly yours,

John Smith
Commission Counsel

JS:dk
Enc.

**NOTICE OF PUBLIC HEARING
SOUTH DAKOTA PUBLIC UTILITIES COMMISSION
PROPOSED EAST RIVER ELECTRIC COOPERATIVE
SIOUX FALLS AREA TRANSMISSION UPGRADE PROJECT**

WHEN: Monday, April 12, 2004 at 8:00 p.m. CDT

WHERE: Meeting Room, Ronning Branch Library, 3100 E. 49th St. (east of Southeastern on 49th St.), Sioux Falls, SD

Pursuant to SDCL 49-41B-15 and 49-41B-16, the South Dakota Public Utilities Commission (Commission) will hold a public input hearing at the above time and place on an application filed by East River Electric Power Cooperative, Inc. (East River) for its proposed Sioux Falls area 115 kilovolt (kV) transmission upgrade project. The application states that the proposed project would upgrade approximately 36 miles of an existing 69 kV transmission line and 7 existing 69 kV distribution substations to 115 kV to enable East River to continue to adequately and reliably serve the growing demand for electric service of its member distribution systems in the Sioux Falls area. The line and substation facilities to be upgraded are located in Lincoln and Minnehaha Counties, beginning at WAPA's Sioux Falls Substation on Rice Street and 478 Ave. (east of Great Bear), extending east to the West Brandon Substation on Holly Blvd. west of Brandon, then north and east to the Brandon and Corson Substations on Splitrock Blvd. on the north side of Brandon and east of Corson, respectively, then east on Redwood Blvd. and south on Chestnut Ave. to the Rowena Substation north of Rowena, then south and east to the Splitrock Substation on Highway 42 east of Sioux Falls, then south to the Harrisburg Substation west of Highway 11 (one mile south of the Harrisburg corner), then east to the Tea Substation two miles south of Tea.

At the hearing, interested persons may appear and present their questions, views and comments regarding the application. The application is on file with the Minnehaha and Lincoln County Auditors pursuant to SDCL 49-41B-15(5) and in the Commission's office in Pierre.

The parties to this proceeding are currently East River and the Commission. Xcel Energy, Inc. has filed a motion to intervene. Pursuant to SDCL 49-41B-17, any person residing in the area of the project, each municipality, county, and governmental agency in the project area, any non-profit organization formed in whole or in part to promote conservation or natural beauty, to protect the environment, personal health or other biological values, to preserve historical sites, to promote consumer interests, to represent commercial and industrial groups, or to promote the orderly development of the project area, or any interested person, may be granted formal party status in this proceeding by making written application to the Commission as provided in ARSD 20:10:22:40 on or before April 27, 2004.

For approval, East River must show that the proposed transmission upgrade project will comply with all applicable laws and rules, will not pose a threat of serious injury to the environment nor to the social and economic condition of inhabitants or expected inhabitants in the siting area, will not substantially impair the health, safety or welfare of the inhabitants, and will not unduly interfere with the orderly development of the region with due consideration having been given to the views of governing bodies of affected local units of government. The Commission will decide whether the permit should be granted, denied or granted upon such terms, conditions or modifications of the construction, operation or maintenance as the Commission finds appropriate.

Pursuant to the Americans with Disabilities Act, this hearing is being held in a physically accessible location. Please contact the Commission at least 48 hours prior to the hearing if you have special needs so arrangements can be made to accommodate you. The Commission's contact information is: ph (800) 332-1782; fax (605) 773-3809; www.state.sd.us/puc; 500 E. Capitol Ave., Pierre, SD 57105. The formal Order for and Notice of Hearing and the Commission's administrative rules (ARSD 20:10) may be accessed on the web site.

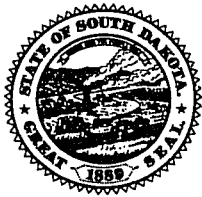

Bob Sahr, Chair
Gary Hanson, Vice-Chair
Jim Burg, Commissioner

SOUTH DAKOTA PUBLIC UTILITIES COMMISSION

500 East Capitol Avenue
Pierre, South Dakota 57501-5070
www.state.sd.us/puc

Capitol Office
(605) 773-3201
(605) 773-3809 fax

Transportation/Warehouse
(605) 773-5280
(605) 773-3225 fax

Consumer Hotline
1-800-332-1782

FACSIMILE TRANSMISSION

April 1, 2004

**TO: Thea
The Argus Leader**

FAX#: 605-331-2371

**FROM: Delaine Kolbo
South Dakota Public Utilities Commission
Fax: 605-773-3809**

This is page 1 of 6

These are the two notices I faxed yesterday. Thank you for taking care of this for me.

If there is a problem receiving this document, please contact our office at (605) 773-3201.

THIS COMMUNICATION IS INTENDED ONLY FOR THE USE OF THE INDIVIDUAL OR ENTITY TO WHICH IT IS ADDRESSED AND MAY CONTAIN INFORMATION THAT IS PRIVILEGED, CONFIDENTIAL AND EXEMPT FROM DISCLOSURE UNDER APPLICABLE LAW.

If the reader of this message is not the intended recipient or the employee or agent responsible for delivering this communication to the intended recipient, you are hereby notified that any distribution, use or copying of this communication is prohibited.

If you received this communication in error, please notify us immediately at (605) 773-3201.

**BEFORE THE PUBLIC UTILITIES COMMISSION
OF THE STATE OF SOUTH DAKOTA**

| | |
|---|-------------------------------|
| IN THE MATTER OF THE APPLICATION OF) | ORDER ASSESSING FILING |
| EAST RIVER ELECTRIC POWER) | FEE |
| COOPERATIVE, INC. FOR A TRANSMISSION) | |
| UPGRADE TO THE SIOUX FALLS AREA 115) | EL04-009 |
| KV TRANSMISSION PROJECT) | |

On February 27, 2004, East River Electric Power Cooperative, Inc. (East River) submitted to the Public Utilities Commission (Commission) an application for its proposed Sioux Falls Area 115 kilovolt (kV) transmission upgrade project. The application states that the proposed project would upgrade approximately 36 miles of an existing 69 kV transmission line and 7 existing 69 kV distribution substations to 115 kV to enable East River to continue to adequately and reliably serve the growing demand for electric service of its member distribution systems in the Sioux Falls area. The line and substation facilities to be upgraded are located in Lincoln and Minnehaha Counties, beginning at WAPA's Sioux Falls Substation on Rice Street and 478 Ave. (east of Great Bear), extending east to the West Brandon Substation on Holly Blvd. west of Brandon, then north and east to the Brandon and Corson Substations on Splitrock Blvd. on the north side of Brandon and east of Corson, respectively, then east on Redwood Blvd. and south on Chestnut Ave. to the Rowena Substation north of Rowena, then south and east to the Splitrock Substation on Highway 42 east of Sioux Falls, then south to the Harrisburg Substation west of Highway 11 (one mile south of the Harrisburg corner), then east to the Tea Substation two miles south of Tea. On March 19, 2004, Xcel Energy, Inc. (Xcel) filed a Motion to Intervene, which motion included a request to receive all filings in the docket.

On March 4, 2004, the Commission electronically transmitted notice of the filing and the intervention deadline of March 19, 2004, to interested individuals and entities.

SDCL 49-41B-12 authorizes the Commission to assess a maximum fee not to exceed one-quarter of one percent of the first one hundred million dollars of estimated construction costs of the facility. However, the minimum total fee chargeable may not be less than eight thousand dollars. The fee shall be deposited in the South Dakota Public Utilities Commission's (SDPUC) regulatory assessment fee fund to defray Commission expenses incident to analyzing and ruling upon this type of filing.

The Commission asserts jurisdiction over this matter pursuant to SDCL Chapter 49-41B, specifically 49-41B-1, 49-41B-2, 49-41B-2.1, 49-41B-4, 49-41B-11, 49-41B-12, 49-41B-13, 49-41B-15, 49-41B-16, 49-41B-17, 49-41B-17.1, 49-41B-21, 49-41B-22, 49-41B-25, 49-41B-26, 49-41B-33, 49-41B-38, and ARSD Chapter 20:10:22.

On March 23, 2004, at its regularly scheduled meeting, the Commission, pursuant to SDCL 49-41B-12, unanimously voted to assess East River a filing fee not to exceed \$17,250, with an initial deposit of \$8,000, the minimum fee allowed by law as requested by the Deputy Executive Director. It is therefore

ORDERED, that East River shall be assessed a filing fee of not to exceed \$17,250.00; and it is further

ORDERED, that East River shall make an initial deposit in the SDPUC regulatory assessment fee fund in the amount of the minimum filing fee of \$8,000 and shall from time to time make such additional deposits up to the total amount of the assessment as requested by the Deputy Executive Director.

Dated at Pierre, South Dakota, this 5th day of April, 2004.

| |
|---|
| <p style="text-align: center;">CERTIFICATE OF SERVICE</p> <p>The undersigned hereby certifies that this document has been served today upon all parties of record in this docket, as listed on the docket service list, by facsimile or by first class mail, in properly addressed envelopes, with charges prepaid thereon.</p> <p>By: <u><i>Hilaine Kalbs</i></u></p> <p>Date: <u>4/6/04</u></p> <p style="text-align: center;">(OFFICIAL SEAL)</p> |
|---|

BY ORDER OF THE COMMISSION:

Robert K. Sahr

ROBERT K. SAHR, Chairman

Gary Hanson

GARY HANSON, Commissioner

| | | | | |
|------------------|------------------------|---------------------|---|--|
| CUSTOMER NUMBER: | 44377 | Argus Leader | P.O. Box 5034, Sioux Falls, S.D. 57117-5034 | |
| INVOICE NUMBER: | | | | |
| RUN DATES: | Tuesday, April 6, 2004 | AMOUNT DUE | \$667.50 | |

SD PUBLIC UTILITIES
ATTN: JOHN SMITH
500 E CAPITOL AVE
PIERRE SD 57501-5070

RECEIVED

APR 09 2004

SOUTH DAKOTA PUBLIC UTILITIES COMMISSION

DETACH THIS STUB AND RETURN WITH PAYMENT

PAYMENT DUE UPON RECEIPT

AFFIDAVIT OF PUBLICATION-

AFFIDAVIT OF PUBLICATION

STATE OF SOUTH DAKOTA

COUNTY OF MINNEHAHA } ss

Beth Buchanan being duly sworn, says: That The Argus Leader is, and during all the times hereinafter mentioned was, a daily legal newspaper as defined by SDCL 17-2-21, as amended published at Sioux Falls, Minnehaha County, South Dakota; that affiant is and during all of said times, was an employee of the publisher of such newspaper and has personal knowledge of the facts stated in this affidavit; that the notice, order or advertisement, a printed copy of which is hereto attached, was published in said newspaper upon

Tuesday, the 6th day of April, 2004,
_____, the _____ day of _____, 2004,
_____, the _____ day of _____, 2004,
_____, the _____ day of _____, 2004,
_____, the _____ day of _____, 2004,
_____, the _____ day of _____, 2004,
_____, the _____ day of _____, 2004,

and that \$667.50 was charged for publishing the same for display advertising.

Beth Buchanan

Subscribed and sworn to before me April 6, 2004,

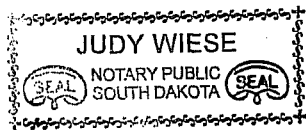

Judy Wiese
Notary Public, South Dakota

My Commission expires November 3, 2006

**NOTICE OF PUBLIC HEARING
SOUTH DAKOTA PUBLIC UTILITIES COMMISSION
PROPOSED EAST RIVER ELECTRIC COOPERATIVE
SIOUX FALLS AREA TRANSMISSION UPGRADE PROJECT**

WHEN: Monday, April 12, 2004 at 7:00 p.m. CDT

WHERE: Meeting Room, Ronning Branch Library, 3100 E. 49th St. (east of Southeastern on 49th St.),
Sioux Falls, SD

Pursuant to SDCL 49-41B-15 and 49-41B-16, the South Dakota Public Utilities Commission (Commission) will hold a public input hearing at the above time and place on an application filed by East River Electric Power Cooperative, Inc. (East River) for its proposed Sioux Falls area 115 kilovolt(kV) transmission upgrade project. The application states that the proposed project would upgrade approximately 36 miles of an existing 69 kV transmission line and 7 existing 69 kV distribution substations to 115 kV to enable East River to continue to adequately and reliably serve the growing demand for electric service of its member distribution systems in the Sioux Falls area. The line and substation facilities to be upgraded are located in Lincoln and Minnehaha Counties, beginning at WAPA's Sioux Falls Substation on Rice Street and 478 Ave. (east of Great Bear), extending east to the West Brandon Substation on Holly Blvd. west of Brandon, then north and east to the Brandon and Corson Substations on Splitrock Blvd. on the north side of Brandon and east of Corson, respectively, then east on Redwood Blvd. and south on Chestnut Ave. to the Rowena Substation north of Rowena, then south and east to the Splitrock Substation on Highway 42 east of Sioux Falls, then south to the Harrisburg Substation west of Highways 42 east of Sioux Falls, then south to the Harrisburg Substation west of Highway 11 (one mile south of the Harrisburg corner), then east to the Tea Substation two miles south of Tea.

A the hearing, interested persons may appear and present their questions, views and comments regarding the application. The application is on file with the Minnehaha and Lincoln County Auditors pursuant to SDCL 49-41B-15(5) and in the Commission's office in Pierre.

The parties to this proceeding are currently East River and the Commission. Xcel Energy, Inc. has filed a motion to intervene. Pursuant to SDCL 59-41B-17, any person residing in the area of the project, each municipality, county, and governmental agency in the project area, any non-profit organization formed in whole or in part to promote conservation or natural beauty, to protect the environment, personal health or other biological values, to preserve historical sites, to promote consumer interests, to represent commercial and industrial groups, or to promote the orderly development of the project area, or any interested person, may be granted formal party status in this proceeding by making written application to the Commission as provided in ARSD 20:10:22:40 on or before April 27, 2004.

For approval, East River must show that the proposed transmission upgrade project will comply with all applicable laws and rules, will not pose a threat of serious injury to the environment nor to the social and economic condition of inhabitants or expected inhabitants in the siting area, will not substantially impair the health, safety or welfare of the inhabitants, and will not unduly interfere with the orderly development of the region with due consideration have been given to the views of governing bodies of affected local units of government. The Commission will decide whether the permit should be granted, denied or granted upon such terms, conditions or modifications of the construction, operation or maintenance as the Commission finds appropriate.

Pursuant to the Americans with Disabilities Act, this hearing is being held in a physically accessible location. Please contact the Commission at least 48 hours prior to the hearing if you have special needs to arrangements can be made to accommodate you. The Commission's contact information is: ph (800) 332-1782; fax (605) 773-3809; www.state.sd.us/puc; 500 E. Capitol Ave., Pierre, SD 57105. The formal Order for and Notice of Hearing and the Commission's administrative rules (ARSD 20:10) may be accessed on the web site.

| | | |
|------------------|-----------|---|
| CUSTOMER NUMBER: | 127200 | Prairie Publications |
| INVOICE NUMBER: | PP9096 | |
| RUN DATES: | 4/7, 2004 | P.O. Box 5034, Sioux Falls, S.D. 57117-5034 |
| | | AMOUNT DUE: \$80.75 |

SD Public Utilities Commission
c/o John Smith
500 E Capitol Ave
Pierre, SD 57105

RECEIVED

APR 12 2004

DETACH THIS STUB AND RETURN WITH PAYMENT

SOUTH DAKOTA UTILITY PAYMENT DUE UPON RECEIPT

AFFIDAVIT OF PUBLICATION-

Customer Number: 127200
Invoice Number: PP9096

SD Public Utilities Commission

Prairie Publications
AFFIDAVIT OF PUBLICATION

STATE OF SOUTH DAKOTA

COUNTY OF MINNEHAHA } ss

Vicki Kiel being duly sworn, says: That the **Brandon Valley Challenger** is, and during all the times hereinafter mentioned was, a weekly legal newspaper as defined by SDCL 17-2-2.1 through 17-2-2.4, as amended published at Dell Rapids, Minnehaha County, South Dakota; that affiant is and during all of said times, was an employee of the publisher of such newspaper and has personal knowledge of the facts stated in this affidavit; that the notice, order or advertisement, a printed copy of which is hereto attached, was published in said newspaper upon

Wednesday, the 7 day of April 2004,
_____, the _____ day of _____ 2004,
_____, the _____ day of _____ 2004,
_____, the _____ day of _____ 2004,
_____, the _____ day of _____ 2004,

and that \$80.75 was charged for publishing the same

Vicki Kiel

Subscribed and sworn to before 4/9/2004.

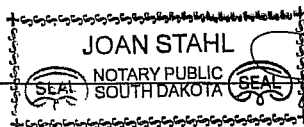

JOAN STAHL
NOTARY PUBLIC
SOUTH DAKOTA
Joan Stahl
Notary Public, South Dakota

My Commission expires June 30th, 2005

Notice

NOTICE OF PUBLIC HEARING SOUTH DAKOTA PUBLIC UTILITIES COMMISSION PROPOSED EAST RIVER ELECTRIC COOPERATIVE SIOUX FALLS AREA TRANSMISSION UPGRADE PROJECT

WHEN: Monday, April 12, 2004 at 7:00 p.m. CDT

WHERE: Meeting Room, Ronning Branch Library, 3100 E. 49th St. (east of Southeastern on 49th St.), Sioux Falls, SD

Pursuant to SDCL 49-41B-15 and 49-41B-16, the South Dakota Public Utilities Commission (Commission) will hold a public input hearing at the above time and place on an application filed by East River Electric Power Cooperative, Inc. (East River) for its proposed Sioux Falls area 115 kilovolt (kV) transmission upgrade project. The application states that the proposed project would upgrade approximately 36 miles of an existing 69 kV transmission line and 7 existing 69 kV distribution substations to 115 kV to enable East River to continue to adequately and reliably serve the growing demand for electric service of its member distribution systems in the Sioux Falls area. The line and substation facilities to be upgraded are located in Lincoln and Minnehaha Counties, beginning at WAPA's Sioux Falls Substation on Rice Street and 478 Ave. (east of Great Bear), extending east to the West Brandon Substation on Holly Blvd. west of Brandon, then north and east to the Brandon and Corson Substations on Splitrock Blvd. on the north side of Brandon and east of Corson, respectively, then east on Redwood Blvd. and south on Chestnut Ave. to the Rowena Substation north of Rowena, then south and east to the Splitrock Substation on Highway 42 east of Sioux Falls, then south to the Harrisburg Substation west of Highway 11 (one mile south of the Harrisburg corner), then east to the Tea Substation two miles south of Tea.

At the hearing, interested persons may appear and present their questions, views and comments regarding the application. The application is on file with the Minnehaha and Lincoln County Auditors pursuant to SDCL 49-41B-15(5) and in the Commission's office in Pierre.

The parties to this proceeding are currently East River and the Commission. Xcel Energy, Inc. has filed a motion to intervene. Pursuant to SDCL 49-41B-17, any person residing in the area of the project, each municipality, county, and governmental agency in the project area, any non-profit organization formed in whole or in part to promote conservation or natural beauty, to protect the environment, personal health or other biological values, to preserve historical sites, to promote consumer interests, to represent commercial and industrial groups, or to promote the orderly development of the project area, or any interested person, may be granted formal party status in this proceeding by making written application to the Commission as provided in ARSD 20:10:22:40 on or before April 27, 2004.

For approval, East River must show that the proposed transmission upgrade project will comply with all applicable laws and rules, will not pose a threat of serious injury to the environment nor to the social and economic condition of inhabitants or expected inhabitants in the siting area, will not substantially impair the health, safety or welfare of the inhabitants, and will not unduly interfere with the orderly development of the region with due consideration having been given to the views of governing bodies of affected local units of government. The Commission will decide whether the permit should be granted, denied or granted upon such terms, conditions or modifications of the construction, operation or maintenance as the Commission finds appropriate.

Pursuant to the Americans with Disabilities Act, this hearing is being held in a physically accessible location. Please contact the Commission at least 48 hours prior to the hearing if you have special needs so arrangements can be made to accommodate you. The Commission's contact information is: ph (800) 332-1782; fax (605) 773-3809; www.state.sd.us/puc; 500 E. Capitol Ave., Pierre, SD 57105. The formal Order for and Notice of Hearing and the Commission's administrative rules (ARSD 20:10) may be accessed on the web site.

PP9096

**BEFORE THE PUBLIC UTILITIES COMMISSION
OF THE STATE OF SOUTH DAKOTA**

| | |
|---|-----------------------|
| IN THE MATTER OF THE APPLICATION OF) | ORDER GRANTING |
| EAST RIVER ELECTRIC POWER) | INTERVENTION |
| COOPERATIVE, INC. FOR A TRANSMISSION) | |
| UPGRADE TO THE SIOUX FALLS AREA 115) | EL04-009 |
| KV TRANSMISSION PROJECT) | |

On February 27, 2004, East River Electric Power Cooperative, Inc. (East River) submitted to the Public Utilities Commission (Commission) an application for its proposed Sioux Falls Area 115 kilovolt (kV) transmission upgrade project. The application states that the proposed project would upgrade approximately 36 miles of an existing 69 kV transmission line and 7 existing 69 kV distribution substations to 115 kV to enable East River to continue to adequately and reliably serve the growing demand for electric service of its member distribution systems in the Sioux Falls area. The line and substation facilities to be upgraded are located in Lincoln and Minnehaha Counties, beginning at WAPA's Sioux Falls Substation on Rice Street and 478 Ave. (east of Great Bear), extending east to the West Brandon Substation on Holly Blvd. west of Brandon, then north and east to the Brandon and Corson Substations on Splitrock Blvd. on the north side of Brandon and east of Corson, respectively, then east on Redwood Blvd. and south on Chestnut Ave. to the Rowena Substation north of Rowena, then south and east to the Splitrock Substation on Highway 42 east of Sioux Falls, then south to the Harrisburg Substation west of Highway 11 (one mile south of the Harrisburg corner), then east to the Tea Substation two miles south of Tea. On March 19, 2004, Xcel Energy, Inc. (Xcel) filed a Motion to Intervene, which motion included a request to receive all filings in the docket.

On March 4, 2004, the Commission electronically transmitted notice of the filing and the intervention deadline of March 19, 2004, to interested individuals and entities. On March 19, 2004, the Commission received a Motion to Intervene from Xcel Energy, Inc. (Xcel).

The Commission has jurisdiction over this matter pursuant to SDCL Chapter 49-41B, specifically 49-41B-1, 49-41B-2, 49-41B-2.1, 49-41B-4, 49-41B-11, 49-41B-12, 49-41B-13, 49-41B-15, 49-41B-16, 49-41B-17, 49-41B-17.1, 49-41B-21, 49-41B-22, 49-41B-25, 49-41B-26, 49-41B-33, 49-41B-38, and ARSD Chapter 20:10:22.

On April 6, 2004, at its regularly scheduled meeting, the Commission found that the Motion to Intervene was timely filed and demonstrated good cause to grant intervention. It is therefore

ORDERED, that the Motion to Intervene of Xcel is hereby granted.

Dated at Pierre, South Dakota, this 19th day of April, 2004.

CERTIFICATE OF SERVICE

The undersigned hereby certifies that this document has been served today upon all parties of record in this docket, as listed on the docket service list, by facsimile or by first class mail, in properly addressed envelopes, with charges prepaid thereon.

By: *Aldine Kolbo*

Date: *4/20/04*

(OFFICIAL SEAL)

BY ORDER OF THE COMMISSION:

Robert K. Sahr

ROBERT K. SAHR, Chairman

Gary Hanson
GARY HANSON, Commissioner

James A. Burg
JAMES A. BURG, Commissioner

RECEIVED

JUN 03 2004

PUBLIC UTILITIES COMMISSION
OF THE STATE OF SOUTH DAKOTA

**SOUTH DAKOTA PUBLIC
UTILITIES COMMISSION**

In the Matter of the Application)
of East River Electric Power)
Cooperative, Inc. for a Permit) EL04-009
to upgrade 36 Miles of 69 kV)
Electric Transmission Line and) STIPULATION
Associated Facilities to 115 kV)
in Minnehaha and Lincoln)
Counties, South Dakota)

It is hereby stipulated and agreed between the Applicant, East River Electric Power Cooperative, Inc. ("East River") and the Staff of the South Dakota Public Utilities Commission ("Staff") that the following Finding of Facts and Conclusions of Law and an appropriate Order consistent with said Findings and Conclusions may be adopted by the Public Utilities Commission ("Commission") in the above-entitled matter. In support of this Application, the Applicant does hereby offer in support thereof all testimony, exhibits and responses to Staff's data requests submitted by the Applicant. Staff offers no answering testimony and exhibits conditioned upon the Commission accepting the following Findings of Fact and Conclusions of Law.

FINDINGS OF FACT

1.

East River's proposed Transmission Line Upgrade Project constitutes an electric transmission line and associated facilities with a design of 115 kilovolts, and more than one mile in length does not follow section lines, property lines, roads, highways or railroads, nor is it a reconstruction or modification of existing transmission lines and existing associated facilities located on abandoned railroad rights-of-way.

PURPOSE OF FACILITY

2.

East River is proposing to upgrade an existing 69 kilovolt line to provide for increased voltage and capacity levels

necessary to reliably meet the increasing electric demand of East River's member systems serving around the Sioux Falls area.

DESCRIPTION OF PROJECT

3.

East River's proposed Project includes the conversion of approximately 36 miles of existing 69 kV overhead transmission lines to 115 kV, converting seven existing 69/12.47 kV electrical distribution substations to 115 kV, replacing approximately 25 miles of shield wire with a shield wire containing a fiber optic wire (OPGW) and the addition of two new 230/115 kV transformations. One transformation will be located at Western Area Power Administration's (WAPA) Sioux Falls High Voltage Substation and one transformation will be at the jointly owned East River/WAPA Virgil Fodness High Voltage Substation. This proposed Project will include six segments;

- (A) Segment One will upgrade East River's existing transmission line between WAPA's Sioux Falls Substation and East River's Brandon Substation. This Segment will upgrade 5.9 miles of transmission line and three substations to 115 kV. The specific location of this Segment is set forth in Section 2.7.1 of East River's Application.
- (B) Segment Two will upgrade East River's existing transmission line between the Brandon Substation and East River's Rowena Substation. This Segment will upgrade 5.1 miles of transmission line and one substation to 115 kV. The specific location of this Segment is set forth in Section 2.7.2 of East River's Application.
- (C) Segment Three will upgrade East River's existing transmission system between the Rowena Substation and East River's Split Rock Substation. This Segment will upgrade 5.7 miles of transmission line and one substation to 115 kV. The specific location of this Segment is set forth in Section 2.7.3 of East River's Application.
- (D) Segment Four will upgrade East River's existing transmission system between the Split Rock Substation and East River's Harrisburg Substation. This Segment

will upgrade 8.9 miles of transmission line and two substations to 115 kV. The specific location of this Segment is set forth in Section 2.7.4 of East River's Application.

- (E) Segment Five will upgrade East River's existing transmission system between the Harrisburg Substation and Interstate 29. This Segment will upgrade 7.8 miles of transmission line to 115 kV. Two new 230/115 kV transformations, one at WAPA's Sioux Falls Substation and one at the jointly owned East River/WAPA Virgil Fodness Substation will also be constructed in this Segment. The specific location of transmission line in this Segment is set forth in Section 2.7.5 of East River's Application. The specific location of the new transformations is set forth in Sections 2.7.1 and 2.7.6 of East River's Application.
- (F) Segment Six will rebuild East River's existing 2.5 mile 69 kV transmission line between Interstate 29 and the Virgil Fodness Substation. This Segment will create a 2.5 mile 115/69 kV double circuit line. The specific location of this Segment is set forth in Section 2.7.6 of East River's Application.

4.

The existing transmission lines, substations and transformations in the proposed Project will require no new right-of-way (ROW).

5.

The Project will replace in Segment One, 4.5 miles of wooden poles, crossarms and conductor and in Segment Five, 2.75 miles of wooden poles, crossarms and conductor. The replacement structures will consist of both single wooden pole structures with polymer side mount insulators and two pole wooden structures with wooden crossarms and porcelain insulators described in (F). The spacing of the poles being replaced will be reduced from 400'-450' to 350'. This will result in additional poles being added to the existing line.

6.

The 2.5 mile rebuild described in Segment Six will convert the existing line from its current single circuit design, comprised of four wires to a double circuit design comprised of seven wires. The current poles will be replaced with single wooden pole structures and side mount polymer insulators. The poles will average 70' in height. Twenty five miles of shield wire will be replaced with an optical ground wire. Diagrams of the different pole structures are included in East River's Application.

DEVIATIONS FROM DESCRIBED CENTER LINE

7.

East River does not anticipate to deviate from the specific location of the centerline of the existing transmission line as described in Section 2.7 in East River's Application.

ESTIMATED COST OF FACILITY

8.

The total estimated construction cost for the line and substation upgrades as well as the two new transformations is \$6,908,000. No additional right-of-way acquisition or land purchase costs are expected.

DEMAND FOR THE FACILITY

9.

The historic and projected summer and winter peak electrical demand for the East River's load on the east side of Sioux Falls is increasing by 5% annually. A table showing summer and winter peak kW demands for 1994 through 2003 and projected kW demands for 2010 and 2015 is included in Section 2.6 of East River's Application.

10.

This Project will allow East River to reliably and efficiently serve the current and projected load growth of East River member systems' Sioux Valley Energy and Southeastern Electric Cooperative in the Sioux Falls area. It will also

strengthen and reinforce the rest of East River's transmission system in the Sioux Falls and surrounding area providing increased reliability and capacity to East River and its member systems.

11.

If the 115 kV upgrade Project is not done or is delayed significantly beyond the projected completion date and the load grows as projected, the East River transmission system in the Sioux Falls area will have increasing operational, reliability, and system loading problems. As system loading increases, serving the load reliably and preventing thermal overloading during system contingencies will become more difficult.

SITE DESCRIPTION

12.

East River's proposed Project is described in Segments. The location of the Segments is shown in East River's Exhibits 4, 4a, 4b, 5, 5a, 5b, 6, 6a, 6b, 7, 7a, 7b, 8, 8a, 8b, 9, 9a, and 9b of the Application, and are summarized below:

- (A) The first Segment of the Project originates at WAPA's Sioux Falls Substation located at 4400 North Timberline Avenue and extends east paralleling the north side of Rice Street to East River's West Brandon Substation. The Project continues north to 261st Street where the line route turns east and runs on the south side of 261st Street to East River's Brandon Substation. One-half mile east of the Brandon Substation, a line tap originates and extends north approximately one-half mile, crossing Interstate 90. At that point the line tap runs west for one-quarter mile and then turns north where it continues for one-half mile to the Corson Substation. Three substations will be upgraded in this Segment, in addition to the transmission line.

- (B) The transmission line in Segment Two originates at East River's Brandon Substation and extends east paralleling 261st Street to 483rd Avenue where it turns south. The line continues south paralleling 483rd Avenue and the section line until it enters East River's Rowena Substation. In addition to the line

upgrades, one substation will be upgraded in this Segment.

- (C) The transmission line in the third Segment originates at East River's Rowena Substation and extends south paralleling 483rd Avenue to 266th Street. There the line turns west and parallels 266th Street until it crosses Highway 42 where there is a three way line switch. The line turns and continues north for approximately one mile until it connects to East River's Split Rock Substation. One substation will be upgraded in this Segment.
- (D) Segment Four originates at the line switch on the corner of 266th Street and Highway 42 and runs south for two miles paralleling Highway 42. At that point the line turns and runs west for one-half mile, paralleling 268th Street. It then turns south at the quarter line and runs south for one-half mile until it connects to East River's Shindler Substation. From here the transmission line continues to the south to East River's Harrisburg Substation. Two substations will be upgraded in this Segment.
- (E) Segment Five originates at East River's Harrisburg Substation and proceeds west paralleling 274th Street for four and one-half miles. At that point the line turns south and proceeds for one-half mile where it turns west again following the quarter line for three miles to that point where the line crosses to the west side of Interstate 29 and connects to an existing East River line switch.
- (F) Segment Six begins at the line switch located on the west side of Interstate 29 and proceeds west on the quarter line for one mile. There the line turns north following the quarter line until the line crosses 274th Street. The line then proceeds west for one mile where it turns north into the Virgil Fodness High Voltage Substation.

ALTERNATIVE SITES

13.

East River evaluated several different approaches to upgrading the capacity in its transmission system in the Sioux Falls area, as described in Section 2.7 of the Application.

By upgrading existing transmission lines instead of building new lines, East River is able to utilize as much of the existing lines, facilities, equipment and right-of-way as possible. In doing so East River is able to minimize the impact to the community and environment.

ENVIRONMENTAL FACTORS

14.

East River's Application described the estimated environmental impact of the Project which should be minimal, due to the utilization of existing facilities and right-of-way.

15.

The existing and proposed upgraded transmission line will meet design standards consistent with standards adopted by other states. The state of Florida has set a standard of 150 milliGauss (mG) for a magnetic field reading at the edge of the right-of-way. The resultant magnetic field with the line under full load 115 kV operating conditions for 2003 is approximately 15 mG at the transmission line and approximately 11 mG at the edge of the right-of-way. The electric field standard set by the state of Montana is 1 kV/m at the edge of the right-of-way. The electric field of the proposed line at the edge of the right-of-way is approximately .50 kV/m based upon a 30 foot right-of-way width.

PHYSICAL ENVIRONMENT

16.

The Project lies in the southern portion of the James River Lowland ecoregion and the northern portion of the Loess Prairies ecoregion. This ecoregion is characterized by mexzid soils, warmer temperatures, and a longer growing season than the Drift Plains ecoregion to the north. These differences are reflected

in the crop types of the regions. Winter wheat, corn, and soybeans are more prevalent in this ecoregion's climate.

17.

Regional topography is generally characterized by rolling hills and plains. Topographic maps of the different Segments of the Project were provided in the Application Exhibits. The Project will not involve any new roads, grading, filling, or other changes to the topography or regional landforms.

18.

Because the Project utilizes existing transmission lines and existing right-of-way, the Project should not alter the existing environment of the land around the transmission lines and substations. It also should not cause any increased hazards to the health and welfare of human, plant, and animal communities around the lines.

19.

The electric transmission lines and substations involved in the Project were originally designed and constructed to meet utility standards. As a result, no issues relating to seismic risks, subsidence, and slope instability have been identified since original construction. All changes to the transmission lines and substations will also meet these standards and will comply with all applicable construction codes. Potential difficulties due to seismic activities, subsidence and slope instability will be avoided through proper design and construction by East River.

20.

There were no geological constraints identified when the transmission lines and substations were originally constructed and it is not anticipated that any geological constraints will impact the Project.

CONSTRUCTION SITE ACCESS

21.

All line segments are either built in right-of-way with easements that allow access for construction and maintenance

purposes, or are built in public right-of-way along public roads that provide access for construction and maintenance.

22.

In an attempt to mitigate potential adverse impacts on soils and vegetation from excessive traffic in the Project area, access to the area will be limited as much as possible. No new roads will be created. Landowners will be compensated for any crop damage that may occur during the Project.

WATER RESOURCES

23.

As East River's proposed transmission Project is an upgrade to existing transmission facilities and does not involve any new roads, grading, filling, deforestation, or significant vegetation removal, there will be no changes to the current drainage patterns.

24.

The construction, operation or maintenance of the proposed Project will not result in discharges to surface or ground waters or placement into such waters.

25.

The proposed transmission upgrades will not use either municipal or private water and therefore, will have no impacts on any planned water uses by communities, agriculture, recreation, fish, or wildlife.

ECOSYSTEMS

26.

There should be no adverse long-term impact on the vegetation and wildlife composition within the Project area. No permanent service road will be required that would result in vegetation removal and unauthorized access. Vegetation removal or habitat loss resulting from pole and anchor placement is insignificant.

27.

No displacement or adverse affect on wildlife or aquatic species is anticipated. The Project will not impact ecologically unique or sensitive habitats including wetlands and aquatic habitats.

28.

The proposed Project should not adversely impact any aquatic ecosystems. The Project does not directly change or impact any wetlands, streams, or rivers. Also, the Project does not require any new roads, grading filling, or other changes to the existing terrain that could cause erosion or sedimentation problems or would change any existing drainage patterns.

29.

At river crossings and when working near any wetlands, streams, rivers, aquatic ecosystems and drainage areas, East River will utilize construction practices to minimize any impact to them and the land and vegetation adjacent to them. East River will comply with all applicable federal, state and local rules and regulations and will follow the specific measures listed in Section 2.16 of the Application.

WASTE DISPOSAL/CLEANUP

30.

Trash, scrap and all other non-vegetation debris will be picked up and disposed of daily to avoid accumulation of trash and blown trash along the right-of-way.

31.

Upon completion of the construction phase, all land within the right-of-way shall be restored immediately after construction and restoration will continue until the surface is substantially restored to its original condition, and any excess subsoil shall be removed from the site. In areas where rapid natural plant succession appears questionable, and when in accordance with landowner wishes, reseeding will be done and is expected to consist of locally adapted herbaceous native species, primarily grasses.

LAND USE

32.

The proposed Project will comply with all applicable zoning requirements. No existing land use controls by any of the governing bodies (Minnehaha County, the City of Brandon, Lincoln County) restrict the use of the land within the proposed Project area for the purpose of constructing and maintaining the transmission facility.

33.

There will be no homes of persons displaced as a result of the construction, operation, or maintenance of the transmission facilities that are part of this Project.

34.

The land in the right-of-way can be used for the same purpose as prior to this Project. The land will still be subject to the restrictions that exist with the current easements and have been in effect since the lines were originally constructed. These restrictions include that trees and structures that might interfere with the safety, operation or maintenance of the line may not be permitted in the right-of-way.

AIR QUALITY

35.

No significant or long-term impacts to air quality will occur as a result of this Project. Some fugitive dust may be generated during construction from construction traffic on unpaved roads.

TIME SCHEDULE

36.

Construction will begin in the fall of 2004, with the Project constructed in six Segments with all Segments estimated to be completed by the end of 2008.

COMMUNITY IMPACT

37.

No significant adverse impact to the local communities and governmental facilities or services is anticipated as a result of this Project.

38.

The Project will result in increased reliability of electrical service to cooperative consumers in the area and provide additional power transmission capacity for a rapidly expanding area of the state, thus providing a social and economic benefit to the area.

39.

There will be no significant immediate or long-term impact on property and other taxes of the affected taxing jurisdictions are anticipated as a result of the Project. No corresponding loss of property taxes is expected.

40.

The electric lines involved in the Project were originally sited along right-of-way and property lines. As a result, the Project is not expected to interfere with agricultural operations or result in the loss of croplands. Should damage occur to crops during construction of this Project, landowners are reimbursed for damages as a normal part of easement costs.

41.

The proposed transmission Project is not expected to impact the population, income, and occupational distribution on the short-term. However, long-term population increases could result from increased power availability in the area.

42.

There are no anticipated impacts to cultural resources as a result of the Project. East River is required by Federal regulation to have in place a "Spill Prevention Control and Countermeasure Plan" (SPCC) for all of its substations. Should

an accidental release of contaminants occur, East River will follow applicable Federal, State and local regulations.

EMPLOYMENT

43.

This Project will utilize existing work force employed by East River and supplemented by workers employed for the construction season. No permanent additional employment is expected as a result of the Project.

FUTURE MODIFICATIONS

44.

East River does not anticipate any future additions or modifications to this Project that would be subject to approval at this time.

VEGETATION CONTROL

45.

East River annually trims vegetation away from its lines that restrict access or pose danger to its lines. It is expected that no additional vegetation will be removed for the Project or that any vegetation outside the existing easement areas will be involved in this Project.

46.

It is East River's policy to use mechanical methods to clear the right-of-way. However, where the use of mechanical or hand methods are impractical, the selective use of herbicides may be necessary. In these instances, the appropriate Federal and State agencies will be notified, only approved herbicides will be used, and all recommended precautions will be taken.

TRANSMISSION FACILITIES

47.

The Project will include the following three different structure types: 1) A single pole wooden structure configured with three side mount insulators, 2) A single pole wooden

structure configured with wooden crossarms and suspension insulators, and 3) A two pole wooden structure configured with a horizontal crossarm and suspension insulators.

48.

Segment Six will utilize a single pole wooden structure configured with side mount insulators that will support a 69/115 kV double circuit.

49.

Segment One of the Project will have the existing 4/0 conductor replaced with a 477 MCM equivalent conductor. Segment Five will have a 2.75 mile portion of its 4/0 conductor replaced with a 477 MCM equivalent conductor.

50.

Segment Six will have three 477 equivalent conductors added to the structures to create a 69/115 kV double circuit.

51.

Diagrams of the structure configurations, switch configurations and Optical Ground Wire are included in East River's Application.

BROADCAST SIGNAL INTERFERENCE

52.

The Project is an upgrade of existing electric lines and substations. East River is unaware of any broadcast signal interference with its existing system and does not anticipate any interference. However, if after the Project is completed it can be shown that the operation of the transmission facility is the source of unacceptable radio or television interference, East River will take all appropriate action to restore or provide reception levels equivalent to reception levels in the immediate area prior to construction of the proposed facility.

RIGHT-OF-WAY OR CONDEMNATION

53.

All easements or permits for the existing transmission line have been previously obtained. No condemnations are anticipated.

PROPOSED CONCLUSIONS OF LAW

1.

The Commission has jurisdiction over the subject matter and parties to this proceeding pursuant to SDCL Chapter 49-41B and ARSD 20:10:22. Subject to the findings made on the four elements of proof under SDCL 49-41B-22, the Commission has authority to grant, deny or grant upon such terms, conditions or modifications of the construction, operation or maintenance of the transmission facility as it may deem appropriate.

2.

The proposed transmission line is a "transmission facility" as defined in SDCL 49-41B-2.1 (2).

3.

East River Electric Power Cooperative's Application complies with the applicable requirement of SDCL Chapter 49-41B and ARSD 20:10:22.

4.

The proposed transmission upgrade will comply with all applicable laws and rules, including all requirements of SDCL Chapter 49-41B and ARSD 20:10:22.

5.

The proposed Transmission Upgrade Project, if constructed in accordance with the terms and conditions of this permit, will not pose a threat of serious injury to the environment or to the social and economic conditions of inhabitants or expected inhabitants in the siting area.

6.

The proposed Transmission Upgrade Project, if constructed in accordance with the terms and conditions of this permit, will not substantially impair the health, safety or welfare of the inhabitants of the siting area.

7.

The proposed Transmission Upgrade Project, if constructed in accordance with the terms and conditions of this permit, will not unduly interfere with the orderly development of the region with due consideration having been given the views of governing bodies of affected local units of government.

8.

The Commission has the authority to revoke or suspend any permit granted under the South Dakota Energy Facility Permit Act for failure to comply with the terms and conditions of the permit pursuant to SDCL 49-41B-33.

9.

East River Electric Power Cooperative has met its burden of proof pursuant to SDCL 49-41B-22 and is entitled to a permit as provided in SDCL 49-41B-25, subject to the following:

STIPULATE TO THE FOLLOWING
TERMS AND CONDITIONS

1.

East River Electric will obtain all governmental permits which may be required by any township, county, state or federal agency or any other governmental unit for construction activity prior to engaging in the particular activity covered by that permit. Copies of any permits to be obtained by East River Electric Power Cooperative shall be sent to the Commission.

2.

In order to ensure compliance with the terms and conditions of this permit pursuant to SDCL 49-41B-33, it is necessary for the enforcement of the Order that all employees, contractors and agents of East River Electric Power Cooperative involved in this

transmission line project be made aware of the terms and conditions of this permit. The Commission finds that each affected landowner or tenant within the transmission line right-of-way must be apprised of the time and place of East River's construction activity and provided a mechanism for lodging inquiries or complaints with both East River Electric and the Commission in the event a landowner or tenant observes what appears to be a violation of the terms and conditions of this permit.

East River Electric shall ensure that its employees, contractors and agents involved in right-of-way negotiations and acquisitions, right-of-way clearing, line construction and right-of-way and line maintenance understand fully and comply with the terms and conditions of this permit.

3.

If during construction East River Electric or its agents discover what may be an archaeological resource, East River Electric or its agents shall immediately cease work at that portion of the site and notify the Commission and the State Archaeologist. If such an archaeological resource is discovered, East River Electric shall develop a plan which is acceptable to the State Archaeologist to salvage, avoid or protect the archaeological resource. If such a plan would require a different route than that approved by the Commission, East River Electric must seek Commission approval for the new route before proceeding with any further construction.

4.

In order to mitigate interference with agricultural and ranching operations during and after construction, East River Electric shall locate all structures, to the extent feasible and prudent, to minimize adverse impact and interference with agricultural operations, shelter belts and other land uses or activities. East River Electric shall take appropriate precautions to protect livestock and crops during construction. East River Electric shall repair all fences and gates removed or damaged during construction or maintenance unless negotiated with landowner or designee. East River Electric shall be responsible for the repair of private roads and lanes damaged when moving equipment or when obtaining access to the right-of-way.

5.

East River Electric shall provide each landowner across whose property the facilities are to be upgraded with the following information:

1. A copy of the Commission's Order.
2. Detailed safety information describing (a) reasonable safety precautions for existing activities on or near the right-of-way; (b) known activities or uses that are presently prohibited within the right-of-way; (c) other potential dangers or limitations within the right-of-way.
3. Construction/maintenance damage compensation policies and procedures.
4. The Commission's address and phone number.

East River Electric shall also comply with all other terms and conditions as set forth in the Findings of Fact.

6.

The terms and conditions of the permit shall be made a uniform condition of construction, subject only to an affirmative written request for an exemption addressed to the Commission. A request for an exemption shall clearly state which particular condition should not be applied to the property in question and the reasons for the requested exemption. The Commission shall evaluate such requests on a case-by-case basis.

7.

Before commencing construction, East River Electric shall furnish an indemnity bond in the amount of Ten Thousand Dollars (\$10,000) to comply with the requirements of SDCL 49-41B-38.

8.

If radio or television interference is caused by the presence or operation of the transmission line, East River Electric shall take all appropriate action to restore or provide

reception equivalent to reception levels in the immediate area just prior to construction of the transmission facility.

DATED June 1, 2004

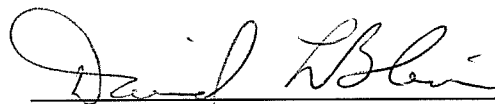

David L. Blair
General Counsel
East River Electric Power
Cooperative, Inc.
121 SE First Street
P.O. Box 227
Madison, SD 57042

DATED June 1, 2004

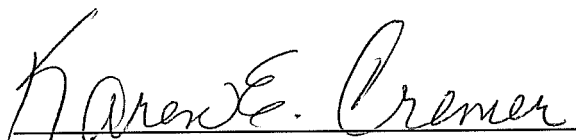

Karen E. Cremer
Staff Attorney

DATED June 3, 2004

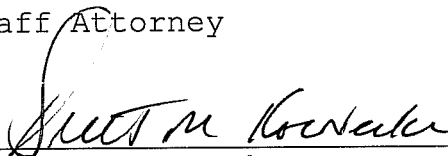

Brett M. Koenecke
Attorney for Xcel Energy

**BEFORE THE PUBLIC UTILITIES COMMISSION
OF THE STATE OF SOUTH DAKOTA**

| | |
|---|------------------------------|
| IN THE MATTER OF THE APPLICATION OF) | DECISION AND ORDER |
| EAST RIVER ELECTRIC POWER) | APPROVING STIPULATION |
| COOPERATIVE, INC. FOR A TRANSMISSION) | AND GRANTING A |
| UPGRADE TO THE SIOUX FALLS AREA 115) | TRANSMISSION UPGRADE |
| KV TRANSMISSION PROJECT) | EL04-009 |

On February 27, 2004, East River Electric Power Cooperative, Inc. (East River) submitted to the Public Utilities Commission (Commission) an application for its proposed Sioux Falls Area 115 kilovolt (kV) transmission upgrade project. The application states that the proposed project would upgrade approximately 36 miles of an existing 69 kV transmission line and 7 existing 69 kV distribution substations to 115 kV to enable East River to continue to adequately and reliably serve the growing demand for electric service of its member distribution systems in the Sioux Falls area. The line and substation facilities to be upgraded are located in Lincoln and Minnehaha Counties, beginning at WAPA's Sioux Falls Substation on Rice Street and 478 Ave. (east of Great Bear), extending east to the West Brandon Substation on Holly Blvd. west of Brandon, then north and east to the Brandon and Corson Substations on Splitrock Blvd. on the north side of Brandon and east of Corson, respectively, then east on Redwood Blvd. and south on Chestnut Ave. to the Rowena Substation north of Rowena, then south and east to the Splitrock Substation on Highway 42 east of Sioux Falls, then south to the Harrisburg Substation west of Highway 11 (one mile south of the Harrisburg corner), then east to the Tea Substation two miles south of Tea. On March 19, 2004, Xcel Energy, Inc. (Xcel) filed a Motion to Intervene, which motion included a request to receive all filings in the docket.

On March 4, 2004, the Commission electronically transmitted notice of the filing and the intervention deadline of March 19, 2004, to interested individuals and entities. Applications for party status were due by April 27, 2004. On March 19, 2004, the Commission received a Motion to Intervene from Xcel Energy, Inc. (Xcel). By order dated April 19, 2004, the Commission granted intervention to Xcel. No applications for party status were filed.

On March 23, 2004, at its regularly scheduled meeting, the Commission, pursuant to SDCL 49-41B-12, unanimously voted to assess East River the minimum filing fee as requested by the Deputy Executive Director. On April 12, 2004, the Commission held a public input meeting.

On June 8, 2004, at a regularly scheduled meeting, Commission Staff notified the Commission that a Stipulation had been reached. The Stipulation set forth Findings of Fact, Conclusions of Law, and Terms and Conditions. The Commission approved the Stipulation with an effective date as of the date of the Order Approving the Stipulation. By adopting the Stipulation the Commission grants East River's application for a transmission upgrade, subject to the terms and conditions listed in the Stipulation.

The Commission has jurisdiction over this matter pursuant to SDCL Chapter 49-41B, specifically 49-41B-1, 49-41B-2, 49-41B-2.1, 49-41B-4, 49-41B-11, 49-41B-12, 49-41B-13, 49-41B-15, 49-41B-16, 49-41B-17, 49-41B-17.1, 49-41B-21, 49-41B-22, 49-41B-25, 49-41B-26, 49-41B-33, 49-41B-38, and ARSD Chapter 20:10:22. It is therefore

ORDERED, that the Stipulation entered into between East River, Commission Staff and Xcel on June 7, 2004, shall be approved and shall be incorporated by reference into this Decision and Order the same as if it had been set forth in its entirety herein; and it is

FURTHER ORDERED, that East River is granted approval to upgrade its transmission line, subject to the terms and conditions listed in the Stipulation.

Dated at Pierre, South Dakota, this 11th day of June, 2004.

| |
|--|
| CERTIFICATE OF SERVICE |
| The undersigned hereby certifies that this document has been served today upon all parties of record in this docket, as listed on the docket service list, by facsimile or by first class mail, in properly addressed envelopes, with charges prepaid thereon. |
| By: <u> Melaine Kalbo </u> |
| Date: <u> 6/14/04 </u> |
| (OFFICIAL SEAL) |

BY ORDER OF THE COMMISSION:

 Robert K. Sahr
ROBERT K. SAHR, Chairman

 Gary Hanson
GARY HANSON, Commissioner

 James A. Burg
JAMES A. BURG, Commissioner



7/7/04

RECEIVED

JUL 09 2004

SOUTH DAKOTA PUBLIC
UTILITIES COMMISSION

MEMO

Karen,

The bond stays in
effect until East River
cancels it.

Let me know if you
need anything else.

Thanks
Barb Strom

605-256-8081

Original bond is in
Delaine's bottom
desk drawer.

RECEIVED

JUL 19 2004



SOUTH DAKOTA PUBLIC UTILITIES COMMISSION

SURETY BOND

NUMBER 40 PD-013-01

RECEIVED

Administrative Office of Attorney-in-Fact: P.O. Box 15147, Lenexa, KS 66285-5147 • (800) 356-8360 • Fax: (913) 541-9004

JUN 28 2004

KNOW ALL MEN BY THESE PRESENTS

SOUTH DAKOTA PUBLIC UTILITIES COMMISSION

That we, East River Electric Power Cooperative, FEDERALATED RURAL ELECTRIC INSURANCE EXCHANGE, a company organized under the laws of the State of Kansas and having its principal office at Lenexa, Kansas, as Surety, are held and firmly bound unto SD Public Utilities Commission and Consumers of South Dakota

_____ in the penal sum of (\$ 10,000.00)

Ten Thousand and no/100_____ Dollars, lawful money of the United States of America, for which payment, well and truly to be made, we jointly and severally bind ourselves, our successors, administrators and assigns, firmly by these presents.

SIGNED, SEALED, and DATED this 17th day of June, 2004

WHEREAS the aforesaid Principal has _____ (If a bid bond insert "submitted its bid for, etc.")

(If a Contract Bond insert "entered into written contract with aforesaid Obligee dated, etc.")

(If a Public Official Bond insert "been elected or appointed (name) for the terms beginning (date) and ending (date)")

been granted a license or permit as East River Electric Power Cooperative by the said obligee from 08/1/2004 to 12/31/2008.

(If a License or Permit Bond insert "been granted a license or permit as (name business) by the said Obligee for the period of one year from (date)")

NOW, THEREFORE, THE CONDITION OF THIS OBLIGATION IS SUCH, that if the aforesaid Principal shall:

comply with the requirements of SDCL 49-41B-38 while completing the 69KV to

(If a bid bond insert "be awarded the contract upon said bid and undertake said contract")

115KV line and substation upgrade in Minnehaha and Lincoln Counties in South Dakota.

(If a Contract Bond insert "comply with the terms and conditions of the aforesaid contract:)

(If License or Permit Bond insert "comply with the laws of the aforesaid Obligee governing said License or Permit")

and this obligation shall be void, otherwise to remain in full force and effect.

- PROVIDED: FIRST: - That the liability of the Surety shall in no event exceed the penalty of this Bond. SECOND: - If this is a Bid Bond, any proceedings at law or in equity brought against said Surety to recover any claim hereunder, must be instituted within six (6) months from the date of this instrument.

Surety herein shall have the right to withdraw as surety from this bond and may do so upon giving the Obligee thirty (30) days written notice to that effect, whereupon except as to liabilities or indebtedness already incurred or accrued, the liability of the Surety under this bond shall cease and the said bond shall thereupon terminate and be of no more force and effect.

[Signature] Principal General Manager

By [Signature] Attorney-in-Fact

FEDERATED RURAL ELECTRIC MANAGEMENT CORPORATION



Federated
RURAL
ELECTRIC
INSURANCE
EXCHANGE

A reciprocal exchange managed by Federated Rural Electric Management Corporation

POWER OF ATTORNEY

KNOW ALL MEN BY THESE PRESENTS: That this Power-of-Attorney is not valid unless attached to the bond which it authorizes executed.

FEDERATED RURAL ELECTRIC INSURANCE EXCHANGE, a Kansas corporation, having its office in the City of Lenexa, State of Kansas, does hereby make, constitute and appoint Thomas Gitschier, Vice President of Underwriting in the City of Lenexa, County of Johnson, State of Kansas, its true and lawful attorney-in-fact, at Lenexa, in the State of Kansas, to make, execute, seal and deliver for and on its behalf, and as its act and deed, bonds, and license and permit bonds; tax, lien, and miscellaneous bonds; required by Federal, State, County, Municipal Authority, or other obligees.

This power void if altered or erased.

The acknowledgment and execution of any such document by the said Attorney-in-Fact shall be as binding upon the Company as if such bond had been executed and acknowledged by the regularly elected officers of this Company.

This Power of Attorney is granted, signed and sealed by original or facsimile under and by the authority of the following bylaw as adopted by the Board of Directors and stockholders of Federated Rural Electric Insurance Exchange at a meeting duly called and held on the 12th day of April, 1984.

"The president shall be the chief executive officer of the corporation. He shall have authority, subject to such rules as may be prescribed by the Board of Directors, to sign, execute and acknowledge, on behalf of the corporation, all deeds, mortgages, bonds, stock certificates, contracts, leases, and other documents or instruments necessary or proper to be executed in the course of the corporation's regular business, or which shall be authorized by resolution of the Board of Directors; and, except as otherwise provided by law or the Board of Directors, he may authorize any Vice-President or other officer or agent of the corporation to sign, execute and acknowledge such documents or instruments in his place and stead."

IN WITNESS WHEREOF, Federated Rural Electric Insurance Exchange has caused these presents to be signed by its duly authorized officers this 24th day of October, 2002.

FEDERATED RURAL ELECTRIC INSURANCE EXCHANGE

BY  President/CEO

Assistant Secretary

STATE OF KANSAS)
) ss:
COUNTY OF JOHNSON)

On this 24th day of October, 2002, before me, a Notary Public, personally appeared Thomas Gitschier and Frank X. Fraas, who being by me duly sworn, acknowledged said instrument to be the voluntary act and deed of said Corporation.

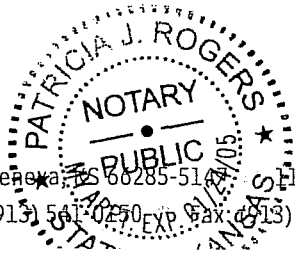

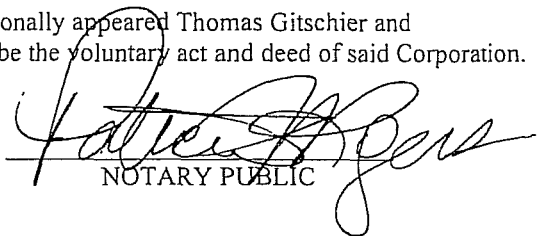
NOTARY PUBLIC

2204-009

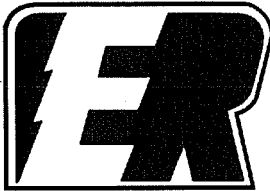

EAST RIVER

ELECTRIC POWER COOPERATIVE

121 Southeast First St. P.O. Box 227
Madison, SD 57042 Telephone (605) 256-4536

September 27, 2004

RECEIVED
SEP 30 2004
SOUTH DAKOTA PUBLIC
UTILITIES COMMISSION

Ms. Michele Farris
Utility Analyst
South Dakota Public Utilities Commission
500 East Capitol Avenue
Pierre, SD 57501-5070

RE: East River Electric's 115 kV Upgrade Project In The Sioux Falls Area

Dear Ms. Farris:

Ms. Kramer of your office recently contacted me with suggested changes that East River should make to the documents we will be mailing to landowners involved with East River's 115 kV line upgrade in the Sioux Falls area.

East River will soon be mailing those documents out for the work to be performed on Parts 2, 3 and 6 of the upgrade project. The following changes to the letter will be incorporated. A typographical error on page two will remove the "y" from party. A toll free phone number will be listed immediately following the job titles for both Dan Wall and Ron Golden. This same toll free phone number will also be added to the end of the letter. We understand there are no suggested changes to the colored brochure.

Thank you for your review of these documents.

Sincerely,

Dan Wall, Manager
Transmission / Engineering Services

DW/jc





EAST RIVER
ELECTRIC POWER COOPERATIVE

121 Southeast First St.
Madison, SD 57042

P.O. Box 227
Telephone (605) 256-4536

RECEIVED

OCT 21 2004

SOUTH DAKOTA PUBLIC
UTILITIES COMMISSION

October 19, 2004

Ms. Michele Farris, Utility Analyst
South Dakota Public Utilities Commission
500 East Capitol Avenue
Pierre, SD 57501-5070

RE: East River Electric's 115 kV Upgrade Project in the Sioux Falls Area

Dear Ms. Farris:

We are enclosing, per your request, the list of landowners and tenants that we have used for East River's mailings on Part #6 of this project.

If weather allows, we expect to begin construction on Part #6 by November 22, 2004

If you have any questions about this mailing or other aspect of the project, please let me know.

Sincerely,

Dan Wall, Manager
Transmission/Engineering Services

DW/jc

Enc.



Mailing List for Part #6

| First Name | Last Name | Street | City, State, Zip | Land Description |
|-----------------------|--------------------|----------------------------|-----------------------|--|
| Stephen & Phyllis | Appel | 27454 470th Avenue | Lennox, SD 57039 | Lot 1 of Appel's Addition, NW1/4 SW1/4, Section 7, T99N-R50W, Lincoln County, South Dakota |
| Walter, George & Lois | Appel | 5324 W 49th Street, Apt. 1 | Sioux Falls, SD 57106 | SW1/4, Section 7, T99N-R50W, Lincoln County, South Dakota |
| Rick & Barbara | Bothern | 27265 469th Avenue | Tea, SD 57064 | Tract 2, Scott's Addition SW1/4 SE1/4, Section 1, T99N-R51W, Lincoln County, South Dakota |
| Howard & Gloria | Burmester | 46880 274th Street | Lennox, SD 57039 | Ohr's Lot 5 & 6 SE1/4 SE1/4, Section 2-T99N-R51W, Lincoln County, South Dakota |
| Daniel & Michelle | Eichacker | 46946 274th Street | Lennox, SD 57039 | Lot 1 of Eichacker's Addition, SE1/4 SW1/4, Section 1, T99N-R51W, Lincoln County, South Dakota |
| Jeanette | Eichacker | 340 E Norton | Salem, SD 57058 | S1/2 SW1/4, Section 1, T99N-R51W, Lincoln County, South Dakota and Lot 2 of Eichacker's Addition SE1/4, SW1/4, Section 1, T99N-R51W, Lincoln County, South Dakota |
| Leroy & Doris | Fett | 27427 470th Avenue | Lennox, SD 57039 | NE1/4, Section 12, T99N-R51W, Lincoln County, South Dakota |
| Alice Huset | c/o Leroy Hackrott | 27012 Louise Avenue | Sioux Falls, SD 57108 | NW1/4 SE1/4, Section 1, T99N-R51W, Lincoln County, South Dakota and SW1/4 SE1/4, Section 1, T99N-R51W, Lincoln County, South Dakota |
| David | McLaughlin | 46972 274th Street | Lennox, SD 57039 | Tract 1, Scott's Addition SW1/4, SE1/4, Section 1, T99N-R51W, Lincoln County, South Dakota |
| Rodney | Miles | 27546 470th Avenue | Lennox, SD 57039 | N1/2 SE1/4, Section 7, T99N-R50W, Lincoln County, South Dakota |
| Tash & Angela | Munce | 46952 274th Street | Lennox, SD 57039 | Kich's Addition NE1/4 Lot 1, Section 1, T99N-R51W, Lincoln County, South Dakota |
| Walter | Ohr | 46876 274th Street | Lennox, SD 57039 | Ohr's Lot 2 SE1/4 SE1/4, Section 2-T99N-R51W, Lincoln County, South Dakota |
| Henry & Cleo | Poppens | 27330 468th Avenue | Lennox, SD 57039 | SE1/4, Section 12, T99N-R51W, Lincoln County, South Dakota |
| Todd & Charlene | Sauvageau | 46888 274th Street | Lennox, SD 57039 | Ohr's Lot 3 SE1/4 SE1/4 1 acre, Section 2-T99N-R51W, Lincoln County, South Dakota |
| Pete & Jessica | Schmidt | 46884 274th Street | Lennox, SD 57039 | Ohr's Lot 4 SE1/4 SE1/4, Section 2-T99N-R51W, Lincoln County, South Dakota |
| Dennis & Cindy | Smith | 27459 471st Avenue | Harrisburg, SD 57032 | Lot 1, N1/2 SE1/4, Sec 7, T99N-R50W, Lincoln County, South Dakota |
| David & Cheryl | Job | 5608 West 53rd Street | Sioux Falls, SD 57106 | Tract 2, Scott's Addition SW1/4 SE1/4, Section 1, T99N-R51W, Lincoln County, South Dakota |

Tenants:

| | | | | |
|--------|------------|--------------------|------------------|---|
| Dave | Klinghagen | 27597 470th Avenue | Lennox, SD 57039 | SW1/4, Section 7, T99N-R50W, Lincoln County, South Dakota |
| Steven | Appel | 27454 470th Avenue | Lennox, SD 57039 | SW1/4, Section 7, T99N-R50W, Lincoln County, South Dakota |
| David | Appel | 27462 470th Avenue | Lennox, SD 57039 | SW1/4, Section 7, T99N-R50W, Lincoln County, South Dakota |

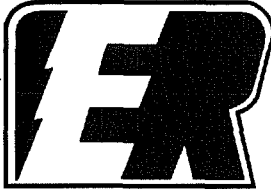

EAST RIVER
ELECTRIC POWER COOPERATIVE

121 Southeast First St.
Madison, SD 57042

P.O. Box 227
Telephone (605) 256-4536

RECEIVED

JAN 03 2005

SOUTH DAKOTA PUBLIC
UTILITIES COMMISSION

December 29, 2004

Ms. Michele Farris, Utility Analyst
South Dakota Public Utilities Commission
500 East Capitol Avenue
Pierre, SD 57501-5070

RE: East River Electric's 115 kV Upgrade Project in the Sioux Falls Area

Dear Ms. Farris:

Enclosed is a list of landowners and tenants that we have used for East River's mailings on Part #3 of this project.

East River Electric is beginning this work now, as weather allows, and will complete Part 3 in 2005.

If you have any questions about this mailing or other aspect of the project, please let me know.

Sincerely,

Dan Wall, Manager
Transmission/Engineering Services

DW/jc

Enc.



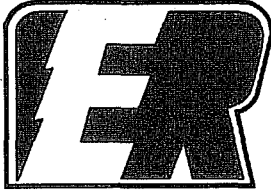

EAST RIVER
ELECTRIC POWER COOPERATIVE

121 Southeast First St.
Madison, SD 57042

P.O. Box 227
Telephone (605) 256-4536

December 22, 2004

Willow Run Golf LLC
8000 E. Hwy 42
Sioux Falls, SD 57110-0000

RECEIVED

JAN 03 2005

**SOUTH DAKOTA PUBLIC
UTILITIES COMMISSION**

Dear Landowner:

East River Electric Power Cooperative is in the process of upgrading its existing electric transmission system on the east and south side of Sioux Falls from 69,000 volts to 115,000 volts. The upgrade is necessary for East River Electric to reliably serve the increasing electric demand of its member distribution cooperatives in the rapidly growing Sioux Falls area.

We are notifying you of this transmission upgrade project as our records indicate that you own the following property on which some of the transmission lines to be upgraded are located:

Tract 1, Willow Run Addition, Sec. 20-T101N-R48W, Minnehaha County, SD
Tract 6, Willow Run Addition, Sec. 20-T101N-R48W, Minnehaha County, SD

The enclosed pamphlet provides information on East River Electric and its Sioux Falls area 115 kV transmission upgrade project. The pamphlet includes a map that shows the location of the transmission lines and substations to be upgraded. Also enclosed is a copy of the South Dakota Public Utilities Commission Order approving East River Electric's application for the transmission upgrade project. The back page of the pamphlet provides names and contact information for people at East River Electric that you can contact with any questions, comments, or concerns that you may have about the project as well as the contact information for the South Dakota Public Utilities Commission.

The property you own is located in Part 3 of the project. East River Electric is beginning this work now, as weather allows and will complete Part 3 in 2005. The upgrade to the transmission line will include the addition of three insulators to each structure. This will provide added clearance per the National Electric Safety Code, replacement of the top conductor with a similar conductor containing a fiber optic wire, and replacement of a line switch. The upgrade to East River's substation will include the replacement of the transformer as well as various substation switches.



If you lease or rent this property to others, we need to provide them with this information as well. Please contact Dan Wall, Manager of Transmission/Engineering Services at 888-256-4536 and provide him with the names and addresses of any renters/lessors you may have.

During construction, East River Electric personnel will work to minimize the impact to your property within the utility right of way. Any disturbance to the right of way as a result of this project will be corrected. Please contact Ron Golden, East River Electric's Land Agent at 888-256-4536 if you have any questions in this regard.

East River's electric facilities are designed and constructed according to national standards, however, safety precautions must still be observed and extra care should always be taken when working in the vicinity of an electric line. It is important that you are aware of all hazards and seek advice from an electric utility representative before attempting any of the following actions near an electric line:

- Installing buildings and/or equipment.
- Placing garbage, refuse or fallen timber under the line.
- Planting or cultivating trees or shrubs which when fully grown will grow to within 10 feet of the electric lines conductor.
- Excavating the ground within 15 feet of any transmission pole.
- Placing obstructions of any type within 15 feet of any transmission pole.
- Handling long/large items such as ladders.

If you have any questions, comments, or concerns about this project, either now or during construction, please contact either Ron Golden or Dan Wall at 888-256-4536.

Sincerely,

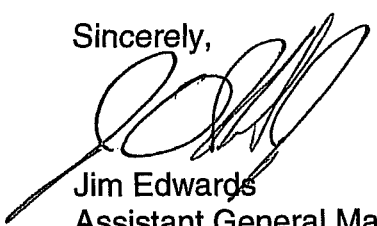

Jim Edwards
Assistant General Manager
Operations

JE/jc

Enc.

| First Name | Last Name | Address | Land Description | Section, Township, Range, County, State |
|-------------------------------------|--|--|---|---|
| | Willow Run Golf LLC | 8000 E. Hwy 42 Sioux Falls, SD 57110-0000 | Tract 1, Willow Run Addition, Sec. 20-T101N-R48W, Minnehaha County, SD | Tract 6, Willow Run Addition, Sec. 20-T101N-R48W, Minnehaha County, SD |
| Willow Ridge Homeowners Association | c/o Jay and Jodi Holtz | 8504 E. Willow Ridge Place Sioux Falls, SD 57110-7563 | Tract 1, Willow Ridge Estate SE1/4, Sec. 20-T101N-R48W, Minnehaha County, SD | Tract 2, Willow Ridge Estate SE1/4, Sec. 20-T101N-R48W, Minnehaha County, SD Sec. 20-T101N-R48W, Minnehaha County, SD |
| | F&K Assam Family, LLC | 530 S. Phillips Avenue Sioux Falls, SD 57104-6825 | Tract 3 Perry Warren Estates (Ex H-1 and H-2) S1/2 SW1/4 | Sec. 20-T101N-R48W, Minnehaha County, SD |
| Travis & Ruth | Fawcett | 8528 E. Willow Ridge Place Sioux Falls, SD 57110-7563 | Lot 10 and 11, Willow Ridge Estate SE1/4 | Sec. 20-T101N-R48W, Minnehaha County, SD |
| | First National Bank Trustee Attn: Ret Plans | PO Box 5186 Sioux Falls, SD 57117-5186 | Lot 16, Willow Ridge Estates SE1/4, Sec. 20-T101N-R48W, Minnehaha County, SD | Lot 18, Willow Ridge Estate SE1/4, Sec. 20-T101N-R48W, Minnehaha County, SD |
| Eva | Iverson | 3600 S. Willow Avenue, Apt. 204 Sioux Falls, SD 57105-6262 | SW1/4 Ex W 10 Rods S 16 Rods and Ex Iverson Tract A | Sec. 21-T101N-R48W, Minnehaha County, SD |
| Jerry & Judy | Roozenboom | 1500 S. Perry Place Sioux Falls, SD 57110-7546 | Iverson' Tracts, Tract A SW1/2 | Sec. 21-T101N-R48W, Minnehaha County, SD |

| | | | | |
|----------------------|--|---|--|--|
| | Sharon Torberson, Patti Rambat, Trudi McCall | 2681 S Vaughn Way Aurora, CO 80014-2068 | Lot 1, Rise Addition SW1/4 | Sec. 21-T101N-R48W, Minnehaha County, SD |
| Aaron & Janet | Munson | 48054 Iverson Crossing Road Brandon, SD 57005-7902 | Tract B, Iverson's Addition S1/2 SE1/4 | Sec. 21-T101N-R48W, Minnehaha County, SD |
| I.C. Development Co. | c/o G&D Harr Construction | 3408 S. Sycamore Avenue Sioux Falls, SD 57110-4412 | NE1/4 lying East of Big Sioux River and North of H-3 (Except H-8 & Except S1147.92 E850.95 & Except Iverson Crossing & (Ex G H Perry Addition) | Sec. 28-T101N-R48W, Minnehaha County, SD |
| Randy & Julie | Rock | 26604 Tucker Drive Brandon, SD 57005-7209 | Lot 1, Block 1, Iverson Crossing Addition NE1/4 | Sec. 28-T101N-R48W, Minnehaha County, SD |
| Stanley & Heather | Mitzel | 48079 Iverson Crossing Road Brandon, SD 57005 | Lot 8, Block 1, Iverson Crossing Addition NE1/4 | Sec. 28-T101N-R48W, Minnehaha County, SD |
| Jon & Lynn | Harris | 26601 Caley Circle Brandon, SD 57005-7238 | Lot 9, Block 1, Iverson Crossing Addition NE1/4 | Sec. 28-T101N-R48W, Minnehaha County, SD |
| Kenneth & Orlene | Eichhorn | 26604 Caley Circle Brandon, SD 57005 | Lot 10, Block 1, Iverson Crossing Addition NE1/4 | Sec. 28-T101N-R48W, Minnehaha County, SD |
| Robert & Laurie | Wenger | 48061 Iverson Crossing Road Brandon, SD 57005 | Lot 1, Block 2, Iverson Crossing Addition NE1/4 | Sec. 28-T101N-R48W, Minnehaha County, SD |

| | | | | |
|-------------------------------------|---|--|---|---|
| James & Maureen | Robl | 26601 Tucker Drive Brandon, SD 57005-7209 | Lot 2, Block 2, Iverson Crossing Addition NE1/4 | Sec. 28-T101N-R48W, Minnehaha County, SD |
| | Tobin Family Limited Partnership | RR 1, Box 10 Pierpont, SD 57468 | Tract 1 Ode's Addition S1/2 SW1/4 & S1/2 SE1/4, Sec. 22- T101N-R48W, Minnehaha County, SD | S1/2 SE1/4 (Except Tracts 1 & 2 Ode's Addition), Sec. 22-T101N-R48W, Minnehaha County, SD |
| Robert | Ode | 48176 266 th Street Brandon, SD 57005-7210 | Tract 2 Ode Addition S1/2 SE1/4 | Sec. 22-T101N-R48W, Minnehaha County, SD |
| Marvin | Cronn | 26521 48 th Avenue Brandon, SD 57005-7233 | NW1/4 NW1/4 | Sec. 26-T101N-R48W, Minnehaha County, SD |
| David & Nancy | Funke | 28248 266 th Street Brandon, SD 57005 | NW1/4 NE1/4 & NE1/4 NW1/4 | Sec. 26-T101N-R48W, Minnehaha County, SD |
| Raymond, Carol, David & Nancy | Funke | 48244 266 th Street Brandon, SD 57005-7211 | E1/2 NE1/4 (Ex H-1 & Ex Tract 1 Dockendorfs Addition) | Sec. 26-T101N-R48W, Minnehaha County, SD |
| Donna | Webster | 26640 483 rd Avenue Brandon, SD 57005-7230 | W1/2 NW1/4 (Ex Lot H-1 & H-2) | Sec. 25-T101N-R48W, Minnehaha County, SD |
| Robert | Hildring C/o Tricia Paulsen | 1297 2 nd N W Watertown, SD 57201-1120 | SW1/4 Ex H-1 & H -2 | Sec. 24-T101N-R48W, Minnehaha County, SD |
| | Irene Hildring & Tricia Paulsen | 1297 2 nd N W Watertown, SD 57201-1120 | NW1/4 (Ex N1/2) and N1/2 NW1/4 | Sec. 24-T101N-R48W, Minnehaha County, SD |

SIoux FALLS AREA 115 KV UPGRADE PROJECT



To be constructed by

**EAST RIVER ELECTRIC
POWER COOPERATIVE, INC.**



A Touchstone Energy® Cooperative



Transmission System Upgrade Project Begins to Serve Growing Load

East River Electric Power Cooperative, Inc. (East River) is upgrading its existing overhead electric transmission system located on the northeast, east and south sides of Sioux Falls, South Dakota.

This project is necessary to provide increased voltage and capacity levels so we can continue to reliably meet the increasing demand by electric cooperative members in the Sioux Falls area.

The upgrade project will convert 36 miles of existing 69,000 volt overhead transmission lines owned by East River to 115,000 volts. Also, seven existing 69,000 kV electrical distribution substations owned by East River will be converted to 115,000 volt distribution substations.

This multi-year \$7,000,000 Sioux Falls Area 115 kV Transmission Upgrade Project will be completed in six parts. (See the map)

The project will not change the overall appearance or location of the line. In many locations, only conductor and insulators will be changed. In some locations, poles will be changed or added along with the conductor and insulators.

An application for this upgrade project, as per requirements set forth in South Dakota Codified Law (SDCL) 49-41B and South Dakota Administrative Rule (SDAR) 20:10:22, was submitted to the South Dakota Public Utilities Commission. On June 11, 2004 the Commission approved the Order for this East River upgrade project.

A list of contacts is provided on the back cover of this document. These contacts are available to you for any inquiries, comments or safety concerns you may have regarding this upgrade project.

East River is a power supply cooperative which provides wholesale power to 22 member systems in eastern South Dakota and western Minnesota. These 22 member distribution systems deliver retail electricity to more than 80,000 homes and businesses in a 36,000 square mile service area, covering 41 counties in eastern South Dakota and nine counties in western Minnesota.

SIOUX FALLS AREA 115 KV UPGRADE PROJECT

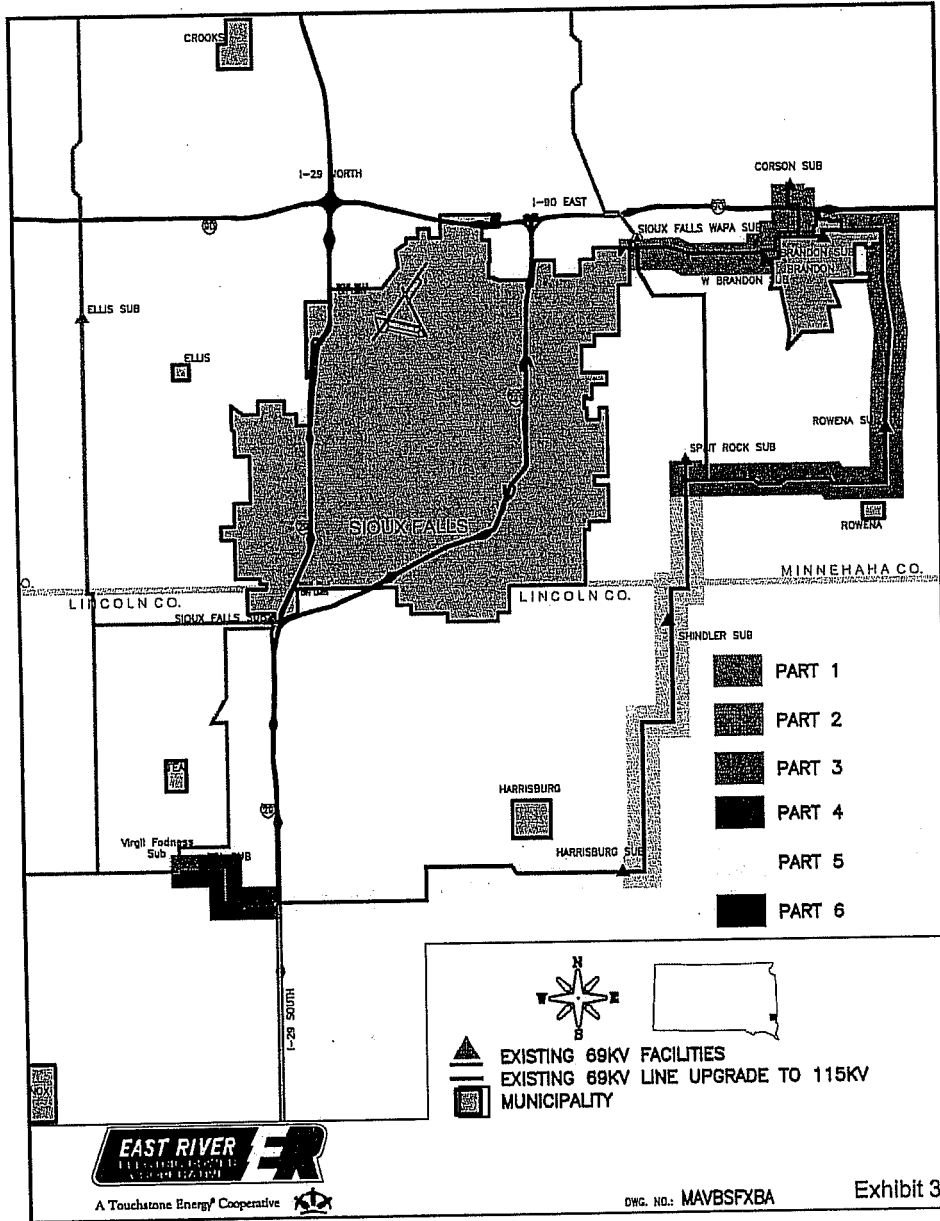

A Touchstone Energy[®] Cooperative

DWG. NO.: MAVBSFXBA

Exhibit 3

The following contacts are available for questions, comments
or safety concerns regarding this project:

For: East River Electric Power Cooperative, Inc.
121 SE 1st Street
P.O. Box 227
Madison, South Dakota 57042
(605) 256-4536
(888) 256-4536

Jim Edwards
Assistant General Manager-Operations
jedwards@eastriver.coop

Dan Wall
Manager, Transmission/Engineering Services
dwall@eastriver.coop

Ron Golden
Land Agent/Surveyor
rgolden@eastriver.coop

For: South Dakota Public Utilities Commission
500 East Capitol Avenue
Pierre, South Dakota 57501-5070
(605) 773-3201

September 2004

**BEFORE THE PUBLIC UTILITIES COMMISSION
OF THE STATE OF SOUTH DAKOTA**

| | | |
|---|---|------------------------------|
| IN THE MATTER OF THE APPLICATION OF |) | DECISION AND ORDER |
| EAST RIVER ELECTRIC POWER |) | APPROVING STIPULATION |
| COOPERATIVE, INC. FOR A TRANSMISSION |) | AND GRANTING A |
| UPGRADE TO THE SIOUX FALLS AREA 115 |) | TRANSMISSION UPGRADE |
| KV TRANSMISSION PROJECT |) | EL04-009 |

On February 27, 2004, East River Electric Power Cooperative, Inc. (East River) submitted to the Public Utilities Commission (Commission) an application for its proposed Sioux Falls Area 115 kilovolt (kV) transmission upgrade project. The application states that the proposed project would upgrade approximately 36 miles of an existing 69 kV transmission line and 7 existing 69 kV distribution substations to 115 kV to enable East River to continue to adequately and reliably serve the growing demand for electric service of its member distribution systems in the Sioux Falls area. The line and substation facilities to be upgraded are located in Lincoln and Minnehaha Counties, beginning at WAPA's Sioux Falls Substation on Rice Street and 478 Ave. (east of Great Bear), extending east to the West Brandon Substation on Holly Blvd. west of Brandon, then north and east to the Brandon and Corson Substations on Splitrock Blvd. on the north side of Brandon and east of Corson, respectively, then east on Redwood Blvd. and south on Chestnut Ave. to the Rowena Substation north of Rowena, then south and east to the Splitrock Substation on Highway 42 east of Sioux Falls, then south to the Harrisburg Substation west of Highway 11 (one mile south of the Harrisburg corner), then east to the Tea Substation two miles south of Tea. On March 19, 2004, Xcel Energy, Inc. (Xcel) filed a Motion to Intervene, which motion included a request to receive all filings in the docket.

On March 4, 2004, the Commission electronically transmitted notice of the filing and the intervention deadline of March 19, 2004, to interested individuals and entities. Applications for party status were due by April 27, 2004. On March 19, 2004, the Commission received a Motion to Intervene from Xcel Energy, Inc. (Xcel). By order dated April 19, 2004, the Commission granted intervention to Xcel. No applications for party status were filed.

On March 23, 2004, at its regularly scheduled meeting, the Commission, pursuant to SDCL 49-41B-12, unanimously voted to assess East River the minimum filing fee as requested by the Deputy Executive Director. On April 12, 2004, the Commission held a public input meeting.

On June 8, 2004, at a regularly scheduled meeting, Commission Staff notified the Commission that a Stipulation had been reached. The Stipulation set forth Findings of Fact, Conclusions of Law, and Terms and Conditions. The Commission approved the Stipulation with an effective date as of the date of the Order Approving the Stipulation. By adopting the Stipulation the Commission grants East River's application for a transmission upgrade, subject to the terms and conditions listed in the Stipulation.

The Commission has jurisdiction over this matter pursuant to SDCL Chapter 49-41B, specifically 49-41B-1, 49-41B-2, 49-41B-2.1, 49-41B-4, 49-41B-11, 49-41B-12, 49-41B-13, 49-41B-15, 49-41B-16, 49-41B-17, 49-41B-17.1, 49-41B-21, 49-41B-22, 49-41B-25, 49-41B-26, 49-41B-33, 49-41B-38, and ARSD Chapter 20:10:22. It is therefore

ORDERED, that the Stipulation entered into between East River, Commission Staff and Xcel on June 7, 2004, shall be approved and shall be incorporated by reference into this Decision and Order the same as if it had been set forth in its entirety herein; and it is

FURTHER ORDERED, that East River is granted approval to upgrade its transmission line, subject to the terms and conditions listed in the Stipulation.

Dated at Pierre, South Dakota, this 11th day of June, 2004.

CERTIFICATE OF SERVICE

The undersigned hereby certifies that this document has been served today upon all parties of record in this docket, as listed on the docket service list, by facsimile or by first class mail, in properly addressed envelopes, with charges prepaid thereon.

By: *Delaine Kalbo*

Date: 6/14/04

(OFFICIAL SEAL)

BY ORDER OF THE COMMISSION:

Robert K. Sahr
ROBERT K. SAHR, Chairman

Gary Hanson
GARY HANSON, Commissioner

James A. Burg
JAMES A. BURG, Commissioner

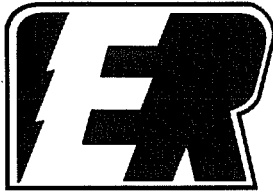

EAST RIVER

ELECTRIC POWER COOPERATIVE

121 Southeast First St.
Madison, SD 57042

P.O. Box 227
Telephone (605) 256-4536

December 29, 2004

Ms. Michele Farris, Utility Analyst
South Dakota Public Utilities Commission
500 East Capitol Avenue
Pierre, SD 57501-5070

RE: East River Electric's 115 kV Upgrade Project in the Sioux Falls Area

Dear Ms. Farris:

Enclosed is a list of landowners and tenants that we have used for East River's mailings on Part #2 of this project.

East River Electric is beginning this work now, as weather allows, and will complete Part 2 in 2005.

If you have any questions about this mailing or other aspect of the project, please let me know.

Sincerely,

Dan Wall, Manager
Transmission/Engineering Services

DW/jc

Enc.

RECEIVED

JAN 03 2005

**SOUTH DAKOTA PUBLIC
UTILITIES COMMISSION**



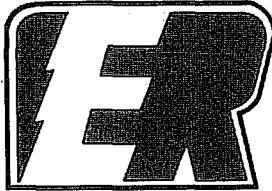

EAST RIVER

ELECTRIC POWER COOPERATIVE

121 Southeast First St.
Madison, SD 57042

P.O. Box 227
Telephone (605) 256-4536

December 27, 2004

Bethany Lutheran Home For The Aged
1901 S. Holly Avenue
Sioux Falls, SD 57105-2499

Dear Landowner:

East River Electric Power Cooperative is in the process of upgrading its existing electric transmission system on the east and south side of Sioux Falls from 69,000 volts to 115,000 volts. The upgrade is necessary for East River Electric to reliably serve the increasing electric demand of its member distribution cooperatives in the rapidly growing Sioux Falls area.

We are notifying you of this transmission upgrade project as our records indicate that you own the following property on which some of the transmission lines to be upgraded are located:

W563.58' N694.75' S1362.25' SE1/4 SW1/4 & SW1/4 SE1/4 (Ex W800');
Tract 2, Burkman Addition SW 1/4
Sec. 36-T102N-R48W, Minnehaha County, SD

The enclosed pamphlet provides information on East River Electric and its Sioux Falls area 115 kV transmission upgrade project. The pamphlet includes a map that shows the location of the transmission lines and substations to be upgraded. Also enclosed is a copy of the South Dakota Public Utilities Commission Order approving East River Electric's application for the transmission upgrade project. The back page of the pamphlet provides names and contact information for people at East River Electric that you can contact with any questions, comments, or concerns that you may have about the project as well as the contact information for the South Dakota Public Utilities Commission.

The property you own is located in Part 2 of this project. East River Electric is beginning this work now, as weather allows and will complete Part 2 in 2005. The upgrade to the transmission line will include the addition of three insulators to each structure. This will provide added clearance per the National Electric Safety Code and replacement of a line switch. The upgrade to East River's substation will include the replacement of the transformer as well as various substation switches.

RECEIVED

JAN 03 2005

**SOUTH DAKOTA PUBLIC
UTILITIES COMMISSION**



If you lease or rent this property to others, we need to provide them with this information as well. Please contact Dan Wall, Manager of Transmission/Engineering Services at 888-256-4536 and provide him with the names and addresses of any renters/lessors you may have.

During construction, East River Electric personnel will work to minimize the impact to your property within the utility right of way. Any disturbance to the right of way as a result of this project will be corrected. Please contact Ron Golden, East River Electric's Land Agent at 888-256-4536 if you have any questions in this regard.

East River's electric facilities are designed and constructed according to national standards, however, safety precautions must still be observed and extra care should always be taken when working in the vicinity of an electric line. It is important that you are aware of all hazards and seek advice from an electric utility representative before attempting any of the following actions near an electric line:

- Installing buildings and/or equipment.
- Placing garbage, refuse or fallen timber under the line.
- Planting or cultivating trees or shrubs which when fully grown will grow to within 10 feet of the electric lines conductor.
- Excavating the ground within 15 feet of any transmission pole.
- Placing obstructions of any type within 15 feet of any transmission pole.
- Handling long/large items such as ladders.

If you have any questions, comments, or concerns about this project, either now or during construction, please contact either Ron Golden or Dan Wall at 888-256-4536.

Sincerely,

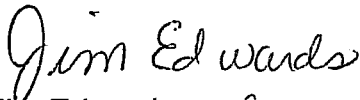

Jim Edwards *je*
Assistant General Manager
Operations

JE/jc

Enc.

| First Name | Last Name | Address | Land Description | Section, Township, Range, County, State |
|------------------|--|--|---|--|
| | Bethany Lutheran Home For The Aged | 1901 S. Holly Avenue Sioux Falls, SD 57105-2499 | W563.58' N694.75' S1362.25' SE1/4 SW1/4 & SW1/4 SE1/4 (Ex W800'); Tract 2, Burkman Addition SW 1/4 | Sec. 36-T102N-R48W, Minnehaha County, SD |
| George & Gayle | Bright | 1604 E Redwood Blvd Brandon, SD 57005-6628 | Tract 2, Burkman's Tracts SW 1/4 SW 1/4 | Sec.26-T102N-R48W, in City of Brandon, SD |
| John | Burkman | 104 N. Chestnut Ave. Brandon, SD 57005 | N383' W1/2 SW1/4; S 1/2 NW 1/4 (Ex Burkman's Tract 1) | Sec. 36-T102N-R48W, Minnehaha County, SD |
| Josephine & John | Burkman | 432 N. Maple Ave. Brandon, SD 57005 | W 1/2 SW 1/4 (Ex Burkman's Addition & Ex N383) | Sec. 36-T102N-R48W, Minnehaha County, SD |
| | Church of Jesus Christ of Latter-Day Saints | 50 East North Temple, Floor 22 Salt Lake City, UT 84150-0002 | 400 S Chestnut Ave., Brandon, SD 57005 | |
| | City of Brandon | PO Box 95 Brandon, SD 57005-0095 | Lot 1 Tract 2 Burkman Industrial Park, Brandon, SD | |
| | The Dawley Credit Trust c/o First National Bank In Sioux Falls | PO Box 5186 Sioux Falls, SD 57117-5186 | W 1/2 NW 1/4 (Ex Ry & Ex Pt S of Ry & Ex Tract 1 Gulseth Addition & Ex N453.2' & Ex S 512.26' N932.46' E250') | Sec.1-T101N-R48W, Minnehaha County, SD |
| Donna | Dawley | 1813 Tyler Street Mission, TX 78572-8931 | SW 1/4 & PT W 1/2, NW 1/4 S of RY | Sec.1-T101N-R48W, Minnehaha County, SD |
| | E & ER Company | PO Box 84140 Sioux Falls, SD 57118-4140 | C & NW RR NW1/4 | Sec.2-T101N-R48W, Minnehaha County, SD |

| | | | | |
|-----------------|---------|--|---|--|
| David & Sandra | Elofson | 1102 N Chestnut Ave. Brandon, SD 57005-6619 | W 1/2 SW 1/4 & NE 1/4 SW 1/4 (Ex Hy & Pt N 1/2 SW 1/4 N of H-1 & Ex N288.99 S1430.9' W321.8') | Sec.25-T102N-R48W, Minnehaha County, SD |
| Clarence | Funke | 26414 483rd Ave Brandon, SD 57005-7002 | C & E Tract, NW1/4 of NW1/4 W 1/2 of NW 1/4 (Ex Orlander Tr 1 & Ex Jongeling Lot 1 & Ex C & E Tract & Ex Beaver Creek Nature Area Addition & Ex Nature View Addition) | Sec.13-T101N-R48W, Minnehaha County, SD |
| Sandy | Funke | 26414 483rd Ave. Brandon, SD 57005-7002 | Tract 1 Nature View Addition, W 1/2 NW 1/4 | Sec.13-T101N-R48W, Minnehaha County, SD |
| Orlin & Erlma | Nelson | 2208 E Redwood Blvd Brandon, SD 57005-6625 | Mobile home located on Tract 1 Nelsons Addition E1/2 SE1/4; E1/2 SE1/4 (Ex H- 1 & Ex Tract 1 Nelsons Addition; Tract 1 Nelson's Addition E1/2 SE1/4; Burton Tract 2 (Ex S626 W 278) SW1/4 SE1/4; E235' SE1/4 SW1/4 & PT NW1/4 SE1/4 Lying S of Hy & SW1/4 SE1/4 (Ex Burton Tracts) | Sec.26-T102N-R48W, Minnehaha County, SD |
| Jeffery & Sally | Nelson | 2020 E Redwood Blvd Brandon, SD 57005-6627 | Bruton Tract 1 & S626 Burton Tr 2 (Ex E347) SW1/4 SE1/4 | Sec.26-T102N-R48W, Minnehaha County, SD |

| | | | | |
|-------------------|---------------------------|---|---|---|
| Randy & Bonnie | Nelson | 1704 E Redwood Blvd Brandon, SD 57005-6642 | S128' E100' Tract 1 Nelson Addition & S656.9 E100 W1085 (Ex Burkmans Tr) Tract 1 Nelson's Addition (Ex S128 E100) & W419.47 N696.1 & E670.9 W1085 (Ex S656.9 E100 W1085 & Ex Burkamans Tr D & Ex Tr 2 Nelson's Addition), SE1/4 of SW1/4 | Sec.26-T102N-R48W, Minnehaha County, SD |
| Gregory & Juanita | Madetzke | 48301 262nd St. Brandon, SD 57005-6615 | Tract 1 Gulseth Addition W 1/2 NW 1/4 | Sec.1-T101N-R48W, Minnehaha County, SD |
| Gary & Jane | Newman | 26403 484th Ave. Valley Springs, SD 57068-7203 | Tract 1, Stones Tracts, | Sec.13-T101N-R48W, Minnehaha County, SD |
| Dale | Olson | 314 N. Chesnut Brandon, SD 57005-6617 | Burkman's Tract 1 SW 1/4 NW 1/4 | Sec.36-T102N-R48W, Minnehaha County, SD |
| | Pioneer Enterprises, Inc. | 300 N. Chapel Hill Rd Sioux Falls, SD 57103-0000 | Tract 1 Burkman Addition SW 1/4 | Sec.36-T102N-R48W, Minnehaha County, SD |
| Alvin & Tammi | Ploen | 1620 E Redwood Blvd Brandon, SD 57005-6628 | Tract 1, Burkmans Tracts SW 1/4 SW 1/4 | Sec.26-T102N-R48W, Minnehaha County, SD |
| Rockford & Gaila | Schreurs | 25251 477th Ave. Baltic, SD 57003-5950 | Tract 4 Lee's Addition NE 1/4; Tract 3 Lee's Addition NE 1/4 | Sec.2-T101N-R48W, Minnehaha County, SD |
| Melvin | Swanson | 26362 483rd Ave. Brandon, SD 57005-7003 | TR 1, W 1/2 | Sec.12-T101N-R48W, Minnehaha County, SD |
| Robert & Dayleen | Swanson | 26362 483rd Ave. Brandon, SD 57005-7003 | Mobile home located on Tract 1 W 1/2, | Sec.12-T101N-R48W, Minnehaha County, SD |
| Lucille | Swenson | 3708 S. Terry Ave. Apt 203 Sioux Falls, SD 57106-1423 | N 1/2 NW 1/4 | Sec.36-T102N-R48W, Minnehaha County, SD |

| | | | | |
|-----------------------|------------|--|--|--|
| | TB & J LLC | 26220 McHardy Rd Brandon, SD 57705 | Tract 4 Burkman Addition SW 1/4 Tract 5 Burkman Addition SW 1/4 | Sec.36-T102N-R48W, Minnehaha County, SD |
| Gerald | Vanvoorst | 1600 S Powder House Rd Sioux Falls, SD 57110-3977 | Lot A (Ex N257.4 & Ex E 150) & Lot PE-1 (Ex E150) Tract 2, Burkman Industrial Park, Brandon, SD | |
| Michael & Jennifer | Vogel | 1404 River Oak Brandon, SD 57005 | E150 (Ex N257.4) & E150 Lot PE-1 Tract 2, Burkman Industrial Park, Brandon, SD | |

SIoux FALLS AREA 115 KV UPGRADE PROJECT



To be constructed by

**EAST RIVER ELECTRIC
POWER COOPERATIVE, INC.**



A Touchstone Energy® Cooperative



Transmission System Upgrade Project Begins to Serve Growing Load

East River Electric Power Cooperative, Inc. (East River) is upgrading its existing overhead electric transmission system located on the northeast, east and south sides of Sioux Falls, South Dakota.

This project is necessary to provide increased voltage and capacity levels so we can continue to reliably meet the increasing demand by electric cooperative members in the Sioux Falls area.

The upgrade project will convert 36 miles of existing 69,000 volt overhead transmission lines owned by East River to 115,000 volts. Also, seven existing 69,000 kV electrical distribution substations owned by East River will be converted to 115,000 volt distribution substations.

This multi-year \$7,000,000 Sioux Falls Area 115 kV Transmission Upgrade Project will be completed in six parts. (See the map)

The project will not change the overall appearance or location of the line. In many locations, only conductor and insulators will be changed. In some locations, poles will be changed or added along with the conductor and insulators.

An application for this upgrade project, as per requirements set forth in South Dakota Codified Law (SDCL) 49-41B and South Dakota Administrative Rule (SDAR) 20:10:22, was submitted to the South Dakota Public Utilities Commission. On June 11, 2004 the Commission approved the Order for this East River upgrade project.

A list of contacts is provided on the back cover of this document. These contacts are available to you for any inquiries, comments or safety concerns you may have regarding this upgrade project.

East River is a power supply cooperative which provides wholesale power to 22 member systems in eastern South Dakota and western Minnesota. These 22 member distribution systems deliver retail electricity to more than 80,000 homes and businesses in a 36,000 square mile service area, covering 41 counties in eastern South Dakota and nine counties in western Minnesota.

SIOUX FALLS AREA 115 KV UPGRADE PROJECT

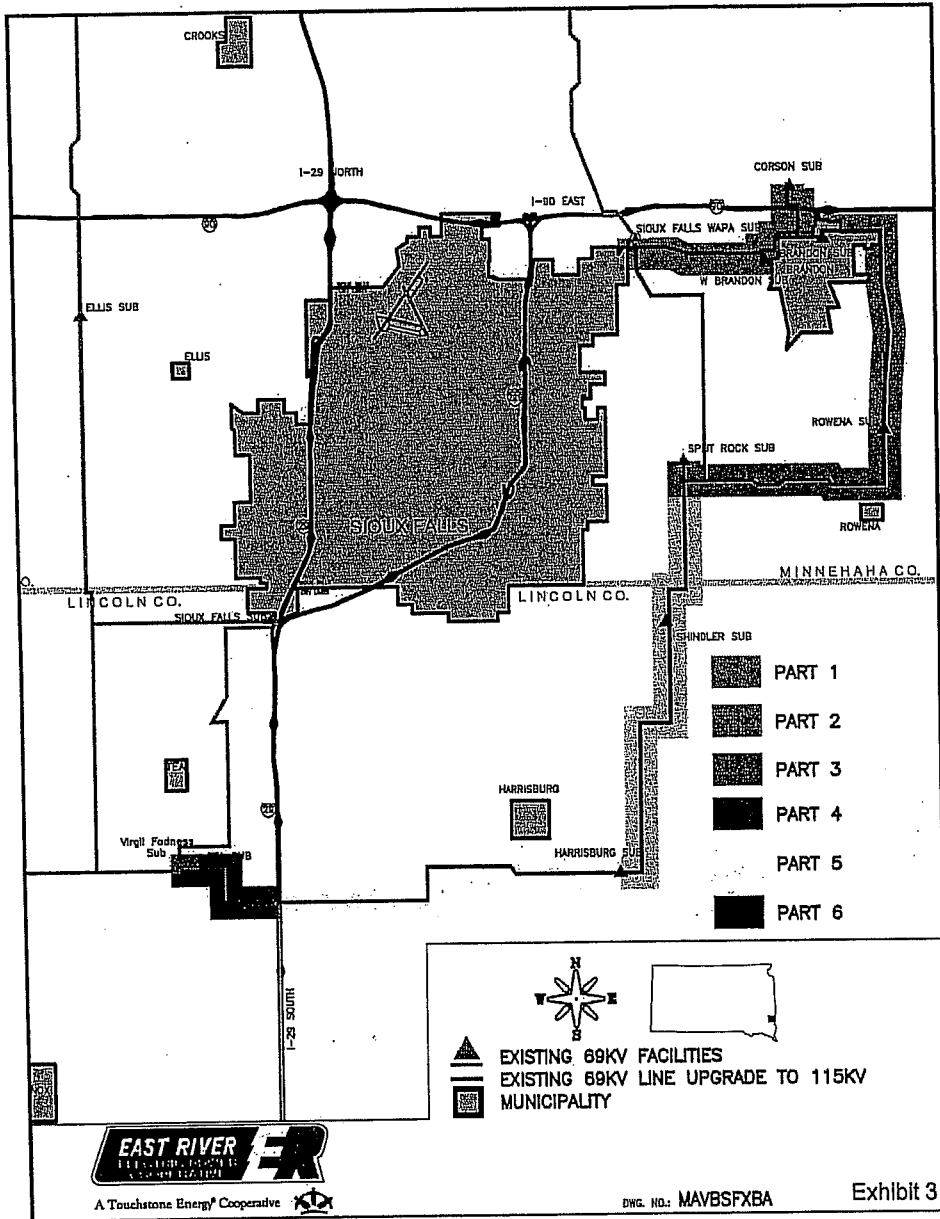

ENG. NO.: MAVBSFXBA

Exhibit 3

The following contacts are available for questions, comments
or safety concerns regarding this project:

For: East River Electric Power Cooperative, Inc.
121 SE 1st Street
P.O. Box 227
Madison, South Dakota 57042
(605) 256-4536
(888) 256-4536

Jim Edwards
Assistant General Manager-Operations
jedwards@eastriver.coop

Dan Wall
Manager, Transmission/Engineering Services
dwall@eastriver.coop

Ron Golden
Land Agent/Surveyor
rgolden@eastriver.coop

For: South Dakota Public Utilities Commission
500 East Capitol Avenue
Pierre, South Dakota 57501-5070
(605) 773-3201

September 2004

**BEFORE THE PUBLIC UTILITIES COMMISSION
OF THE STATE OF SOUTH DAKOTA**

| | | |
|---|---|------------------------------|
| IN THE MATTER OF THE APPLICATION OF |) | DECISION AND ORDER |
| EAST RIVER ELECTRIC POWER |) | APPROVING STIPULATION |
| COOPERATIVE, INC. FOR A TRANSMISSION |) | AND GRANTING A |
| UPGRADE TO THE SIOUX FALLS AREA 115 |) | TRANSMISSION UPGRADE |
| KV TRANSMISSION PROJECT |) | EL04-009 |

On February 27, 2004, East River Electric Power Cooperative, Inc. (East River) submitted to the Public Utilities Commission (Commission) an application for its proposed Sioux Falls Area 115 kilovolt (kV) transmission upgrade project. The application states that the proposed project would upgrade approximately 36 miles of an existing 69 kV transmission line and 7 existing 69 kV distribution substations to 115 kV to enable East River to continue to adequately and reliably serve the growing demand for electric service of its member distribution systems in the Sioux Falls area. The line and substation facilities to be upgraded are located in Lincoln and Minnehaha Counties, beginning at WAPA's Sioux Falls Substation on Rice Street and 478 Ave. (east of Great Bear), extending east to the West Brandon Substation on Holly Blvd. west of Brandon, then north and east to the Brandon and Corson Substations on Splitrock Blvd. on the north side of Brandon and east of Corson, respectively, then east on Redwood Blvd. and south on Chestnut Ave. to the Rowena Substation north of Rowena, then south and east to the Splitrock Substation on Highway 42 east of Sioux Falls, then south to the Harrisburg Substation west of Highway 11 (one mile south of the Harrisburg corner), then east to the Tea Substation two miles south of Tea. On March 19, 2004, Xcel Energy, Inc. (Xcel) filed a Motion to Intervene, which motion included a request to receive all filings in the docket.

On March 4, 2004, the Commission electronically transmitted notice of the filing and the intervention deadline of March 19, 2004, to interested individuals and entities. Applications for party status were due by April 27, 2004. On March 19, 2004, the Commission received a Motion to Intervene from Xcel Energy, Inc. (Xcel). By order dated April 19, 2004, the Commission granted intervention to Xcel. No applications for party status were filed.

On March 23, 2004, at its regularly scheduled meeting, the Commission, pursuant to SDCL 49-41B-12, unanimously voted to assess East River the minimum filing fee as requested by the Deputy Executive Director. On April 12, 2004, the Commission held a public input meeting.

On June 8, 2004, at a regularly scheduled meeting, Commission Staff notified the Commission that a Stipulation had been reached. The Stipulation set forth Findings of Fact, Conclusions of Law, and Terms and Conditions. The Commission approved the Stipulation with an effective date as of the date of the Order Approving the Stipulation. By adopting the Stipulation the Commission grants East River's application for a transmission upgrade, subject to the terms and conditions listed in the Stipulation.

The Commission has jurisdiction over this matter pursuant to SDCL Chapter 49-41B, specifically 49-41B-1, 49-41B-2, 49-41B-2.1, 49-41B-4, 49-41B-11, 49-41B-12, 49-41B-13, 49-41B-15, 49-41B-16, 49-41B-17, 49-41B-17.1, 49-41B-21, 49-41B-22, 49-41B-25, 49-41B-26, 49-41B-33, 49-41B-38, and ARSD Chapter 20:10:22. It is therefore

ORDERED, that the Stipulation entered into between East River, Commission Staff and Xcel on June 7, 2004, shall be approved and shall be incorporated by reference into this Decision and Order the same as if it had been set forth in its entirety herein; and it is

FURTHER ORDERED, that East River is granted approval to upgrade its transmission line, subject to the terms and conditions listed in the Stipulation.

Dated at Pierre, South Dakota, this 11th day of June, 2004.

CERTIFICATE OF SERVICE

The undersigned hereby certifies that this document has been served today upon all parties of record in this docket, as listed on the docket service list, by facsimile or by first class mail, in properly addressed envelopes, with charges prepaid thereon.

By: Delaine Kalbo

Date: 6/14/04

(OFFICIAL SEAL)

BY ORDER OF THE COMMISSION:

Robert K. Sahr
ROBERT K. SAHR, Chairman

Gary Hanson
GARY HANSON, Commissioner

James A. Burg
JAMES A. BURG, Commissioner

EL04-009



EAST RIVER

ELECTRIC POWER COOPERATIVE
121 Southeast First St. P.O. Box 227
Madison, SD 57042 Telephone (605) 256-4536

RECEIVED

JUL 20 2005

SOUTH DAKOTA PUBLIC
UTILITIES COMMISSION

July 14, 2005

Ms. Michele Farris, Utility Analyst
South Dakota Public Utilities Commission
500 East Capitol Avenue
Pierre, SD 57501-5070

RE: East River Electric's 115 kV Upgrade Project in the Sioux Falls Area

Dear Ms. Farris:

Enclosed is a list of landowners and tenants that we have used for East River's mailings on Part 1 of this project.

East River Electric is beginning this work now, as weather allows, and will complete Part 1 in 2005.

If you have any questions about this mailing or other aspect of the project, please let me know.

Sincerely,

Dan Wall, Manager
Transmission/Engineering Services

DW/jc

Enc.



EAST RIVER

ELECTRIC POWER COOPERATIVE

121 Southeast First St.
Madison, SD 57042

P.O. Box 227
Telephone (605) 256-4536

July 13, 2005

Ellis & Eastern Company
PO Box 84140
Sioux Falls, SD 57118-4140

Dear Landowner:

East River Electric Power Cooperative is in the process of upgrading its existing electric transmission system on the east and south side of Sioux Falls from 69,000 volts to 115,000 volts. The upgrade is necessary for East River Electric to reliably serve the increasing electric demand of its member distribution cooperatives in the rapidly growing Sioux Falls area.

We are notifying you of this transmission upgrade project as our records indicate that you own the following property on which some of the transmission lines to be upgraded are located:

C & NW RR NE1/4, Sec. 31-T102N-R48W, Minnehaha County, SD
C & NW RR NW1/4, Sec. 33-T102N-R48W, Minnehaha County, SD

The enclosed pamphlet provides information on East River Electric and its Sioux Falls area 115 kV transmission upgrade project. The pamphlet includes a map that shows the location of the transmission lines and substations to be upgraded. Also enclosed is a copy of the South Dakota Public Utilities Commission Order approving East River Electric's application for the transmission upgrade project. The back page of the pamphlet provides names and contact information for people at East River Electric that you can contact with any questions, comments, or concerns that you may have about the project as well as the contact information for the South Dakota Public Utilities Commission.

The property you own is located in Part 1 of this project. East River Electric is beginning this work now, as weather allows and will complete Part 1 in 2005. The upgrade to the transmission line will include replacing the existing electric conductors with larger sized ones and replacement of the top conductor with a similar conductor containing a fiber optic wire. The wooden poles supporting the electric line will be replaced with new wooden poles designed to carry the added weight of the larger conductor size. Several switches located within the existing line will be replaced as well.



If you lease or rent this property to others, we need to provide them with this information as well. Please contact Dan Wall, Manager of Transmission/Engineering Services at 888-256-4536 and provide him with the names and addresses of any renters/lessors you may have.

During construction, East River Electric personnel will work to minimize the impact to your property within the utility right of way. Any disturbance to the right of way as a result of this project will be corrected. Please contact Ron Golden, East River Electric's Land Agent at 888-256-4536 if you have any questions in this regard.

East River's electric facilities are designed and constructed according to national standards, however, safety precautions must still be observed and extra care should always be taken when working in the vicinity of an electric line. It is important that you are aware of all hazards and seek advice from an electric utility representative before attempting any of the following actions near an electric line:

- Installing buildings and/or equipment.
- Placing garbage, refuse or fallen timber under the line.
- Planting or cultivating trees or shrubs which when fully grown will grow to within 10 feet of the electric lines conductor.
- Excavating the ground within 15 feet of any transmission pole.
- Placing obstructions of any type within 15 feet of any transmission pole.
- Handling long/large items such as ladders.

If you have any questions, comments, or concerns about this project, either now or during construction, please contact either Ron Golden or Dan Wall at 888-256-4536.

Sincerely,



Jim Edwards *JE*
Assistant General Manager
Operations

JE/jc

Enc.

Mailing List for Part 1 - 115 kV Sioux Falls Upgrade Project

| First Name | Last Name | Address | Land Description | Section, Township, Range, County, State |
|------------------|------------------------------------|---|---|---|
| | Ellis & Eastern Company | PO Box 84140 Sioux Falls, SD 57118-4140 | C & NW RR NE1/4, Sec. 31-T102N-R48W, Minnehaha County, SD | C & NW RR NW1/4, Sec. 33-T102N-R48W, Minnehaha County, SD |
| | Xcel Energy % Manager Property Tax | 414 Nicollet Mall Minneapolis, MN 55401-1993 | NE1/4 (EX R-1 & RY & Ex E936.25' NE1/4 NE1/4 & Ex H-1) | Sec. 31-T102N-R48W, Minnehaha County, SD |
| | Brandon Bluffs, LLC | 5101 S Nevada Ave Sioux Falls, SD 57108 | Tract 1, Heartland Business Park Addition | Sec. 32-T102N-R48W, Minnehaha County, SD |
| James | Ode | 503 Sheffield Drive Richardson, TX 75081-5611 | W1/2 NE1/4 (Ex N277' S344' E234' & Ex Heartland Business Park Addition) & E1/2 NW1/4 (Ex RY & Ex Lot R-1) | Sec. 32-T102N-R48W, Minnehaha County, SD |
| | FFish LLC | 1008 Parkview Boulevard Brandon, SD 57005 | Lot 1, Block 2; Lot 3, Block 2 Heartland Business Park Addition | Sec. 32-T102N-R48W, Minnehaha County, SD |
| Burton | Ode | 1601 W Holly Boulevard Brandon, SD 57005 | N277' S344' E234' W1/2 NE1/4 | Sec. 32-T102N-R48W, Minnehaha County, SD |
| | Risty Family Limited Partnership | 121 S Main Avenue Brandon, SD 57005 | E1/2 NE1/4 Lying S of RR, Sec. 32-T102N-R48W, Minnehaha County, SD | Pt NW1/4 Lying S of RR ROW & W1/2 NE1/4 lying S of RR ROW, Sec. 33-T102N-R48W, Minnehaha County, SD |
| Alice | Nielsen | 115 N Sioux Boulevard Brandon, SD 57005 | SE1/4 NE1/4 (Ex RY & Ex Nielsen Addition & Ex H-1 & H-2) | Sec. 33-T102N-R48W, Minnehaha County, SD |
| Jerald & Cynthia | Schwebach | 108 S 5 th Avenue Brandon, SD 57005 | Tract 2 Nielsen Addition SE1/4 NE1/4 | Sec. 33-T102N-R48W, Minnehaha County, SD |
| | City of Brandon | PO Box 95 Brandon, SD 57005-0095 | Trs in SE1/4 SE1/4; 66' strip of RY Trs 1 & 2, Sec. 28-T102N-R48W, Minnehaha County, SD | W1/2 NE1/4 NE1/4, Sec. 33-T102N-R48W, Minnehaha County, SD |
| Edwin & Darlynn | Bartscher | 517 Crestview Circle Brandon, SD 57005 | Westview Estates Lot 12, Block 3, | Sec. 34-T102N-R48W, Minnehaha County, SD |
| Patrick & Lisa | Bolter | 520 Crestview Circle Brandon, SD 57005 | Westview Estates Lot 11, Block 3, | Sec. 34-T102N-R48W, Minnehaha County, SD |

| First Name | Last Name | Address | Land Description | Section, Township, Range, County, State |
|-------------------|-------------------------------------|---|---------------------------------|--|
| | Celebration United Methodist Church | PO Box 915 Brandon, SD 57005 | Tract 1 Tallgrass Addition | Sec. 34-T102N-R48W, Minnehaha County, SD |
| Patricia | Loosbrock | 613 Tamarac Avenue Brandon, SD 57005 | Traubs Addition Lot 1, Block 5 | Sec. 34-T102N-R48W, Minnehaha County, SD |
| Thomas & Tiffany | Grode | 612 Tamarac Brandon, SD 57005 | Traubs Addition Lot 19, Block 2 | Sec. 34-T102N-R48W, Minnehaha County, SD |
| Mark & Bonita | Meyer | 716 Magnolia Street Brandon, SD 57005 | Traubs Addition Lot 17, Block 2 | Sec. 34-T102N-R48W, Minnehaha County, SD |
| Roy & Phyllis | Swanson | 720 Magnolia Street Brandon, SD 57005 | Traubs Addition Lot 16, Block 2 | Sec. 34-T102N-R48W, Minnehaha County, SD |
| Gregory & Teresa | Koch | 800 Magnolia Street Brandon, SD 57005 | Traubs Addition Lot 15, Block 2 | Sec. 34-T102N-R48W, Minnehaha County, SD |
| Ryan & Erika | Feterl | 804 Magnolia Street Brandon, SD 57005 | Traubs Addition Lot 14, Block 2 | Sec. 34-T102N-R48W, Minnehaha County, SD |
| Steven & Teresa | Hansen | 808 Magnolia Street Brandon, SD 57005 | Traubs Addition Lot 13, Block 2 | Sec. 34-T102N-R48W, Minnehaha County, SD |
| | Ryan Thompson & Tandy Hieb | 812 Magnolia Street Brandon, SD 57005 | Traubs Addition Lot 12, Block 2 | Sec. 34-T102N-R48W, Minnehaha County, SD |
| David & Deborah | Johnston | 816 Magnolia Street Brandon, SD 57005 | Traubs Addition Lot 11, Block 2 | Sec. 34-T102N-R48W, Minnehaha County, SD |
| Marc & Kelly | Eichelberg | 820 Magnolia Street Brandon, SD 57005 | Traubs Addition Lot 10 Block 2 | Sec. 34-T102N-R48W, Minnehaha County, SD |
| Scot & Karli | Pulse | 900 Magnolia Street Brandon, SD 57005 | Traubs Addition Lot 9, Block 2 | Sec. 34-T102N-R48W, Minnehaha County, SD |
| James & Kimberly | Raley | 904 Magnolia Street Brandon, SD 57005 | Traubs Addition Lot 8, Block 2 | Sec. 34-T102N-R48W, Minnehaha County, SD |
| Nathan | Myers | 908 Magnolia Street Brandon, SD 57005 | Traubs Addition Lot 7, Block 2 | Sec. 34-T102N-R48W, Minnehaha County, SD |
| Mark | Johnson | 912 Magnolia Street Brandon, SD 57005 | Traubs Addition Lot 6, Block 2 | Sec. 34-T102N-R48W, Minnehaha County, SD |
| Anthony & Laurie | Kuck | 916 Magnolia Street Brandon, SD 57005 | Traubs Addition Lot 5, Block 2 | Sec. 34-T102N-R48W, Minnehaha County, SD |
| Alan & Susan | Cavanaugh | 1000 Magnolia Street Brandon, SD 57005 | Traubs Addition Lot 4, Block 2 | Sec. 34-T102N-R48W, Minnehaha County, SD |
| William & Shirley | Amundson | 1004 Magnolia Street Brandon, SD 57005 | Traubs Addition Lot 3, Block 2 | Sec. 34-T102N-R48W, Minnehaha County, SD |
| Douglas | Severson | 1008 Magnolia Street Brandon, SD 57005 | Traubs Addition Lot 2, Block 2 | Sec. 34-T102N-R48W, Minnehaha County, SD |